

Features

- ✧ Silicon zener diodes
- ✧ Low profile surface-mount package
- ✧ Zener and surge current specification
- ✧ Low leakage current
- ✧ Excellent stability
- ✧ High temperature soldering guaranteed:
260°C / 10 seconds
- ✧ Green compound with suffix "G" on packing code & prefix "G" on datecode
- ✧ Meet MSL level 1, per J-STD-020D, lead free maximum peak of 260°C

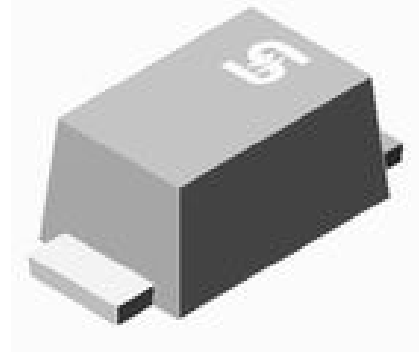

Mechanical Data

- ✧ Case: Sub SMA Plastic
- ✧ Terminals: Pure tin plated, lead free
- ✧ Packaging method: refer to package code
- ✧ Marking code: as table
- ✧ Weight: 0.0196 gram

Ordering Information (example)

Part No.	Package	Packing	Packing code	Green Compound Packing code
BZD27C6V8P	Sub-SMA	3K / 7" REEL	RV	RVG

Maximum Ratings and Electrical Characteristics

Rating at 25 °C ambient temperature unless otherwise specified.

Type Number	Symbol	Value	Unit
Forward Voltage @ $I_F=0.2A$	V_F	1.2	Volts
Power Dissipation at $T_L=80^\circ C$ $T_A=25^\circ C$ (Note 1)	P_{tot}	2.3 1.0	Watts
Non-Repetitive Peak Pulse Power Dissipation 100us square pulse (Note 2)	P_{ZSM}	300	Watts
Non-Repetitive Peak Pulse Power Dissipation 10/1000us waveform (BZD27C6V8P to BZD27C100P) (Note 2)	P_{RSM}	150	Watts
Non-Repetitive Peak Pulse Power Dissipation 10/1000us waveform (BZD27C110P to BZD27C220P) (Note 2)	P_{RSM}	100	Watts
Thermal Resistance Junction to Ambient Air (Note 1)	$R_{\theta JA}$	180	$^\circ C/W$
Thermal Resistance Junction to Lead	$R_{\theta JL}$	30	$^\circ C/W$
Operating and Storage Temperature Range	T_J, T_{STG}	-65 to +175	$^\circ C$

Note 1: Mounted on Cu-Pad size 5mm x 5mm ($\geq 40\mu m$ thick)

Note 2: $T_J=25^\circ C$ Prior to Surge

RATINGS AND CHARACTERISTIC CURVES (BZD27C SERIES)

FIG. 1 TYPICAL FORWARD CHARACTERISTICS

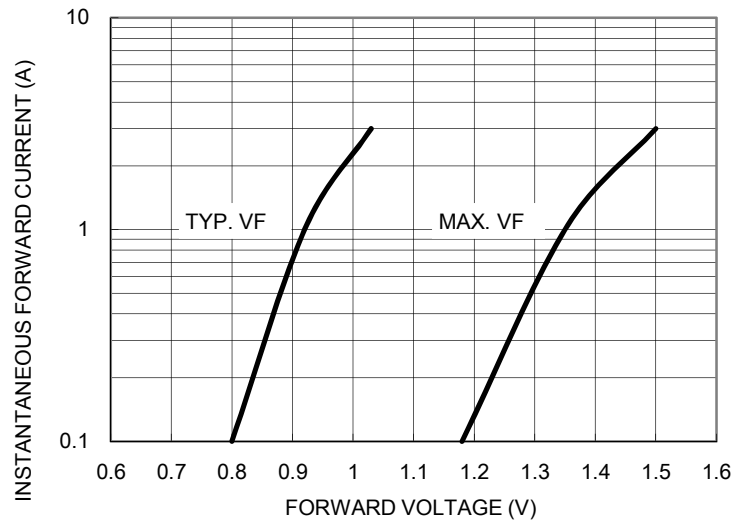

FIG. 2 TYP. DIODE CAPACITANCE vs REVERSE VOLTAGE

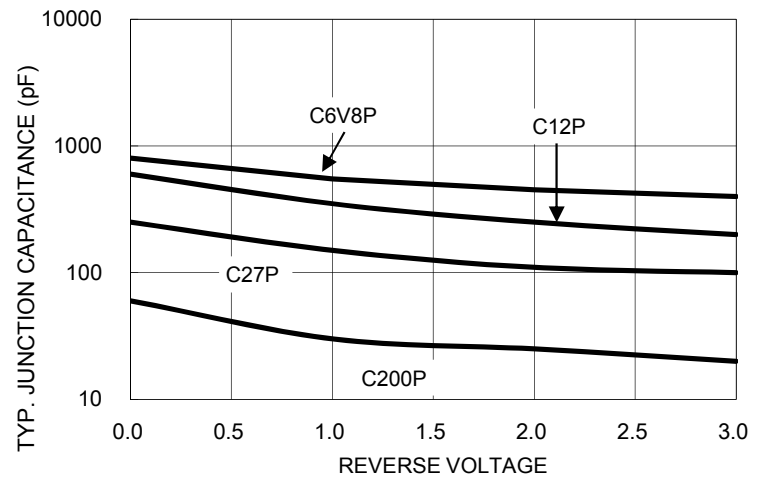

FIG. 3 POWER DISSIPATION vs AMBIENT TEMPERATURE

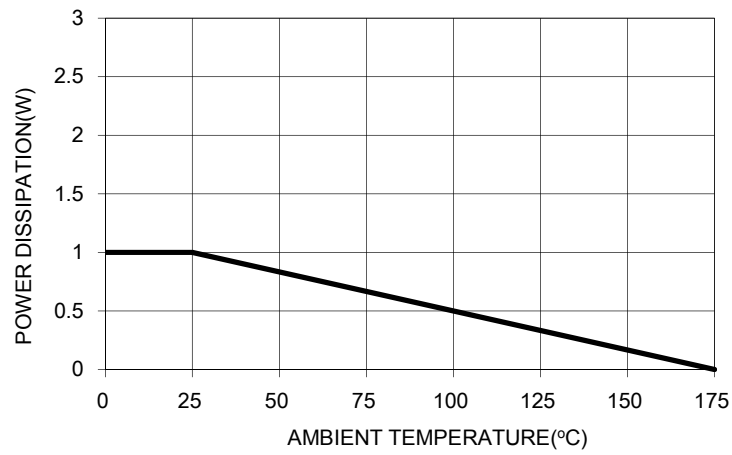
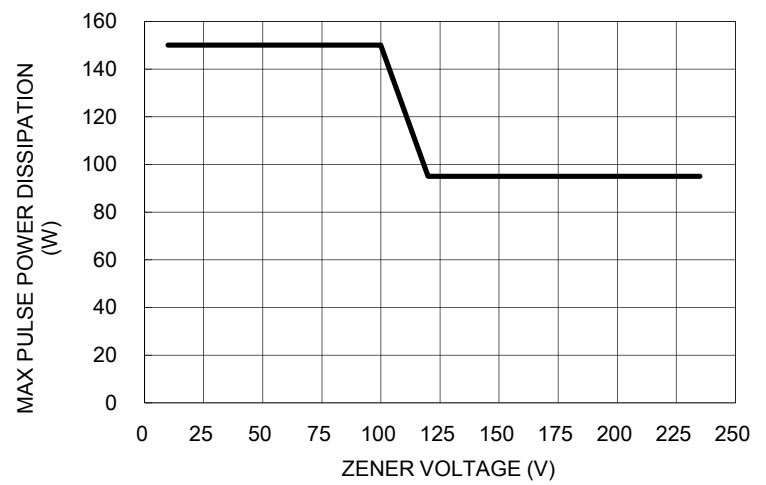

FIG. 4 MAXIMUM PULSE POWER DISSIPATION vs ZENER VOLTAGE



ELECTRICAL CHARACTERISTICS (TA=25°C unless otherwise noted)

Device	Device Marking Code	Working Voltage (Note 1)		Differential Resistance		Temperature Coefficient		Test Current	Reverse Current@ Reverse Voltage	
		V _Z @ I _{ZT}		r _{dif} @ I _Z		ALPH _Z @ I _Z		I _{ZT}	I _R	V _R
		V		Ω		% / °C		mA	uA	V
		Min.	Max	typ	Max.	Min.	Max		Max.	
BZD27C6V8P	D7	6.4	7.2	1	3	0	0.07	100	10	3
BZD27C7V5P	D8	7.0	7.9	1	2	0	0.07	100	50	3
BZD27C8V2P	D9	7.7	8.7	1	2	0.03	0.08	100	10	3
BZD27C9V1P	E0	8.5	9.6	2	4	0.03	0.08	50	10	5
BZD27C11P	E2	10.4	11.6	4	7	0.05	0.10	50	4	8.2
BZD27C12P	E3	11.4	12.7	4	7	0.05	0.10	50	3	9.1
BZD27C13P	E4	12.4	14.1	5	10	0.05	0.10	50	2	10
BZD27C15P	E5	13.8	15.6	5	10	0.05	0.10	25	1	11
BZD27C16P	E6	15.3	17.1	6	15	0.06	0.11	25	1	12
BZD27C18P	E7	16.8	19.1	6	15	0.06	0.11	25	1	13
BZD27C24P	F0	22.8	25.6	7	15	0.06	0.11	25	1	18
BZD27C27P	F1	25.1	28.9	7	15	0.06	0.11	25	1	20
BZD27C30P	F2	28	32	8	15	0.06	0.11	25	1	22
BZD27C33P	F3	31	35	8	15	0.06	0.11	25	1	24
BZD27C36P	F4	34	38	21	40	0.06	0.11	10	1	27
BZD27C39P	F5	37	41	21	40	0.06	0.11	10	1	30
BZD27C43P	F6	40	46	24	45	0.07	0.12	10	1	33
BZD27C47P	F7	44	50	24	45	0.07	0.12	10	1	36
BZD27C51P	F8	48	54	25	60	0.07	0.12	10	1	39
BZD27C62P	G0	58	66	25	80	0.08	0.13	10	1	47
BZD27C68P	G1	64	72	25	80	0.08	0.13	10	1	51
BZD27C75P	G2	70	79	30	100	0.08	0.13	10	1	56
BZD27C100P	G5	94	106	60	200	0.09	0.13	4	1	75
BZD27C120P	G7	114	127	150	300	0.09	0.13	4	1	91
BZD27C180P	H1	168	191	280	450	0.09	0.13	4	1	130
BZD27C200P	H2	188	212	350	750	0.09	0.13	4	1	150
BZD27C220P	H3	208	233	430	900	0.09	0.13	4	1	160

Notes: 1. Pulse test: tp ≤ 5ms.

ELECTRICAL CHARACTERISTICS (TA=25°C unless otherwise noted)

Device	Rev. Breakdown Voltage	Test Current	Temperature Coefficient		Clamping Voltage		Reverse Current@ Stand-Off Voltage	
	$V_{(BR)}@I_{test}$	I_{test}	ALPHz@ I_{test}		Vc	@ I_{RSM} (Note 1)	I_R	@ V_{WM}
	V	mA	%/ $^{\circ}C$		V	A	μA	V
	Min.		Min.	Max	Max.		Max.	
BZD27C7V5P	7	100	0	0.07	11.3	13.3	1500	6.2
BZD27C8V2P	7.7	100	0.03	0.08	12.3	12.2	1200	6.8
BZD27C9V1P	8.5	50	0.03	0.08	13.3	11.3	100	7.5
BZD27C11P	10.4	50	0.05	0.10	15.7	9.6	5	9.1
BZD27C12P	11.4	50	0.05	0.10	17	8.8	5	10
BZD27C13P	12.4	50	0.05	0.10	18.9	7.9	5	11
BZD27C15P	13.8	50	0.05	0.10	20.9	7.2	5	12
BZD27C16P	15.3	25	0.06	0.11	22.9	6.6	5	13
BZD27C18P	16.8	25	0.06	0.11	25.6	5.9	5	15
BZD27C24P	22.8	25	0.06	0.11	33.8	4.4	5	20
BZD27C27P	25.1	25	0.06	0.11	38.1	3.9	5	22
BZD27C30P	28	25	0.06	0.11	42.2	3.6	5	24
BZD27C33P	31	25	0.06	0.11	46.2	3.2	5	27
BZD27C36P	34	10	0.06	0.11	50.1	3	5	30
BZD27C39P	37	10	0.06	0.11	54.1	2.8	5	33
BZD27C43P	40	10	0.07	0.12	60.7	2.5	5	36
BZD27C47P	44	10	0.07	0.12	65.5	2.3	5	39
BZD27C51P	48	10	0.07	0.12	70.8	2.1	5	43
BZD27C62P	58	10	0.08	0.13	86.5	1.7	5	51
BZD27C68P	64	10	0.08	0.13	94.4	1.6	5	56
BZD27C75P	70	10	0.08	0.13	103.5	1.5	5	62
BZD27C100P	94	5	0.09	0.13	139	1.1	5	82
BZD27C120P	114	5	0.09	0.13	152	0.65	5	100
BZD27C180P	168	5	0.09	0.13	229	0.43	5	150
BZD27C200P	188	5	0.09	0.13	254	0.39	5	160
BZD27C220P	208	5	0.09	0.13	279	0.35	5	176

Notes: 1. Non-repetitive peak reverse current in accordance with "IEC 60-1, Section 8" (10/1000 us pulse)

Ordering information

Part No.	Package	Packing	Tape Size	Packing code	Green Compound Packing code
BZD27CxxxP (Note)	Sub-SMA	1.8K / 7" REEL	8mm	RU	RUG
	Sub-SMA	3K / 7" REEL	8mm	RV	RVG
	Sub-SMA	7.5K / 13" REEL	8mm	RT	RTG
	Sub-SMA	10K / 13" REEL	8mm	RQ	RQG
	Sub-SMA	1.8K / 7" REEL	12mm	R3	R3G
	Sub-SMA	3K / 7" REEL	12mm	RF	RFG
	Sub-SMA	7.5K / 13" REEL	12mm	R2	R2G
	Sub-SMA	10K / 13" REEL	12mm	RH	RHG

Note: "xxx" is Device Code from "6V8" thru "220".

Tape & Reel specification

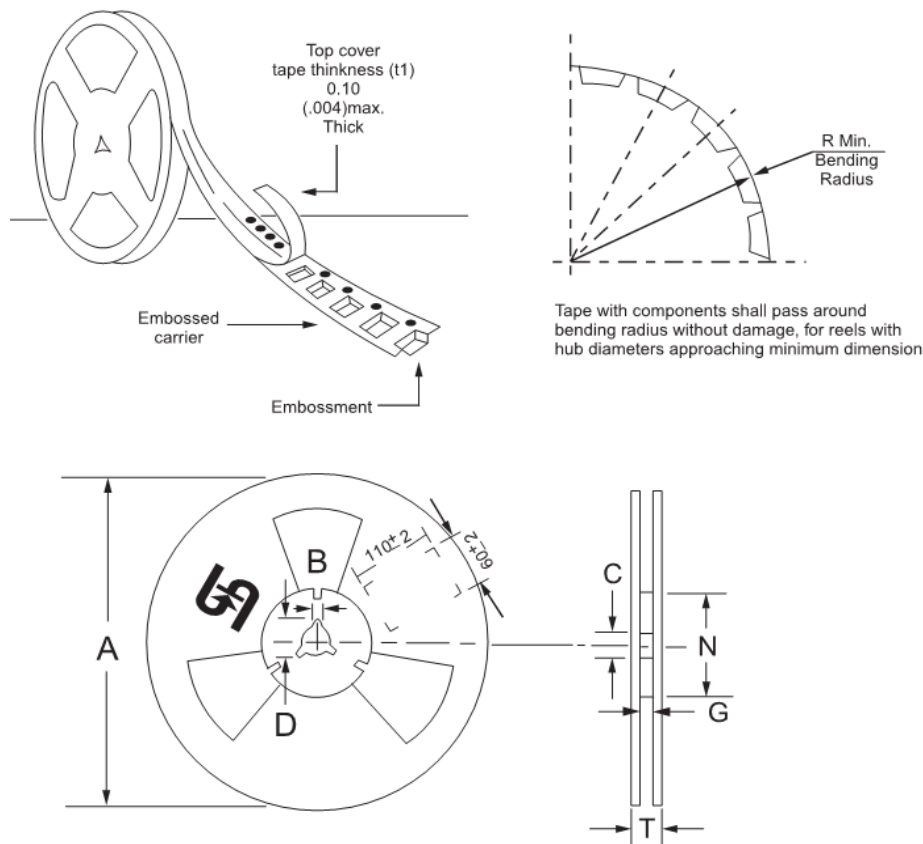

Reel Size	Tape Size	A	B	C	D	N	G	T
		±2.0	±0.4	+0.5;-0.2	min	±1.0	+0.8;-0	max
7"	8mm	178	1.9	13	21	62	8.2	10.6
	12mm						12.2	14.6
Reel Size	Tape Size	A	B	C	D	N	G	T
		max	±0.5	±0.5	min	±0.5	+2.0;-0	max
13"	8mm	330	2	13	20.2	75	8.5	14.5
	12mm						12.4	18.4

Unit (mm)

Suggested PAD Layout

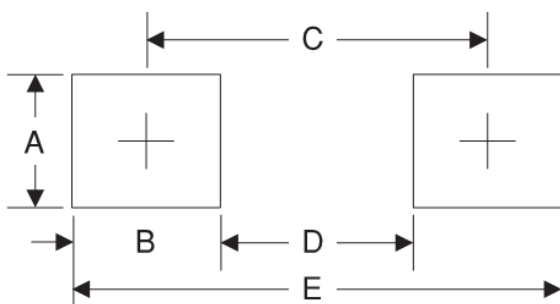

Symbol	Unit(mm)
A	1.4
B	1.2
C	3.1
D	1.9
E	4.3

Package Outline Dimensions

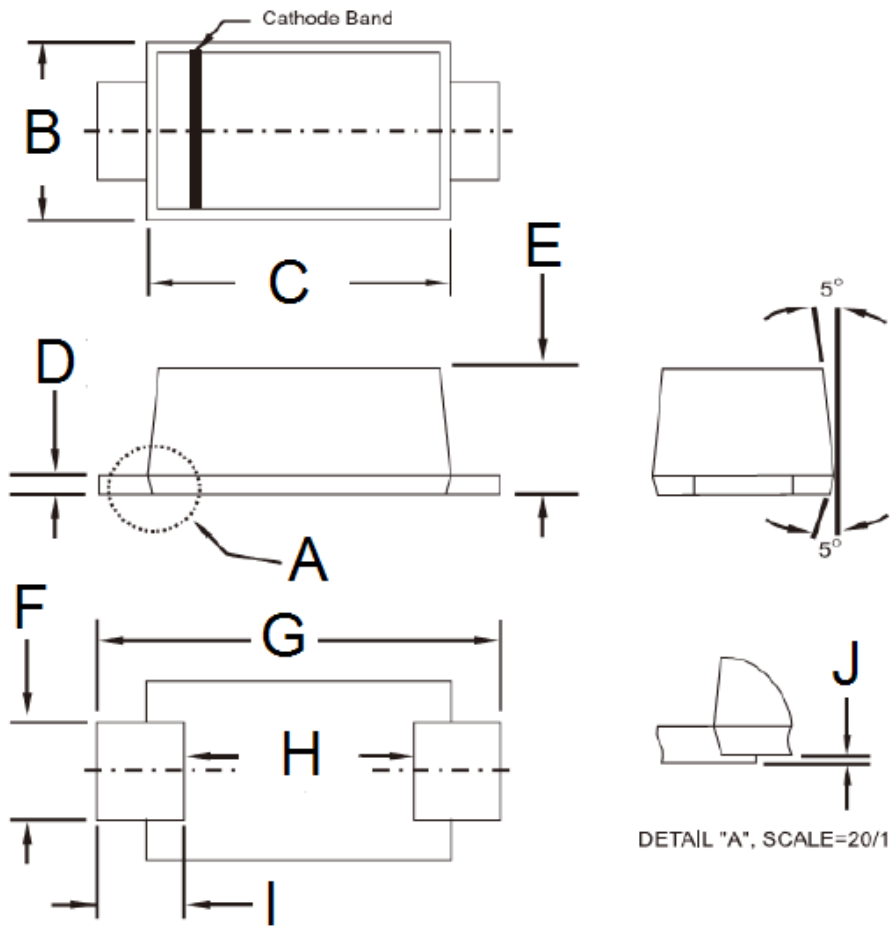

DIM.	Unit(mm)		Unit(inch)	
	Min	Max	Min	Max
B	1.70	1.90	0.067	0.075
C	2.70	2.90	0.106	0.114
D	0.16	0.30	0.006	0.012
E	1.23	1.43	0.048	0.056
F	0.80	1.20	0.031	0.047
G	3.40	3.80	0.134	0.150
H	2.45	2.60	0.096	0.102
I	0.35	0.85	0.014	0.033
J	0.00	0.10	0.000	0.004

Marking Diagram

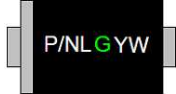

P/NL = Specific Device Code
G = Green Compound
YW = Date Code