

P4KE SERIES

400 Watts Transient Voltage Suppressor

DO-41

Features

- ✧ UL Recognized File # E-326243
- ✧ Qualified as per AEC-Q101
- ✧ Plastic package has Underwriters Laboratory Flammability Classification 94V-0
- ✧ 400 watts surge capability with a 10 / 1000 us waveform
- ✧ Excellent clamping capability
- ✧ Low Dynamic impedance
- ✧ Fast response time: Typically less than 1.0ps from 0 volt to VBR for unidirectional and 5.0ns for bidirectional
- ✧ Typical I_R less than 1uA above 10V
- ✧ High temperature soldering guaranteed: 260°C / 10 seconds / .375", (9.5mm) lead length / 5lbs., (2.3kg) tension
- ✧ Green compound with suffix "G" on packing code & prefix "G" on datecode

Mechanical Data

- ✧ Case: Molded plastic
- ✧ Lead: Pure tin plated lead free, solderable per MIL-STD-202, Method 208
- ✧ Polarity: Color band denotes cathode except bipolar
- ✧ Weight: 0.3 gram

Maximum Ratings and Electrical Characteristics

Rating at 25 °C ambient temperature unless otherwise specified.
 Single phase, half wave, 60 Hz, resistive or inductive load.
 For capacitive load, derate current by 20%

Type Number	Symbol	Value	Unit
Peak Power Dissipation at $T_A=25^\circ\text{C}$, $T_p=1\text{ms}$ (Note 1)	P_{PK}	Minimum 400	Watts
Steady State Power Dissipation at $T_L=75^\circ\text{C}$ Lead Lengths .375", 9.5mm (Note 2)	P_D	1	Watts
Peak Forward Surge Current, 8.3ms Single Half Sine-wave Superimposed on Rated Load (JEDEC method)(Note 3)	I_{FSM}	40	Amps
Maximum Instantaneous Forward Voltage at 25.0A for Unidirectional Only (Note 4)	V_F	3.5 / 6.5	Volts
Operating and Storage Temperature Range	T_J, T_{STG}	-55 to +175	°C

Note 1: Non-repetitive Current Pulse Per Fig. 3 and Derated above $T_A=25^\circ\text{C}$ Per Fig. 2

Note 2: Mounted on 5 x 5 mm Copper Pads to Each Terminal

Note 3: 8.3ms Single Half Sine-wave or Equivalent Square Wave, Duty Cycle=4 Pulses Per Minute Maximum

Note 4: $V_F=3.5\text{V}$ for Devices of $V_{BR} \leq 200\text{V}$ and $V_F=6.5\text{V}$ Max. for Device $V_{BR} > 200\text{V}$

Devices for Bipolar Applications

1. For Bidirectional Use C or CA Suffix for Types P4KE6.8 through Types P4KE440
2. Electrical Characteristics Apply in Both Directions

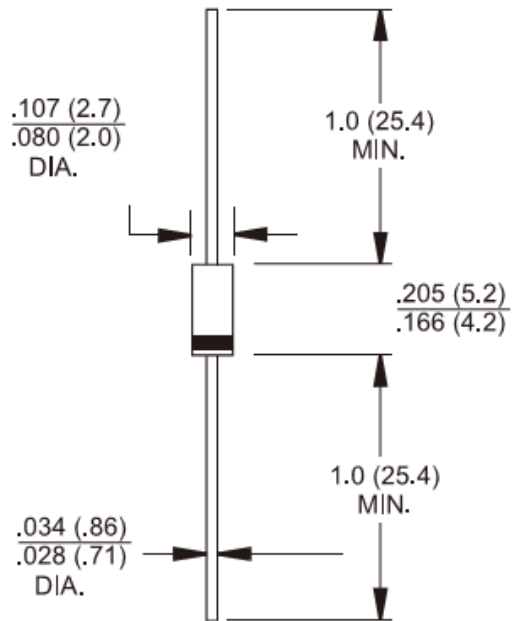

Dimensions in inches and (millimeters)

Marking Diagram



- P4KEXX = Specific Device Code
- G = Green Compound
- Y = Year
- M = Work Month

RATINGS AND CHARACTERISTIC CURVES (P4KE SERIES)

FIG. 1 PEAK PULSE POWER RATING CURVE

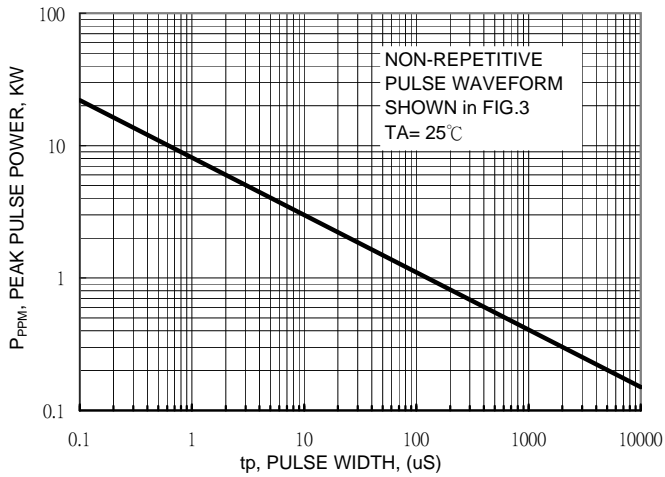

FIG.2 STEADY STATE POWER DERATING CURVE

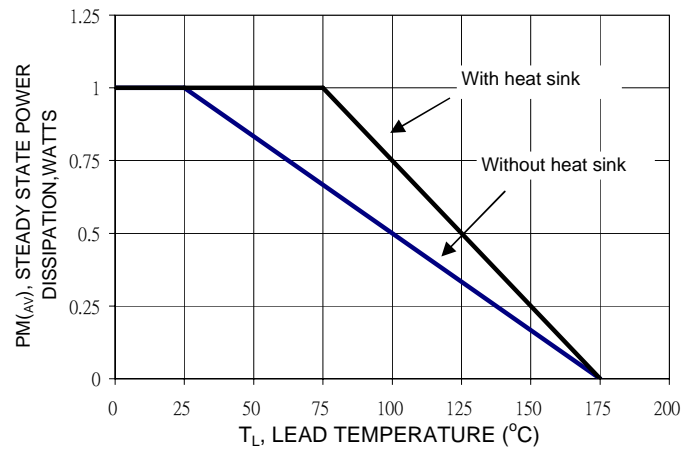

FIG. 3 CLAMPING POWER PULSE WAVEFORM

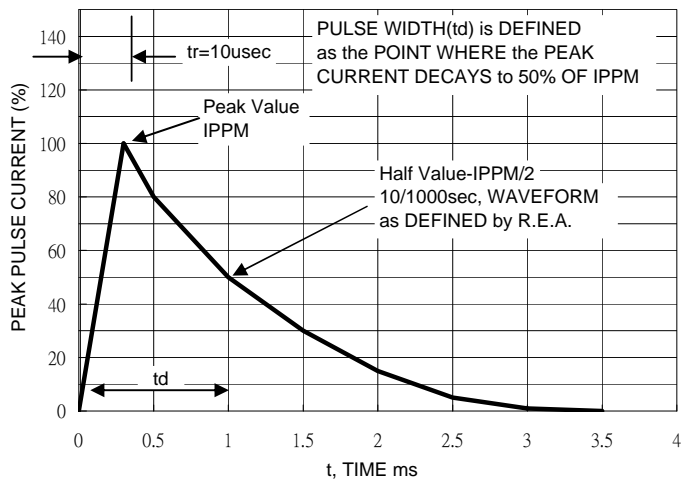

FIG. 4 MAXIMUM NON-REPETITIVE FORWARD SURGE CURRENT UNIDIRECTIONAL ONLY

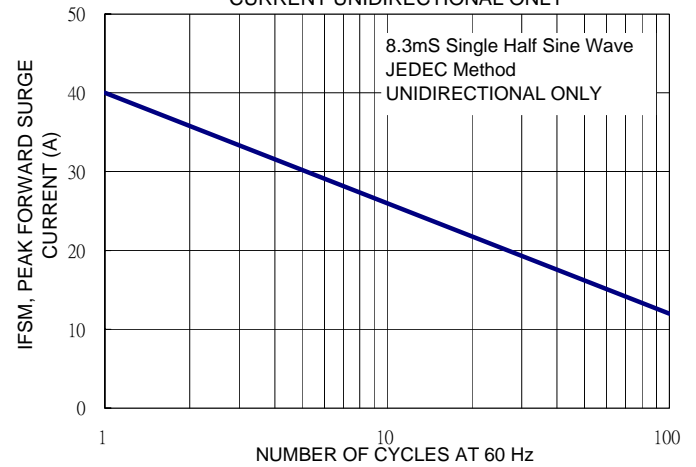
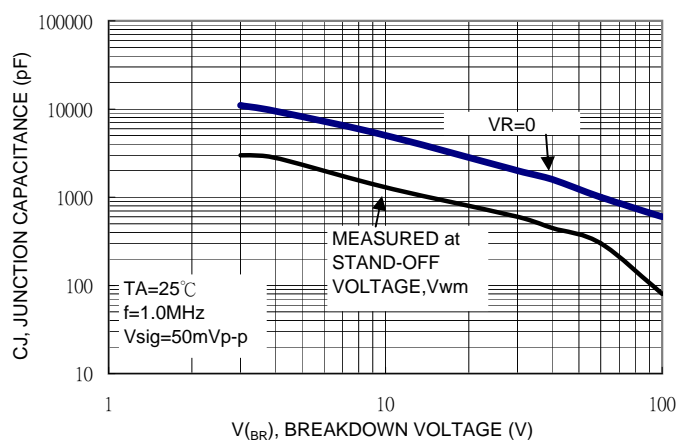

FIG. 5 TYPICAL JUNCTION CAPACITANCE



ELECTRICAL CHARACTERISTICS (TA=25°C unless otherwise noted)

General Part Number	Nominal Voltage	Breakdown Voltage (Note 1)		Test Current	Stand-Off Voltage	Maximum Reverse Leakage @ V _{WM}	Maximum Peak Pulse Current	Maximum Clamping Voltage @ IPPM	Maximum Temperature Coefficient
	(V)	V _{BR}		I _T	V _{WM}	ID	I _{PPM}	V _c	of VBR
		(V)	(V)	(mA)	(V)	(uA)	(A)	(V)	(%/°C)
		Min	Max				(Note 2)		
P4KE6.8	6.8	6.12	7.48	10	5.50	1000	38.0	10.8	0.057
P4KE6.8A	6.8	6.46	7.14	10	5.80	1000	40.0	10.5	0.057
P4KE7.5	7.5	6.75	8.25	10	6.05	500	35.0	11.7	0.061
P4KE7.5A	7.5	7.13	7.88	10	6.40	500	37.0	11.3	0.061
P4KE8.2	8.2	7.38	9.02	10	6.63	200	33.0	12.5	0.065
P4KE8.2A	8.2	7.79	8.61	10	7.02	200	34.0	12.1	0.065
P4KE9.1	9.1	8.19	10.00	1	7.37	50	30.0	13.8	0.068
P4KE9.1A	9.1	8.65	9.55	1	7.78	50	31.0	13.4	0.068
P4KE10	10	9.00	11.00	1	8.10	10	28.0	15.0	0.073
P4KE10A	10	9.50	10.5	1	8.55	10	29.0	14.5	0.073
P4KE11	11	9.90	12.1	1	8.92	1	26.0	16.2	0.075
P4KE11A	11	10.5	11.6	1	9.40	1	27.0	15.6	0.075
P4KE12	12	10.8	13.2	1	9.72	1	24.0	17.3	0.078
P4KE12A	12	11.4	12.6	1	10.2	1	25.0	16.7	0.078
P4KE13	13	11.7	14.3	1	10.5	1	22.0	19.0	0.081
P4KE13A	13	12.4	13.7	1	11.1	1	23.0	18.2	0.081
P4KE15	15	13.5	16.5	1	12.1	1	19.0	22.0	0.084
P4KE15A	15	14.3	15.8	1	12.8	1	20.0	21.2	0.084
P4KE16	16	14.4	17.6	1	12.9	1	17.8	23.5	0.086
P4KE16A	16	15.2	16.8	1	13.6	1	18.6	22.5	0.086
P4KE18	18	16.2	19.8	1	14.5	1	16.0	26.5	0.088
P4KE18A	18	17.1	18.9	1	15.3	1	16.5	25.5	0.088
P4KE20	20	18.0	22.0	1	16.2	1	14.0	29.1	0.090
P4KE20A	20	19.0	21.0	1	17.1	1	15.0	27.7	0.090
P4KE22	22	19.8	24.2	1	17.8	1	13.0	31.9	0.092
P4KE22A	22	20.9	23.1	1	18.8	1	13.7	30.6	0.092
P4KE24	24	21.6	26.4	1	19.4	1	12.0	34.7	0.094
P4KE24A	24	22.8	25.2	1	20.5	1	12.6	33.2	0.094
P4KE27	27	24.3	29.7	1	21.8	1	10.7	39.1	0.096
P4KE27A	27	25.7	28.4	1	23.1	1	11.0	37.5	0.096
P4KE30	30	27.0	33.0	1	24.3	1	9.6	43.5	0.097
P4KE30A	30	28.5	31.5	1	25.6	1	10.0	41.4	0.097
P4KE33	33	29.7	36.3	1	26.8	1	8.8	47.7	0.098
P4KE33A	33	31.4	34.7	1	28.2	1	9.0	45.7	0.098
P4KE36	36	32.4	39.6	1	29.1	1	8.0	52.0	0.099
P4KE36A	36	34.2	37.8	1	30.8	1	8.4	49.9	0.099
P4KE39	39	35.1	42.9	1	31.6	1	7.4	56.4	0.100
P4KE39A	39	37.1	41.0	1	33.3	1	7.7	53.9	0.100
P4KE43	43	38.7	47.3	1	34.8	1	6.7	61.9	0.101
P4KE43A	43	40.9	45.2	1	36.8	1	7.0	59.3	0.101
P4KE47	47	42.3	51.7	1	38.1	1	6.2	67.8	0.101
P4KE47A	47	44.7	49.4	1	40.2	1	6.4	64.8	0.101
P4KE51	51	45.9	56.1	1	41.3	1	5.7	73.5	0.102
P4KE51A	51	48.5	53.6	1	43.6	1	6.0	70.1	0.102
P4KE56	56	50.4	61.6	1	45.4	1	5.2	80.5	0.103
P4KE56A	56	53.2	58.8	1	47.8	1	5.4	77.0	0.103
P4KE62	62	55.8	68.2	1	50.2	1	4.7	89.0	0.104
P4KE62A	62	58.9	65.1	1	53.0	1	5.0	85.0	0.104
P4KE68	68	61.2	74.8	1	55.1	1	4.2	98.0	0.104
P4KE68A	68	64.6	71.4	1	58.1	1	4.5	92.0	0.104
P4KE75	75	67.5	82.5	1	60.7	1	3.8	108	0.105
P4KE75A	75	71.3	78.8	1	64.1	1	4.0	103	0.105
P4KE82	82	73.8	90.2	1	66.4	1	3.5	118	0.105
P4KE82A	82	77.9	86.1	1	70.1	1	3.7	113	0.105
P4KE91	91	81.9	100	1	73.7	1	3.2	131	0.106
P4KE91A	91	86.5	95.5	1	77.8	1	3.3	125	0.106

ELECTRICAL CHARACTERISTICS (TA=25°C unless otherwise noted)

General Part Number	Nominal Voltage	Breakdown Voltage (Note 1)		Test Current	Stand-Off Voltage	Maximum Reverse Leakage @ V _{WM}	Maximum Peak Pulse Current	Maximum Clamping Voltage @ IPPM	Maximum Temperature Coefficient
	(V)	V _{BR}		I _T	V _{WM}	I _D	I _{PPM}	V _c	of VBR
		(V)	(V)	(mA)	(V)	(uA)	(A)	(V)	(%/°C)
		Min	Max				(Note 2)		
P4KE100	100	90	110	1	81.0	1	2.9	144	0.106
P4KE100A	100	95	105	1	85.5	1	3.0	137	0.106
P4KE110	110	99	121	1	89.2	1	2.6	158	0.107
P4KE110A	110	105	116	1	94.0	1	2.7	152	0.107
P4KE120	120	108	132	1	97.2	1	2.4	173	0.107
P4KE120A	120	114	126	1	102	1	2.5	165	0.107
P4KE130	130	117	143	1	105	1	2.2	187	0.107
P4KE130A	130	124	137	1	111	1	2.3	179	0.107
P4KE150	150	135	165	1	121	1	1.9	215	0.108
P4KE150A	150	143	158	1	128	1	2.0	207	0.108
P4KE160	160	144	176	1	130	1	1.8	230	0.108
P4KE160A	160	152	168	1	136	1	1.9	219	0.108
P4KE170	170	153	187	1	138	1	1.7	244	0.108
P4KE170A	170	162	179	1	145	1	1.8	234	0.108
P4KE180	180	162	198	1	146	1	1.6	258	0.108
P4KE180A	180	171	189	1	154	1	1.7	246	0.108
P4KE200	200	180	220	1	162	1	1.4	287	0.108
P4KE200A	200	190	210	1	171	1	1.51	274	0.108
P4KE220	220	198	242	1	175	1	1.20	344	0.108
P4KE220A	220	209	231	1	185	1	1.30	328	0.108
P4KE250	250	225	275	1	202	1	1.10	360	0.110
P4KE250A	250	237	263	1	214	1	1.20	344	0.110
P4KE300	300	270	330	1	243	1	0.97	430	0.110
P4KE300A	300	285	315	1	256	1	1.00	414	0.110
P4KE350	350	315	385	1	284	1	0.83	504	0.110
P4KE350A	350	332	368	1	300	1	0.87	482	0.110
P4KE400	400	360	440	1	324	1	0.73	574	0.110
P4KE400A	400	380	420	1	342	1	0.76	548	0.110
P4KE440	440	396	484	1	356	1	0.66	631	0.110
P4KE440A	440	418	462.0	1	376	1	0.69	600	0.110

Notes:

1. V_{BR} measure after I_T applied for 300us, I_T=square wave pulse or equivalent.
2. Surge current waveform per Figure. 3 and derate per Figure. 2.
3. For bipolar types having V_{WM} of 10 volts and under, the I_D limit is doubled.
4. All terms and symbols are consistent with ANSI/IEEE C62.35.