

## D<sup>2</sup>PAK



### Features

- ✧ UL Recognized File # E-326854
- ✧ For surface mounted application
- ✧ Plastic material used carriers Underwriters Laboratory Classification 94V-0
- ✧ Metal silicon junction, majority carrier conduction
- ✧ Low power loss, high efficiency
- ✧ High current capability, low forward voltage drop
- ✧ High surge capability
- ✧ For use in low voltage, high frequency inverters, free wheeling, and polarity protection applications
- ✧ Guard-ring for overvoltage protection
- ✧ High temperature soldering guaranteed: 260°C/10 seconds, at terminals
- ✧ Green compound with suffix "G" on packing code & prefix "G" on datecode
- ✧ Qualified as per AEC-Q101

### Mechanical Data

- ✧ Case: JEDEC D<sup>2</sup>PAK molded plastic
- ✧ Terminals: Pure tin plated, lead free, solderable per MIL-STD-750, Method 2026
- ✧ Polarity: As marked
- ✧ Mounting position: Any
- ✧ Mounting torque: 5 in. - lbs, max
- ✧ Weight: 1.7 grams

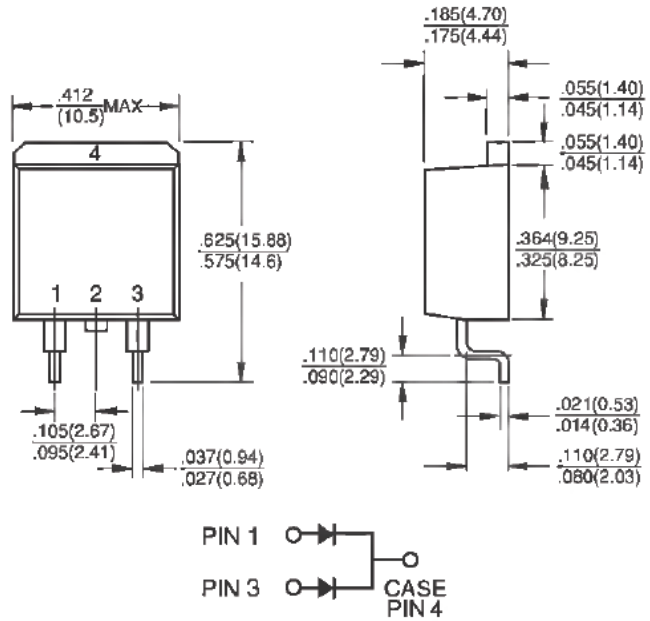

### Dimensions in inches and (millimeters)

#### Marking Diagram



- MBRS20XXCT = Specific Device Code
- G = Green Compound
- Y = Year
- WW = Work Week

### Maximum Ratings and Electrical Characteristics

Rating at 25 °C ambient temperature unless otherwise specified.  
Single phase, half wave, 60 Hz, resistive or inductive load.  
For capacitive load, derate current by 20%

Type Number	Symbol	MBRS 2035 CT	MBRS 2045 CT	MBRS 2050 CT	MBRS 2060 CT	MBRS 2090 CT	MBRS 20100 CT	MBRS 20150 CT	Unit
Maximum Repetitive Peak Reverse Voltage	V <sub>RRM</sub>	35	45	50	60	90	100	150	V
Maximum RMS Voltage	V <sub>RMS</sub>	24	31	35	42	63	70	105	V
Maximum DC Blocking Voltage	V <sub>DC</sub>	35	45	50	60	90	100	150	V
Maximum Average Forward Rectified Current at T <sub>c</sub> =135 °C	I <sub>F(AV)</sub>	20							A
Peak Repetitive Forward Current (Rated VR, Square Wave, 20KHz) at T <sub>c</sub> =135 °C	I <sub>FRM</sub>	20							A
Peak Forward Surge Current, 8.3 ms Single Half Sine-wave Superimposed on Rated Load (JEDEC method)	I <sub>FSM</sub>	150							A
Peak Repetitive Reverse Surge Current (Note 1)	I <sub>RRM</sub>	1	0.5					A	
Maximum Instantaneous Forward Voltage (Note 2) IF=10A, T <sub>A</sub> =25 °C IF=10A, T <sub>A</sub> =125 °C IF=20A, T <sub>A</sub> =25 °C IF=20A, T <sub>A</sub> =125 °C	V <sub>F</sub>	-	0.57	0.80	0.70	0.85	0.75	0.99	V
Maximum Reverse Current @ Rated VR T <sub>A</sub> =25 °C T <sub>A</sub> =125 °C	I <sub>R</sub>	15	10	5					mA
Voltage Rate of Change (Rated V <sub>R</sub> )	dV/dt	10000							V/us
Typical Thermal Resistance	R <sub>θJC</sub>	1.5				2			°C/W
Operating Temperature Range	T <sub>J</sub>	- 65 to + 150							°C
Storage Temperature Range	T <sub>STG</sub>	- 65 to + 175							°C

Note 1: 2.0uS Pulse Width, f=1.0KHz

Note 2: Pulse Test : 300uS Pulse Width, 1% Duty Cycle

## RATINGS AND CHARACTERISTIC CURVES (MBRS2035CT THRU MBRS20150CT)

FIG.1 FORWARD CURRENT DERATING CURVE

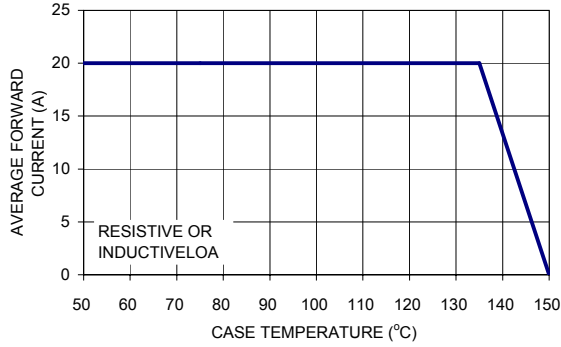

FIG. 2 MAXIMUM NON-REPETITIVE FORWARD SURGE CURRENT PER LEG

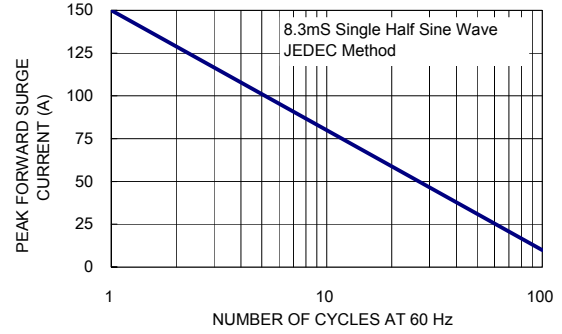

FIG. 3 TYPICAL FORWARD CHARACTERISTICS PER LEG

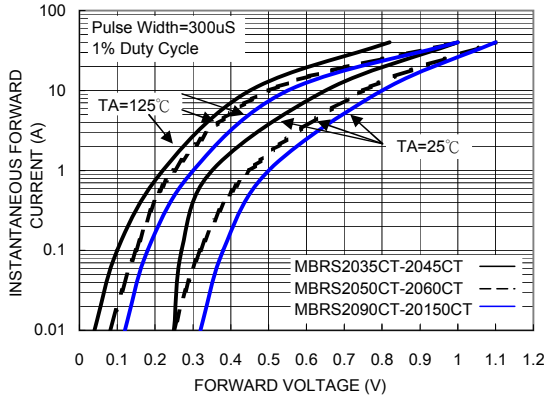

FIG. 4 TYPICAL REVERSE CHARACTERISTICS PER LEG

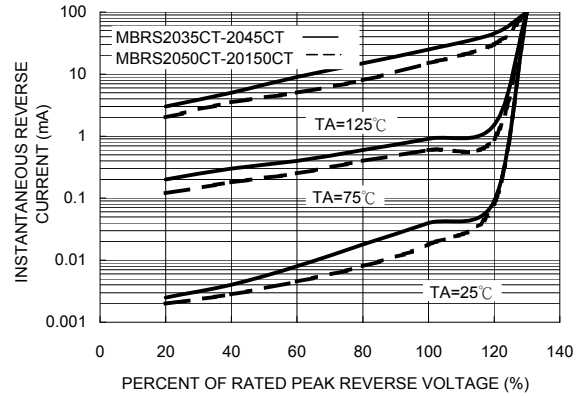

FIG. 5 TYPICAL JUNCTION CAPACITANCE PER LEG

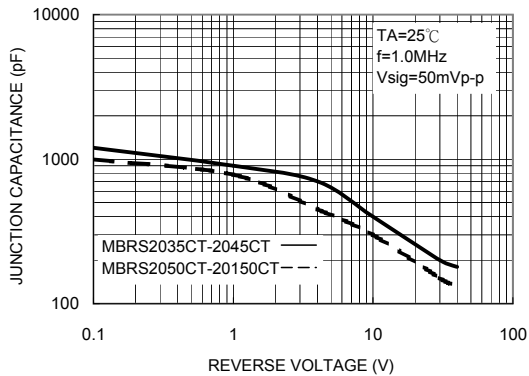

FIG. 6 TYPICAL TRANSIENT THERMAL IMPEDANCE PER LEG

