

Features and Benefits

- ❑ Low-Power Microcontroller-based Pressure-Temperature-Battery monitor, ideally suited for TPMS
- ❑ Different available pressure ranges up to 1400 kPa
- ❑ Measurement of car and truck tire pressure with 1% precision
- ❑ Sleep current 0.25 μ A
- ❑ Run mode current 340 μ A
- ❑ Temperature compensation of pressure sensor and oscillator
- ❑ Diagnostics for system error detection
- ❑ Motion detection by external shock sensor
- ❑ Robust package
- ❑ Shock survival up to 4000 G
- ❑ 7 GPIO pins (digital IN/OUT, analog IN)
- ❑ Compatible with existing Remote Keyless Entry (RKE) systems
- ❑ Very sensitive LF interface for short-range wireless communication using 125KHz
- ❑ Automotive qualified

Application Examples

- ❑ Continuous car and truck Tire Pressure Monitoring System (TPMS)
- ❑ Low-Power Wireless Pressure-Temperature-Battery sensor

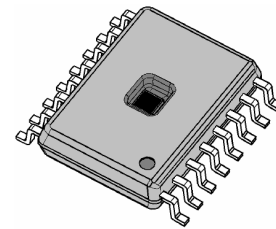

Ordering Information

Part No.	Temperature Range	Package Code	Option code
MLX91801	K (-40°C to 125°C)	XZ (SO16-wide)	EAF (FLASH)
MLX91801	K (-40°C to 125°C)	XZ (SO16-wide)	XXX (*) (ROM)

(*) dedicated ROM code is assigned after customer ROM order

Functional diagram

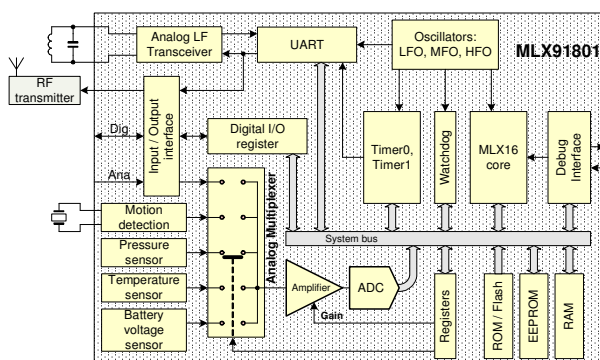

General Description

The MLX91801 is a System in a Package (SiP) combining an analog pressure sensor and a low-power sensor interface with an MLX16 microcontroller in a custom, pressure ported, plastic SO16 package.

Its primary use is in wireless TPMS applications. Using a suitable RF transmitter, the system can be made compliant with existing Remote Keyless Entry (RKE) systems.

Typical power consumption in standby mode is less than 0.25 μ A up to 25°C ambient temperature.

The MLX91801 accepts input from an external, shock or roll sensor enabling intelligent power management to maximize battery life.

The MLX91801 offers 1% Full Scale accuracy. The default pressure range is 100 – 800 kPa. Other ranges are available on request.

Table of Contents

Functional diagram	1
General Description	1
1. Glossary of Terms	3
2. Absolute Maximum Ratings	4
3. Pin Definitions and Descriptions	5
4. General Electrical Specifications	6
4.1 General Power Specification	6
4.2 Measurement Power Consumption	7
4.3 Digital Input/Output characteristics of IO1...IO7	8
5. Oscillators Specifications	8
6. Sensor Specific Specifications	9
7. LFR Specifications	10
8. Detailed General Description	11
8.1 MLX16 core	11
8.2 Oscillators	12
8.3 Timers	12
8.4 Memory	13
8.4.1 Program memory (ROM/FLASH)	13
8.4.2 EEPROM	13
8.4.3 RAM	13
8.4.4 Software Patch	14
8.5 Measurement Functions	14
8.5.1 Absolute Pressure sensor	14
8.5.2 Temperature sensor	14
8.5.3 Battery voltage sensor	15
8.6 Motion Detection Sensing	15
8.7 Amplifier and ADC	15
8.8 Communication	15
9. Application Information	17
9.1 Typical application diagram	17
9.2 Programming and debug interface	18
9.3 MLX91801 Demonstration Kit	18
10. Standard information regarding manufacturability of Melexis products with different soldering processes	19
11. ESD Precautions	20
12. Package Information	20
12.1 Package outline	20
13. Disclaimer	21

1. Glossary of Terms

ADC	Analog to Digital Converter
AGC	Automatic Gain Control
ASSP	Application Specific Standard Product
ESD	Electrostatic Discharge
GALS	Globally Asynchronous Locally Synchronous design
GPIO	General Purpose Input and Output
EEPROM	Electrical Erasable Programmable Read Only Memory
FLASH	Type of nonvolatile electrically erased and reprogrammed memory
FS	Full Scale
HFO	High Frequency Oscillator
LFO	Low Frequency Oscillator
LFR	Low Frequency Receiver
LSB	Least Significant Bit
MFO	Middle Frequency Oscillator
MEMS	Micro Electro-Mechanical Structure
MLX16	Melexis 16-bit microprocessor core
MSB	Most Significant Bit
NRZ	Non-return-to-zero line code
POR	Power-On Reset / Power Down
ROM	Read Only Memory
RAM	Random Access Memory
SIP	System In a Package
UART	Universal Asynchronous Receiver/Transmitter
WD	Watchdog Timer

- All voltages mentioned in the datasheet are referenced to the common ground (VSS pin) and all positive currents flow into the IC
- 100 kPa = 14.5038 psi (Pound per square inch) = 750.0639973 mmHg (height mercury) = 1 bar

2. Absolute Maximum Ratings

Parameter	Symbol	Min	Max	Unit	Comment
Supply Voltage (overvoltage)	V _{DD}	-0.5	5	V	
Supply Voltage (operating)	V _{DD}	2.05 1.8	3.6 3.6	V V	Operating within specifications All operations except measurement accuracy and LF communication
Input Voltage at any pin except pins LFP / LFN	V _{in1}	-0.5	V _{DD} +0.5	V	
Input Voltage at pins LFP / LFN	V _{in2}	-0.5	1	V	
Voltage difference between pins LFP and LFN	V _{in3}	-1	1	V	
Electrostatic Discharge: human body model machine model	V _{ESD}	-2 -200	2 200	kV V	
Latch-up withstand current	I _{LATCH}	-100	100	mA	
Measured pressure	P	0	1400	kPa	No Accuracy Degradation
Burst Pressure	P _{burst}	2000	-	kPa	
Constant Acceleration	A _{const}	-	2500	g	For any axis
Acceleration shock survival	A _{shock}	-	±4000	g	200µs, half-sine, for any axes
Vibration	A _{vibr}	-	50	g	200 Hz, 1 hour and 10...2000 Hz
Operating Temperature Range	T _A	-40	+150	°C	Limited Functionality at 125...150°C
Storage Temperature Range	T _S	-50	+150	°C	

Table 1: Absolute maximum ratings

Exceeding the absolute maximum ratings may cause permanent damage. Exposure to absolute-maximum-rated conditions for extended periods may affect device reliability.

3. Pin Definitions and Descriptions

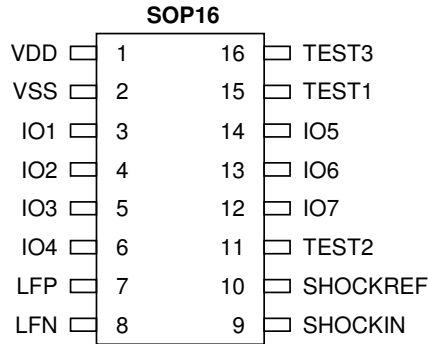

Pin №	Name	Type	Function
1	VDD	Supply	Battery Supply Voltage
2	VSS	Ground	Common Ground
3	IO1	Digital I/O or Analog Input	General purpose IO1 or UART Controlled
4	IO2	Digital I/O or Analog Input	General purpose IO2 or UART Controlled
5	IO3	Digital I/O or Analog Input	General Purpose IO3 or UART Controlled
6	IO4	Digital I/O or Analog Input	General Purpose IO4 or UART Controlled
7	LFP	Analog Input	LF Receiver Channel Positive Input
8	LFN	Analog Input	LF Receiver Channel Negative Input
9	SHOCKIN	Analog Input	Shock Sensor Input
10	SHOCKREF	Analog Input	Shock Sensor Reference Voltage
11	TEST2	Digital Output	Test output
12	IO7	Digital I/O or Analog Input	General Purpose IO7
13	IO6	Digital I/O or Analog Input	General Purpose IO6
14	IO5	Digital I/O or Analog Input	General Purpose IO5
15	TEST1	Digital Input	Test input 0
16	TEST3	Digital Input	Test input 1

Table 2: Pin definitions and descriptions

4. General Electrical Specifications

4.1 General Power Specification

DC Operating Parameters $T_A = -40^{\circ}\text{C}$ to 125°C , $V_{DD} = 1.8\text{V}$ to 3.6V (unless otherwise specified)

Parameter	Symbol	Test Conditions	Min	Typ	Max	Unit
Run mode Current Consumption	I_{RUN}	Voltage regulator is on 1 MHz MLX16 clock 4 MHz MLX16 clock	-	340 1.0	400 1.4	μA mA
Standby Current Consumption	I_{standby}	ROM version, LFO and POR are on, voltage regulator is off, $V_{DD} = 3.1\text{V}$ $T_A = 0^{\circ}\text{C}$ $T_A = -40$ to 25°C , $T_A = 85^{\circ}\text{C}$ $T_A = 125^{\circ}\text{C}$	-	0.18 0.25 2.0 11	- 0.5 - 26	μA μA μA μA
Power On Reset Threshold	V_{reset}		-	-	1.8	V
Power On Reset Hysteresis	V_{hyst}		40	-	200	mV
POR active time once supply voltage has risen above V_{reset} (*)			-	5...15	-	ms
Delay before POR becomes active once supply voltage has fallen below V_{reset} (*)	V_{delay}			1...10		ms

Table 3: General Power Specification

(*) The specified typical range is guaranteed by design and validated through characterization. The exact value depends on the behavior of the supply voltage.

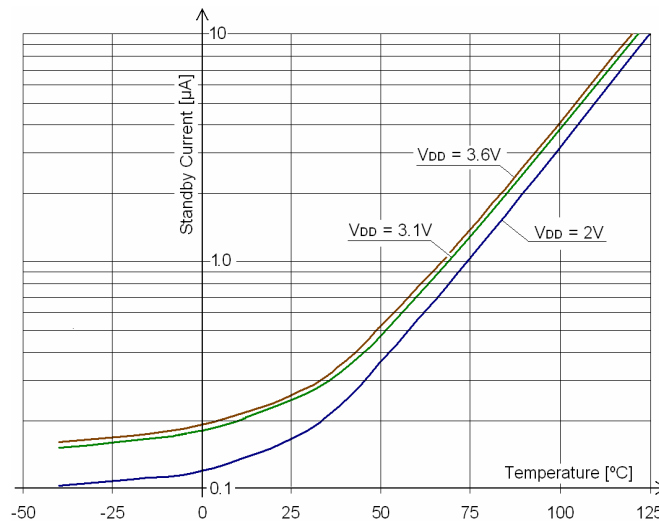

Fig. 1 MLX91801 typical standby current (internal voltage regulator is off)

4.2 Measurement Power Consumption

The table below includes the functional parameters obtained by utilizing the library firmware routines provided by Melexis. Please refer to Melexis library user manual for details.

DC Operating Parameters $T_A = -40^{\circ}\text{C}$ to 125°C , $V_{DD} = 2.05\text{V}$ to 3.6V (unless otherwise specified)

Parameter	Symbol	Min	Typ	Max	Unit
Battery Voltage Measurement					
Function "GetBattery":					
• execution time	t_{GB}	-	340	-	μs
• power consumption	Q_{GB}	-	0.15	0.19	$\mu\text{A}\cdot\text{s}$
Temperature Measurement					
Function "GetTemperature":					
• execution time	t_{GT}	-	200	-	μs
• power consumption	Q_{GT}	-	0.1	0.12	$\mu\text{A}\cdot\text{s}$
Function "CompensateTemperature":					
• execution time	t_{CT}	-	1000	-	μs
• power consumption	Q_{CT}	-	0.35	0.45	$\mu\text{A}\cdot\text{s}$
Pressure Measurement					
Function "GetPressure":					
• execution time	t_{GP}	-	200	-	μs
• power consumption	Q_{GP}	-	0.15	0.18	$\mu\text{A}\cdot\text{s}$
Function "TemperatureCompensatePressure":					
• execution time	t_{TCP}	-	620	-	μs
• power consumption	Q_{TCP}	-	0.2	0.25	$\mu\text{A}\cdot\text{s}$
Function "LinearizePressure":					
• execution time	t_{LP}	-	650	-	μs
• power consumption	Q_{LP}	-	0.23	0.28	$\mu\text{A}\cdot\text{s}$
Motion Detection Measurement					
Function "MotionPrologue":					
• execution time	t_{MP}	-	460	-	μs
• power consumption	Q_{MP}	-	0.1	0.12	$\mu\text{A}\cdot\text{s}$
Function "GetMotion":					
• execution time	t_{GM}	-	430	-	μs
• power consumption	Q_{GM}	-	0.12	0.14	$\mu\text{A}\cdot\text{s}$
Function "MotionEpilogue":					
• execution time	t_{ME}	-	40	-	μs
• power consumption	Q_{ME}	-	0.02	0.03	$\mu\text{A}\cdot\text{s}$

Table 4: Measurement Power Consumption

Note: The execution time can vary with HFO frequency and with values of input parameters of the library routines.

4.3 Digital Input/Output characteristics of IO1...IO7

DC Operating Parameters $T_A = -40^{\circ}\text{C}$ to 125°C , $V_{DD} = 2.05\text{V}$ to 3.6V (unless otherwise specified)

Parameter	Symbol	Test Condition	Min	Typical	Max	Unit
Output High Voltage	V_{OH}	$I_{LOAD} = 0.5\text{ mA}$	$V_{DD} - 0.5$	-	V_{DD}	V
Output Low Voltage	V_{OL}	$I_{LOAD} = 0.5\text{ mA}$	-	-	0.5	V
Input High Voltage (*)	V_{IH}		$0.7 \times V_{DD}$	-	$V_{DD} + 0.5$	V
Input Low Voltage (*)	V_{IL}		0	-	$0.3 \times V_{DD}$	V
Input High Current	I_{IH}	at V_{IH}	-1	-	1	μA
Input Low Current	I_{IL}	at V_{IL}	-1	-	1	μA

Table 5: Digital Input/Output characteristics

(*) The specified values are guaranteed by design

5. Oscillators Specifications

DC Operating Parameters $T_A = -40^{\circ}\text{C}$ to 125°C , $V_{DD} = 1.8\text{V}$ to 3.6V (unless otherwise specified)

Parameter	Symbol	Test Conditions	Min	Typ	Max	Units
High Frequency Oscillator Frequency	F_{HFO}	Clock Divider = 1	3.8	4	4.2	MHz
		Clock Divider = 4	0.950	1	1.05	MHz
High Frequency Oscillator Start-Up Time (*)	T_{SHF}		-	-	2	μs
Middle Frequency Oscillator Frequency	F_{MFO}		237.12	249.6	262.08	kHz
Middle Frequency Oscillator Start-Up Time (*)	T_{SMF}		-	-	80	μs
Low Frequency Oscillator, Frequency (LFO)	F_{LFO}	$V_{DD} = 2.05\text{V}$ to 3.6V	1.9	2	2.1	kHz
		$V_{DD} = 1.8\text{V}$ to 3.6V	1.8	2	2.2	kHz

Table 6: Oscillators Specifications

(*) The specified values are guaranteed by design and validated by characterization

6. Sensor Specific Specifications

DC Operating Parameters $T_A = -40^{\circ}\text{C}$ to 125°C , $V_{DD} = 2.05\text{V}$ to 3.6V (unless otherwise specified)

Parameter	Test Conditions	Min	Typ	Max	Units
Pressure Measurement Specifications for 100 to 800 kPa range, FS = 700 kPa (*)					
Measurement Error	$T_A = 0^{\circ}\text{C}$ to 50°C	-6.5	-	6.5	kPa
	$T_A = -40^{\circ}\text{C}$ to 125°C	-8.5	-	8.5	kPa
Additional Measurement Error with g load	per 1000 g (sensor facing out)		-0.67		% of FS
	per 1000 g (sensor facing axis)		0.8		% of FS
Drift over Life		-	< 5.6		kPa
Temperature Measurement Specific Specifications					
Measurement Error	$T_A = -20^{\circ}\text{C}$ to 70°C , $V_{DD} = 2.05\text{V}$ to 3.6V	-2	-	2	$^{\circ}\text{C}$
	$T_A = -40^{\circ}\text{C}$ to 125°C , $V_{DD} = 1.8\text{V}$ to 3.6V	-4	-	4	$^{\circ}\text{C}$
Drift over Life	$T_A = -40^{\circ}\text{C}$ to 125°C , $V_{DD} = 1.8\text{V}$ to 3.6V		< 1		$^{\circ}\text{C}$
Voltage Measurement Specific Specifications					
Measurement Error	$T_A = -40^{\circ}\text{C}$ to 125°C , $V_{DD} = 1.8\text{V}$ to 3.6V	-	-	50	mV
Drift over Life	$T_A = -40^{\circ}\text{C}$ to 125°C , $V_{DD} = 1.8\text{V}$ to 3.6V	-	< 10		mV
Motion Detection Specific Specification with external charge sensitive type shock sensor					
Sensitivity	Maximum amplification gain, charge sensitivity of the external shock sensor = 0.14 pC/g	1500	-	-	LSB/g
Pk-Pk Noise	100 samples @ 3 ms, maximum amplification gain, disabled internal low pass filter, shock sensor capacitance = 240 pF $V_{DD} = 2.05 \text{ V}$ $V_{DD} = 3.1 \text{ V}$	-	< 600	-	LSB
		-	< 400	-	LSB
External leakage between pins SHOCKIN and VSS/VDD		-	-	0.1	nA
Signal Bandwidth	Without internal low pass filter	1	-	50	Hz

Table 7: Sensor Specific specifications

(*) For customized pressure ranges, please contact your Melexis representative

7. LFR Specifications

DC Operating Parameters $T_A = -40^{\circ}\text{C}$ to 125°C , $V_{DD} = 2.05\text{V}$ to 3.6V (unless otherwise specified)

Parameter	Symbol	Test Conditions	Min	Typ	Max	Units
Carrier Frequency	F_{LFR}		50	125	200	kHz
Data Rate	D_R		3.51	3.90	4.29	kbits/sec
AGC Settling Time (*)	T_{SAGC}	From turning on until active state	-	0.7	3	ms
Input Sensitivity No Detect level Detect level	S_{NODET} S_{DET}	Maximal gain and 125 kHz input frequency	0.17 -	- -	- 0.68	mV p-p mV p-p
Input Capacitance between pins LFP and LFN (*)	C_{LFRINP}		-	-	2	pF
AGC Minimum Resistance (*)	R_{AGCMIN}	Maximum input signal	-	-	200	Ω
AGC Maximum Resistance (*)	R_{AGCMAX}	Minimum input signal	10	-	-	M Ω
Q factor of external LC circuit between LFP and LFN pins	Q_{LC}		-	-	15	-
Q factor of external Initiator (Transmit device)	Q_{EXT}		-	-	7	-
LF Talkback Resistance	R_{TB}		-	350	700	Ω
LF receiving and decoding Current Consumption (*)	I_{LFRD}	Includes all blocks involved in the LF message receiving and decoding (LFR, UART, MFO)	-	16	-	μA

Table 8: LFR Specifications

(*) The specified values are guaranteed by design and validated by characterization

8. Detailed General Description

The MLX91801 is designed for TPMS applications. It contains peripheral blocks that include software control of the sensor interface, communication interface and power management supporting extremely low power consumption in the standby mode.

The device is capable of measuring pressure, temperature and supply voltage. The pressure sensing element is a MEMS based absolute resistive bridge pressure sensor mounted on the ASSP. Together with an external shock sensor the device can detect motion.

The communication interface provides commands receiving and sending data to the host system.

7 General Input and Output ports can be used for simple digital input-output operations or for alternative functions like analog input or digital outputs of the UART.

The standard software library with low-level routines gives access to all the IC's functions. Application examples provided by Melexis offer an entry level introduction to the MLX16 programming.

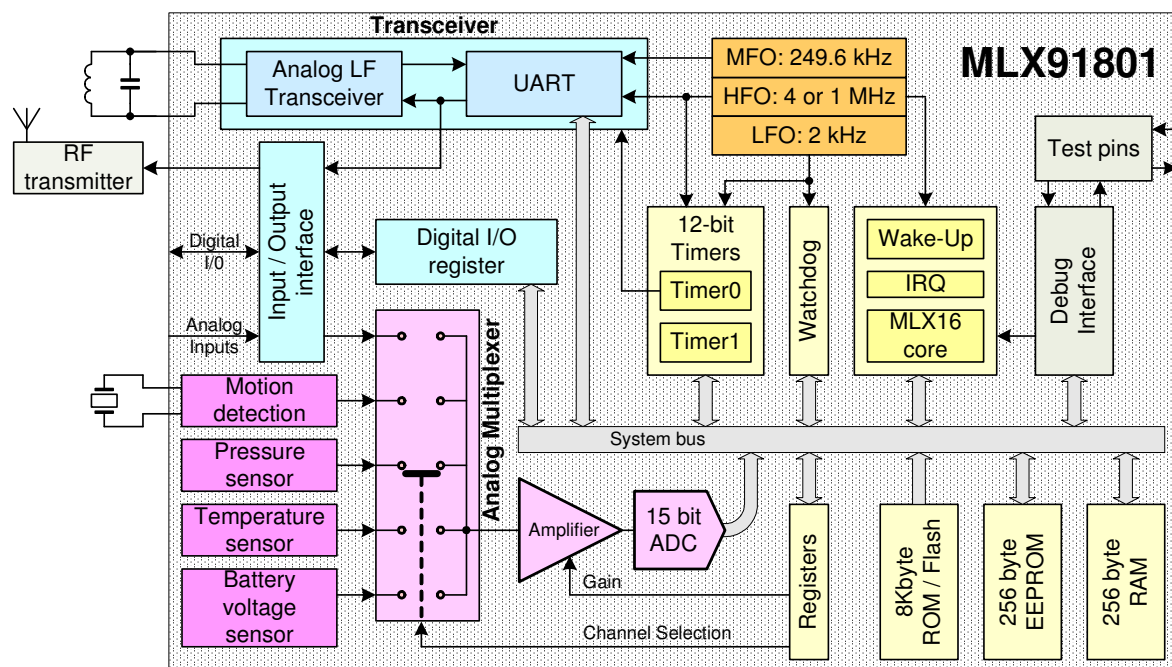

Fig. 2 MLX91801 block diagram

8.1 MLX16 core

The MLX91801 is based on the MLX16 16-bit RISC microcontroller core clocked by a trimmed internal RC oscillator (HFO). The core provides a computation speed up to 1 MIPS with 4MHz or 0.25 MIPS with 1 MHz clock frequency.

The MLX16 core instruction set allows word, byte and bit manipulation. Seven levels of interrupt priority together with 3 bit software priority level provide flexible interrupt handling, while the Protected and User execution modes together with exceptions detection supports a high security level.

The Wake-Up controller is responsible for the MLX16 standby mode. The controller can force the MLX16 to sleep and can awake it if any of programmed in advance external events happened.

8.2 Oscillators

Being designed according to the GALS concept the MLX91801 digital part is clocked by different sources. By controlling the clocks one can optimize the current consumption of the MLX91801.

There are three, trimmed on-chip, RC oscillators: HFO, MFO and LFO.

The HFO provides 4 MHz or 1 MHz clock for the microcontroller. The 1 MHz clock is obtained after a digital divider and is normally used to get a lower current consumption when computation speed is not important.

The MFO generates a reference frequency with a nominal value of 249.6 kHz that is used to synchronize transmitting of the RF/LF messages as well as receiving of the LF commands.

The HFO/MFO is automatic turned off if all of its targets are in the sleep mode.

The LFO has a 2 kHz nominal frequency. It cannot be turned off and is utilized by the watchdog timer. Two other available timers can also utilize the LFO to optimize current consumption.

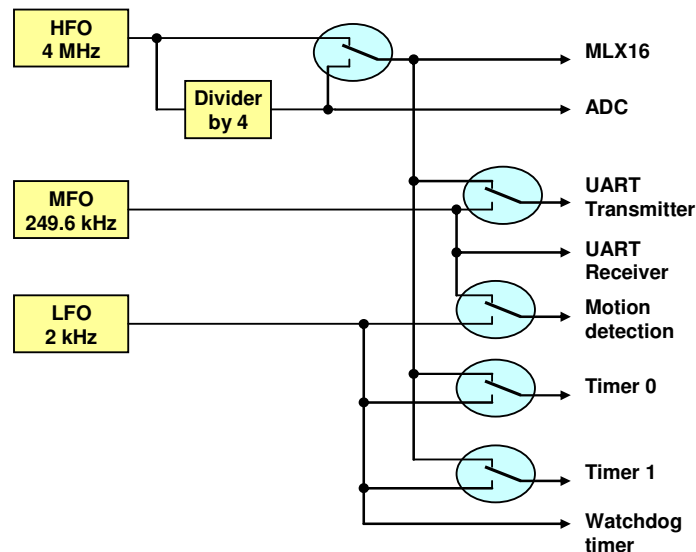

Fig. 3 MLX91801 oscillators

8.3 Timers

The MLX91801 has two similar 12 bit Timers (Timer0 and Timer1) supporting 4 different operation modes (Count, Multiple, Single and Disable). The timers can be clocked independently by LFO or HFO and depending on that they can be used to generate a time delay of up to 2 seconds with ± 1 ms tolerance, 4 ms with ± 2 μ s tolerance or up to 1 ms by keeping ± 0.5 μ s tolerance.

In addition the Watchdog timer is included in the ASSP to protect software from “endless loops” and to generate long time delays (up to 70 seconds). The second feature can be useful to save battery life when a sleeping ASSP can be occasionally awakened by the watchdog to be active for a short time.

8.4 Memory

A single MLX16 address space is shared between the configuration registers and three types of memory: program memory, the EEPROM and the RAM. The nonvolatile program memory includes executable firmware code. The EEPROM is normally used to store identification codes, calibration or other coefficients. Besides, the EEPROM can be used to correct a ROM firmware code if needed. The RAM stores an intermediate data and supports a software stack.

8.4.1 Program memory (ROM/FLASH)

The program memory occupies 8 Kbytes in the MLX16 address space and is organized as 4096x16-bit memory array.

Normally the program memory is a factory programmed ROM with customer's proprietary firmware (production version). As well, a FLASH memory version is available for customer's application software development and prototyping. The FLASH fully replaces the ROM in the MLX16 address space, so after debugging the firmware written for the FLASH can be factory programmed in the ROM without any modifications.

The ROM is accessible without any delays for any available MLX16 clock, while the FLASH requires a single MLX16 clock delay (250 ns) for 4 MHz MLX16 clock (inserted automatically).

8.4.2 EEPROM

The ML91801 has 256 bytes of EEPROM that is protected against data loss by utilizing a Hamming code. The EEPROM can be read, written or erased. Minimal number of EEPROM write cycles is 10000 with data retention time > 10 years.

The EEPROM is mapped as follows (from low to high addresses):

- 36 bytes: For Melexis use only
- 12 bytes: Customer protected area: once locked by the customer, the area becomes Read only
- 16 bytes: Customer unprotected area
- 176 bytes: Application specific data or/and Software patch area
- 16 bytes: Software patch area configuration data

The EEPROM is read by any MLX16 read instruction without additional delay at 1 MHz MLX16 clock, while at 4 MHz one period of the clock (250 ns) is automatically added to the EEPROM read cycle.

While EEPROM data is not needed, it can be temporarily disabled by firmware to decrease the current consumption.

8.4.3 RAM

The RAM size is 256 Bytes organized as 128x16-bit memory array. The RAM can be read and written in "word", "byte" and "bit" format without delays for any available MLX16 clock frequency. The RAM retains memory over full operating temperature and voltage range for all modes. RAM power supply is kept on in the standby mode.

8.4.4 Software Patch

The Patch function allows making corrections in the firmware code without changing the ROM content. Up to 2 locations (instructions) anywhere within the ROM program can be replaced by jumps to the patch area in the EEPROM. Being located in the EEPROM the patch function can be reconfigured when required, for example for adaptation of ROM firmware for different application requirements.

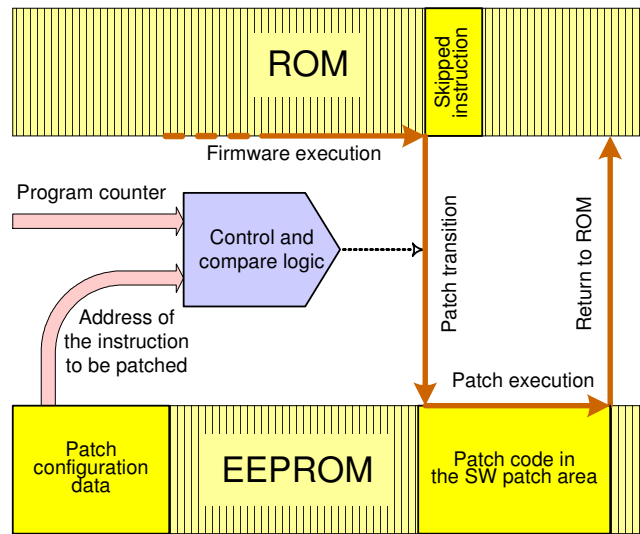

Fig. 4 Simplified patching scheme

8.5 Measurement Functions

Low level routines are available as a set of library functions including measurement functions that fully control the MLX91801 sensor interface.

A voltage reference source generates a voltage independent of the battery state. The output of the pressure, temperature, motion sensing and the voltage sensor are differential signals that are multiplexed on the input of the signal conditioning chain. The measurements are converted to a digital signal by an analog to digital converter (ADC). The ADC output values are linearized, the offset is removed and the sensitivity is adjusted by utilizing the calibration constants that are stored in the EEPROM. The calibration constants are determined during the production test. The measurements are optimized for low power consumption.

8.5.1 Absolute Pressure sensor

The pressure sensor is a separate silicon MEMS die based on a piezo-resistive Wheatstone bridge. A built-in test circuit checks bond wire integrity. The pressure measurement is made by utilizing a library routine that performs the conversion and temperature compensation. The default pressure ranges is 100 - 800 kPa. Other ranges can be made available on request.

8.5.2 Temperature sensor

The temperature measurement is derived from the voltage reference that generates a voltage that is linear with the temperature and is independent of the supply voltage. The temperature sensor is controlled by a library routine and can be shut down when not in use.

8.5.3 Battery voltage sensor

The Battery voltage sensor is used to monitor a battery discharge level. The battery supply voltage is measured indirectly through the resistive divider and relative to the internal voltage reference. The final value is calculated by a library routine. To reduce current consumption, the resistance divider can be disabled.

8.6 Motion Detection Sensing

The motion detection utilizes an external low cost piezoelectric ceramic transducer to detect motion. When not in use the motion sensor interface shall be shut down by a library routine to reduce current consumption.

8.7 Amplifier and ADC

There is a programmable amplifier before the ADC. The amplifier has a selectable gain that is controlled by the application software. The ADC features 15 bit resolution and is monotonic by design.

8.8 Communication

Communication with the ASSP is possible via the low frequency (LF) transceiver and the UART.

The LF transceiver is designed to work in 50...200 kHz carrier frequency range. Receiver part of the LF transceiver has an automatic gain control schematic and demodulator. Transmission through the LF transceiver is possible by antenna coil modulation.

Unlike of the LF transceiver the UART is a fully digital block responsible for data conversion from parallel to 1-bit serial format for transmission and vice versa on reception. The serial format is supported in the NRZ and Manchester codes. Both (transmitter and receiver) parts of the UART have data buffers with data flow control hardware.

The UART doesn't require firmware support for data coding or encoding and hence the MLX16 core can be halted during the conversion to decrease power consumption. In turn the UART generates 6 types of interruptions that can wake up the microprocessor.

The UART receiver decodes the LF input signal from a modulated signal to binary data to be read by firmware from the data buffer register. To prevent accepting an alien LF-telegram the UART receiver includes a hardware detection of a 16 bit ID number. The UART receiver generates interruptions when:

- an expected ID number is received (IRQRxDAT);
- a new correct data is received (IRQRxDAT);
- the receiver buffer contains an incorrect data because of its overflow or a Manchester encoding error (IRQRxERR).

The UART transmitter converts up to 8 parallel bits prepared in advance by firmware in the buffer register to the 1-bit sequence in Manchester or NRZ format. The coded binary sequence can be directed to be sent by the LF transceiver or by an external RF transmitter. During sending, a new value can be loaded into the buffer register to ensure an unbroken serial data stream. If there is no data to send, the UART transmitter will be stopped. The UART transmitter generates interruptions when:

- the buffer register is empty and hence is ready to accept new data to be sent (IRQTxEEMP);
- the UART transmitter is stopped (IRQTxSTP);
- data buffer overflow is detected (IRQTxOVF).

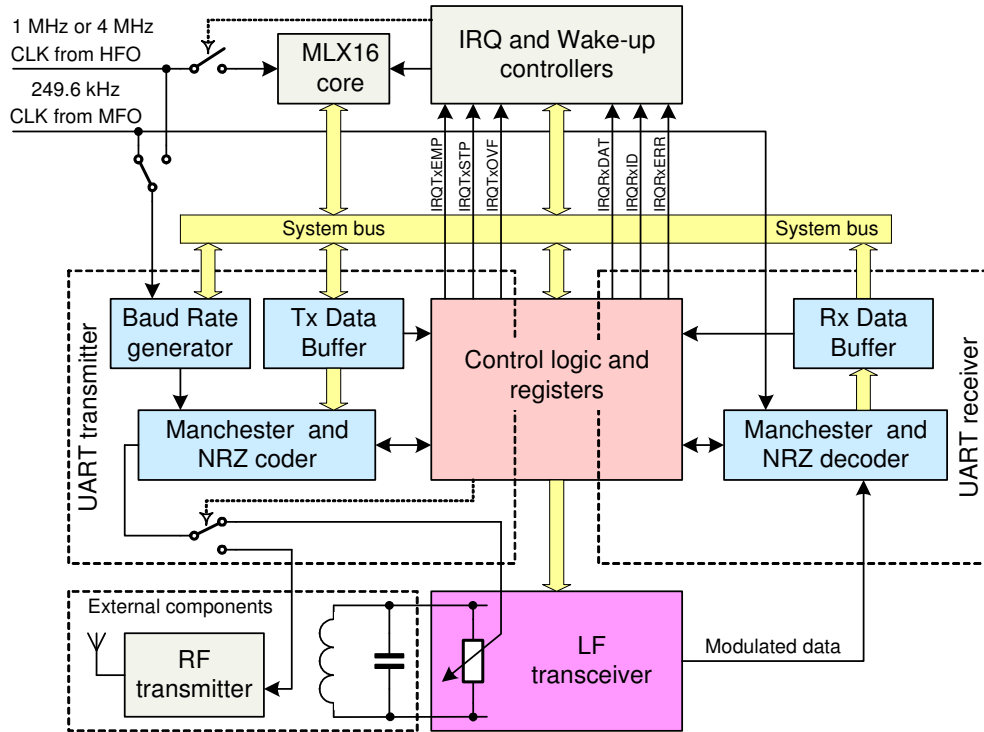

Fig. 5 Simplified functional diagram of the UART and LF transceiver

9. Application Information

9.1 Typical application diagram

A typical scheme of the tire pressure sensor shown on figure 6 includes:

- MLX91801 core IC
- MLX72013 433MHz FSK/ASK transmitter working in FSK mode
Note: To support 315 MHz RF channel the TH72005 FSK/ASK transmitter from Melexis is recommended.
- Input LC circuit (L1, C2) adjusted to the desired LF carrier frequency
- Charge sensitivity type shock sensor Q1
- 27.120 MHz fundamental wave crystal Q2
- Capacitors C3 and C4 with values that depend on the parameters of the crystal Q1
- Resistor R1 selecting an output RF power
- Valve stem antenna matching circuit (L2, L3, C6 and C7)
- Decoupling capacitors C1 and C5
- 3 Volt Battery

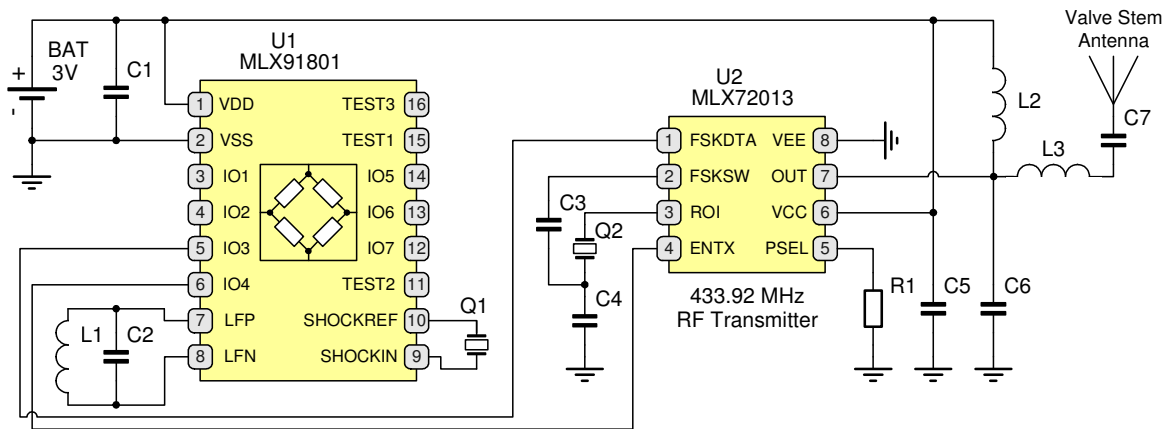

Fig. 6 Schematic example of the tire pressure sensor based on the MLX91801

9.2 Programming and debug interface

Programming and Debug Interface provides communication with Melexis programming and debug hardware like “E-mlx MM” or “Mini E-mlx”. With powerful PC software like Melexis Interactive Debugger, Mlx GCC compiler, Mlx16 Simulator and E-mlx Programmer it creates complete integrated programming and debug environment.

The MLX91801 ASSP supports the Melexis Programming and Debug Interface by 3 dedicated pins: TEST1, TEST2 and TEST3. To be compatible with Melexis hardware tools all those pins together with the common pin VSS should be wired to a standard Mini-DIN9 connector.

Figure 7 shows a connection example of the MLX91801 IC with the Mini E-mlx programmer. The E-Mlx MM programmer interface requires two additional 470Ω pull-up resistors connecting the TEST1 and TEST3 nodes with the VDD node.

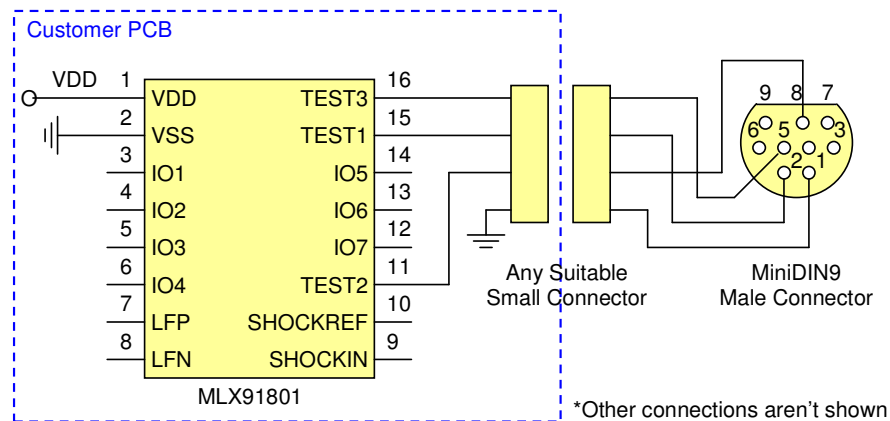

Fig. 7 Example of a MLX91801 interface with the Mini E-mlx programmer

9.3 MLX91801 Demonstration Kit

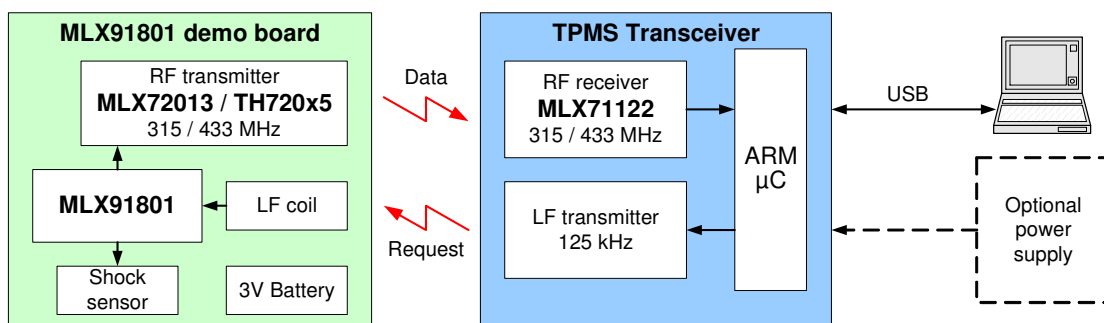

Fig. 8 DK91801 block diagram

Figure 8 shows a block diagram of the Melexis TPMS solution demo kit that is available for testing and demo purposes. Demo board uses the MLX91801 TPMS sensor and TH720x5 RF transmission IC. The kit comes with an LF/RF transceiver and antenna, with USB connection to a computer and a read out software.

10. Standard information regarding manufacturability of Melexis products with different soldering processes

Our products are classified and qualified regarding soldering technology, solderability and moisture sensitivity level according to following test methods:

Reflow Soldering SMD's (Surface Mount Developes)

- IPC/JEDEC J-STD-020
Moisture/Reflow Sensitivity Classification for Nonhermetic Solid State Surface Mount Devices (classification reflow profiles according to table 5-2)
- EIA/JEDEC JESD22-A113
Preconditioning of Nonhermetic Surface Mount Devices Prior to Reliability Testing (reflow profiles according to table 2)

Wave Soldering SMD's (Surface Mount Developes) and THD's (Through Hole Developes)

- EN60749-20
Resistance of plastic- encapsulated SMD's to combined effect of moisture and soldering heat
- EIA/JEDEC JESD22-B106 and EN60749-15
Resistance to soldering temperature for through-hole mounted devices

Iron Soldering THD's (Through Hole Developes)

- EN60749-15
Resistance to soldering temperature for through-hole mounted devices

Solderability SMD's (Surface Mount Developes) and THD's (Through Hole Developes)

- EIA/JEDEC JESD22-B102 and EN60749-21
Solderability

For all soldering technologies deviating from above mentioned standard conditions (regarding peak temperature, temperature gradient, temperature profile etc) additional classification and qualification tests have to be agreed upon with Melexis.

The application of Wave Soldering for SMD's is allowed only after consulting Melexis regarding assurance of adhesive strength between device and board.

Melexis is contributing to global environmental conservation by promoting **lead free** solutions. For more information on qualifications of **RoHS** compliant products (RoHS = European directive on the Restriction Of the use of certain Hazardous Substances) please visit the quality page on our website: <http://www.melexis.com/quality.asp>

11. ESD Precautions

Electronic semiconductor products are sensitive to Electro Static Discharge (ESD). Always observe Electro Static Discharge control procedures whenever handling semiconductor products.

12. Package Information

12.1 Package outline

The MLX91801 is a System In Package. It contains an ASSP chip and a sensor chip in a custom made package with a cavity on top. The package footprint is compatible with a SO16 wide body IC

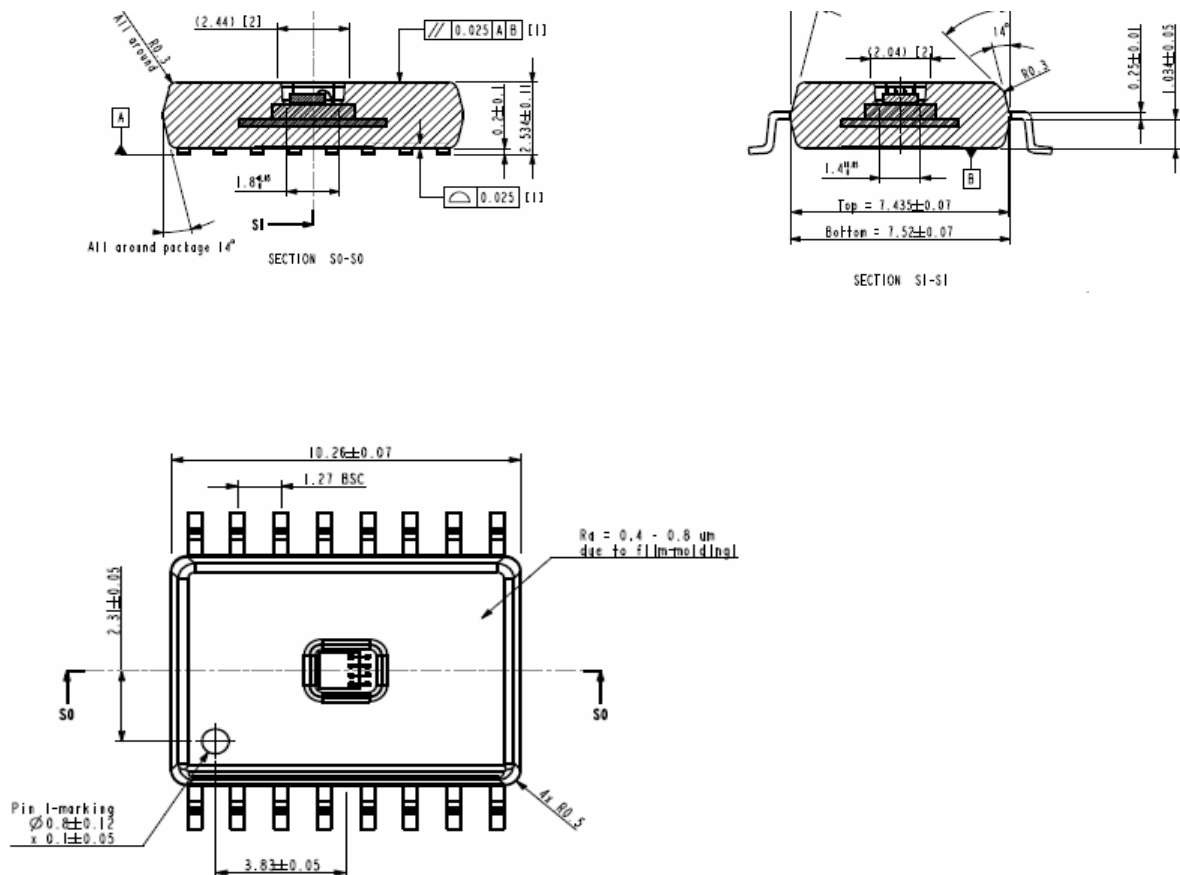

13. Disclaimer

Devices sold by Melexis are covered by the warranty and patent indemnification provisions appearing in its Term of Sale. Melexis makes no warranty, express, statutory, implied, or by description regarding the information set forth herein or regarding the freedom of the described devices from patent infringement. Melexis reserves the right to change specifications and prices at any time and without notice. Therefore, prior to designing this product into a system, it is necessary to check with Melexis for current information. This product is intended for use in normal commercial applications. Applications requiring extended temperature range, unusual environmental requirements, or high reliability applications, such as military, medical life-support or life-sustaining equipment are specifically not recommended without additional processing by Melexis for each application.

The information furnished by Melexis is believed to be correct and accurate. However, Melexis shall not be liable to recipient or any third party for any damages, including but not limited to personal injury, property damage, loss of profits, loss of use, interrupt of business or indirect, special incidental or consequential damages, of any kind, in connection with or arising out of the furnishing, performance or use of the technical data herein. No obligation or liability to recipient or any third party shall arise or flow out of Melexis' rendering of technical or other services.

© 2005 Melexis NV. All rights reserved.

For the latest version of this document, go to our website at
www.melexis.com

Or for additional information contact Melexis Direct:

Europe, Africa, Asia:
Phone: +32 1367 0495
E-mail: sales_europe@melexis.com

America:
Phone: +1 248 306 5400
E-mail: sales_usa@melexis.com

ISO/TS 16949 and ISO14001 Certified