

## Features

- Double-conversion superhet architecture for low high degree of image rejection
- FSK demodulation with phase-coincidence demodulator
- Low current consumption in active mode and very low standby current
- Switchable LNA gain for improved dynamic range
- RSSI allows signal strength indication and ASK detection

## Ordering Information

### Part No.

EVB71112-868-FSK-C  
EVB71112-868-ASK-C

EVB71112-915-FSK-C  
EVB71112-915-ASK-C

\* EVB71112-XXX-YYY-C with XXX = Reception frequency (868.3MHz or 915MHz) and YYY = Modulation (FSK or ASK).  
\*\* The evaluation board is supplied with a SMA connector.

## Application Examples

- Tire Pressure Monitoring Systems (TPMS)
- Remote Keyless Entry (RKE)
- Wireless access control
- Alarm and security systems
- Garage door openers
- Remote Controls
- Home and building automation
- Low-power telemetry systems

## Evaluation Board



## General Description

The TH71112 FSK/ASK double-conversion superheterodyne receiver IC is designed for applications in the European 868 MHz industrial-scientific-medical (ISM) band, according to the EN 300 220 telecommunications standard. It can also be used for any other system with carrier frequencies ranging from 750 MHz to 990 MHz (e.g. for applications to FCC part 15).

## Document Content

<b>1</b>	<b>Theory of Operation</b>	<b>3</b>
1.1	General	3
1.2	EVB Technical Data Overview	3
1.3	Block Diagram	4
1.4	Mode Configurations	4
1.5	LNA GAIN Control	4
1.6	Frequency Planning	4
1.6.1	Selected Frequency Plans	5
1.6.2	Maximum Frequency Coverage	5
<b>2</b>	<b>Application Circuits</b>	<b>6</b>
2.1	FSK Application Circuit	6
2.1.1	Circuit Diagram for FSK Reception	6
2.1.2	Board Component Values for FSK	7
2.1.3	Component Arrangement Top Side for FSK Reception	8
2.2	ASK Application Circuit	9
2.2.1	Circuit Diagram for ASK Reception	9
2.2.2	Board Component Values for ASK	10
2.2.3	Component Arrangement Top Side for ASK Reception	11
<b>3</b>	<b>Evaluation Board Layouts</b>	<b>12</b>
<b>4</b>	<b>Package Description</b>	<b>13</b>
4.1	Soldering Information	13
<b>5</b>	<b>Disclaimer</b>	<b>14</b>

## 1 Theory of Operation

### 1.1 General

With the TH71112 receiver chip, various circuit configurations can be arranged in order to meet a number of different customer requirements. For FSK reception the IF tank used in the phase coincidence demodulator can be constituted by an external ceramic discriminator. In ASK configuration, the RSSI signal is fed to an ASK detector, which is constituted by the operational amplifier.

The superheterodyne configuration is double conversion where MIX1 and MIX2 are driven by the internal local oscillator signals LO1 and LO2, respectively. This allows a high degree of image rejection, achieved in conjunction with an RF front-end filter. Efficient RF front-end filtering is realized by using a SAW, ceramic or helix filter in front of the LNA and by adding an LC filter at the LNA output.

A single-conversion variant, called TH71111, is also available. Both Receiver ICs have the same die. At the TH71111 the second mixer MIX2 operates as an amplifier.

The TH71112 receiver IC consists of the following building blocks:

- PLL synthesizer (PLL SYNTH) for generation of the first and second local oscillator signals LO1 and LO2, parts of the PLL SYNTH are: the high-frequency VCO1, the feedback dividers DIV\_16 and DIV\_2, a phase-frequency detector (PFD) with charge pump (CP) and a crystal-based reference oscillator (RO)
- Low-noise amplifier (LNA) for high-sensitivity RF signal reception
- First mixer (MIX1) for down-conversion of the RF signal to the first IF (IF1)
- Second mixer (MIX2) for down-conversion of the IF1 to the second IF (IF2)
- IF amplifier (IFA) to amplify and limit the IF2 signal and for RSSI generation
- Phase coincidence demodulator (DEMOD) with third mixer (MIX3) to demodulate the IF signal
- Operational amplifier (OA) for data slicing, filtering and ASK detection
- Bias circuitry for bandgap biasing and circuit shutdown

### 1.2 EVB Technical Data Overview

- |   |   |
|---|---|
| <input type="checkbox"/> Input frequency range: 750 MHz to 990 MHz                            | <input type="checkbox"/> Range of first IF2: 400 kHz to 22 MHz  |
| <input type="checkbox"/> Power supply range: 2.3 V to 5.5 V @ ASK<br>2.7 V to 5.5 V @ FSK     | <input type="checkbox"/> Maximum input level: -10 dBm @ ASK<br>0 dBm @ FSK  |
| <input type="checkbox"/> Temperature range: -40 °C to +85 °C                                  | <input type="checkbox"/> Image rejection: > 60 dB (e.g. with 868.3 MHz<br>SAW front-end filter and at 10.7 MHz IF2) |
| <input type="checkbox"/> Standby current: 50 nA   | <input type="checkbox"/> Spurious emission: < -70 dBm   |
| <input type="checkbox"/> Operating current: 7.5 mA @ low gain mode<br>9.2 mA @ high gain mode | <input type="checkbox"/> Input frequency acceptance range: up to ±100 kHz   |
| <input type="checkbox"/> Sensitivity: -109 dBm @ ASK 1)<br>-103 dBm @ FSK 2)                  | <input type="checkbox"/> RSSI range: 70 dB  |
| <input type="checkbox"/> Range of first IF1: 10 MHz to 80 MHz                                 | <input type="checkbox"/> FSK deviation range: ±2.5 kHz to ±80 kHz   |

- 1) at 4 kbps NRZ, BER =  $3 \cdot 10^{-3}$ , 180 kHz IF filter BW, incl. 3 dB SAW front-end-filter loss
- 2) at 4 kbps NRZ, BER =  $3 \cdot 10^{-3}$ , ± 20 kHz FSK deviation, 180 kHz IF filter BW, incl. 3 dB SAW front-end-filter loss

For more detailed information, please refer to the latest TH71112 data sheet revision

### 1.3 Block Diagram

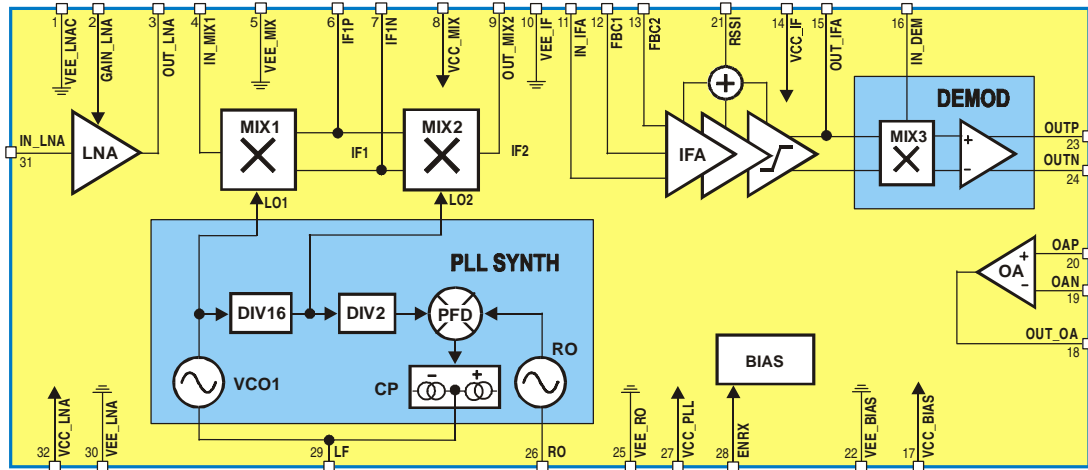

Fig. 1: TH71112 block diagram

### 1.4 Mode Configurations

ENRX	Mode	Description
0	RX standby	RX disabled
1	RX active	RX enable

**Note:** ENRX are pulled down internally

### 1.5 LNA GAIN Control

V <sub>GAIN_LNA</sub>	Mode	Description
< 0.8 V	HIGH GAIN	LNA set to high gain
> 1.4 V	LOW GAIN	LNA set to low gain

**Note:** hysteresis between gain modes to ensure stability

### 1.6 Frequency Planning

Frequency planning is straightforward for single-conversion applications because there is only one IF that can be chosen, and then the only possible choice is low-side or high-side injection of the LO signal (which is now the one and only LO signal in the receiver).

The receiver's double-conversion architecture requires careful frequency planning. Besides the desired RF input signal, there are a number of spurious signals that may cause an undesired response at the output. Among them are the image of the RF signal (that must be suppressed by the RF front-end filter), spurious signals injected to the first IF (IF1) and their images which could be mixed down to the same second IF (IF2) as the desired RF signal (they must be suppressed by the LC filter at IF1 and/or by low-crosstalk design).

By configuring the TH71112 for double conversion and using its internal PLL synthesizer with fixed feedback divider ratios of N1 = 16 (DIV\_16) and N2 = 2 (DIV\_2), four types of down-conversion are possible: low-side injection of LO1 and LO2 (**low-low**), LO1 low-side and LO2 high-side (**low-high**), LO1 high-side and LO2 low-side (**high-low**) or LO1 and LO2 high-side (**high-high**). The following table summarizes some equations that are useful to calculate the crystal reference frequency (REF), the first IF (IF1) and the VCO1 or first LO frequency (LO1), respectively, for a given RF and second IF (IF2).

Injection type	high-high	low-low	high-low	low-high
REF	$(RF - IF2)/30$	$(RF - IF2)/34$	$(RF + IF2)/30$	$(RF + IF2)/34$
LO1	$32 \bullet REF$	$32 \bullet REF$	$32 \bullet REF$	$32 \bullet REF$
IF1	$LO1 - RF$	$RF - LO1$	$LO1 - RF$	$RF - LO1$
LO2	$2 \bullet REF$	$2 \bullet REF$	$2 \bullet REF$	$2 \bullet REF$
IF2	$LO2 - IF1$	$IF1 - LO2$	$IF1 - LO2$	$LO2 - IF1$

### 1.6.1 Selected Frequency Plans

The following table depicts crystal, LO and image signals considering the examples of 868.3 MHz and 915 MHz RF reception at IF2 = 10.7 MHz. The columns in bold depict the selected frequency plans to receive at 868.3 MHz and 915 MHz, respectively.

Signal type	RF = 868.3 MHz	RF = 868.3 MHz	RF = 868.3 MHz	RF = 868.3 MHz	RF = 915 MHz	RF = 915 MHz	RF = 915 MHz	RF = 915 MHz
Injection type	high-high	<b>low-low</b>	high-low	low-high	high-high	<b>low-low</b>	high-low	low-high
REF / MHz	28.58667	<b>25.22353</b>	29.3	25.85294	30.14333	<b>26.59706</b>	30.85667	27.22647
LO1 / MHz	914.77333	<b>807.15294</b>	937.6	827.29412	964.58667	<b>851.10588</b>	987.41333	871.24706
IF1 / MHz	46.47333	<b>61.14706</b>	69.3	41.00588	49.58667	<b>63.89412</b>	72.41333	43.75294
LO2 / MHz	57.17333	<b>50.44706</b>	58.6	51.70588	60.28667	<b>53.19412</b>	61.71333	54.45294
RF image/MHz	961.24667	<b>746.00588</b>	1006.9	786.28824	1014.17	<b>787.21176</b>	1059.83	827.49412
IF1 image/MHz	67.87333	<b>39.74706</b>	47.9	62.40588	70.98667	<b>42.49412</b>	51.01333	65.15294

### 1.6.2 Maximum Frequency Coverage

Parameter	f <sub>min</sub>	f <sub>max</sub>
Injection type	high-low	low-low
RF / MHz	739.3	998.825
REF / MHz	25.0	29.0625
LO1 / MHz	800	930
IF1 / MHz	60.7	68.825
LO2 / MHz	50.0	58.125
IF2 / MHz	10.7	10.7

The selection of the reference crystal frequency is based on some assumptions. As for example: the first IF and the image frequencies should not be in a radio band where strong interfering signals might occur (because they could represent parasitic receiving signals), the LO1 signal should be in the range of 800 MHz to 930 MHz (because this is the optimum frequency range of the VCO1). Furthermore the first IF should be as high as possible to achieve highest RF image rejection.

## 2 Application Circuits

### 2.1 FSK Application Circuit

#### 2.1.1 Circuit Diagram for FSK Reception

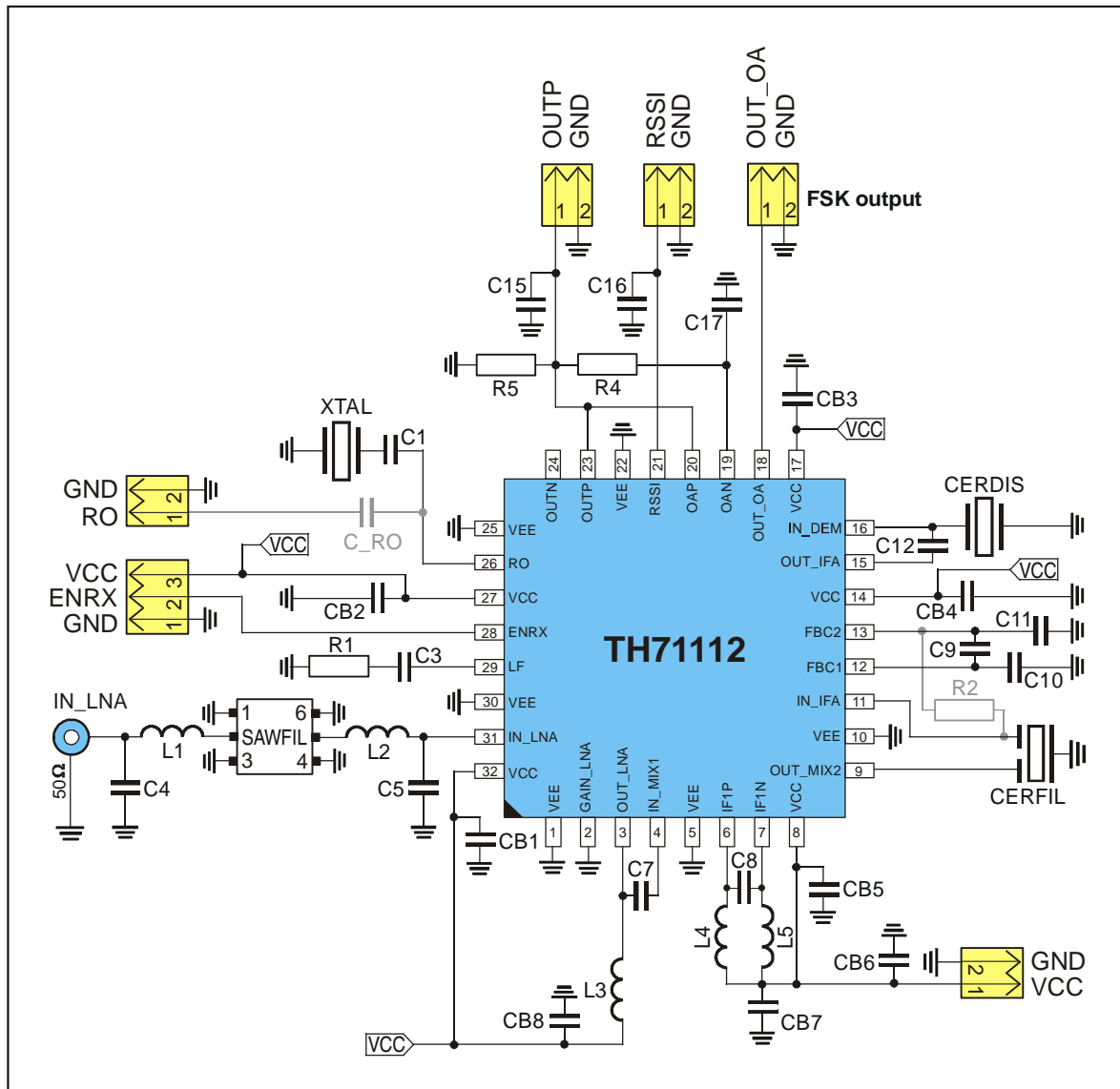

#### Circuit Features

- Tolerates input frequency variations
- Well-suited for NRZ, Manchester and similar codes

### 2.1.2 Board Component Values for FSK

Part	Size	Value @ 868.3 MHz	Value @ 915 MHz	Tolerance	Description
C1	0805	22 pF	22 pF	±5%	crystal series capacitor
C3	0603	1 nF	1 nF	±10%	loop filter capacitor
C4	0603	4,7 pF	NIP	±5%	capacitor to match SAW filter input
C5	0603	2.7 pF	NIP	±5%	capacitor to match SAW filter output
C7	0603	1.0 pF	0.68 pF	±5%	MIX1 input matching capacitor
C8	0603	22 pF	22 pF	±5%	IF1 tank capacitor
C9	0603	33 nF	33 nF	±10%	IFA feedback capacitor
C10	0603	1 nF	1 nF	±10%	IFA feedback capacitor
C11	0603	1 nF	1 nF	±10%	IFA feedback capacitor
C12	0805	10 pF	10 pF	±5%	DEMODO phase-shift capacitor
C15	0805	100 pF	100 pF	±5%	demodulator output low-pass capacitor, this value for data rates < 20 kbps NRZ, for higher data rates decrease the value
C16	0805	1.5 nF	1.5 nF	±10%	RSSI output low-pass capacitor
C17	0805	10 nF	10 nF	±10%	data slicer capacitor, this value for data rates > 0.8 kbps NRZ, for lower data rates increase the value
CB1 to CB5 CB7 to CB8	0603	330 pF	330 pF	±10%	de-coupling capacitor
CB6	0805	33 nF	33 nF	±10%	de-coupling capacitor
C_RO	0603	330 pF	330 pF	±5%	optional capacitor, to couple external RO signal
R1	0603	10 kΩ	10 kΩ	±5%	loop filter resistor
R2	0603	330 Ω	330 Ω	±5%	optional CERFIL output matching resistor
R4	0805	330 kΩ	330 kΩ	±5%	data slicer resistor
R5	0805	220 kΩ	220 kΩ	±5%	loading resistor
L1	0603	22 nH	0 Ω	±5%	SAW filter matching inductor from Würth-Elektronik (WE-KI series), or equivalent part
L2	0603	22 nH	0 Ω	±5%	
L3	0603	10 nH	10 nH	±5%	LNA output tank inductor from Würth-Elektronik (WE-KI series), or equivalent part
L4	0805	100 nH	100 nH	±5%	IF1 tank inductor from Würth-Elektronik (WE-KI series), or equivalent part
L5	0805	100 nH	100 nH	±5%	
XTAL	SMD 6x3.5	25.22353 MHz @ RF = 868.3 MHz	26.59706 MHz @ RF = 915 MHz	±25ppm cal. ±30ppm temp.	fundamental-mode crystal from Telcona/Horizon (HEX22 series) or equivalent part
	HC49 SMD				fundamental-mode crystal, C <sub>load</sub> = 10 pF to 15 pF, C <sub>0, max</sub> = 7 pF, R <sub>1, max</sub> = 50 Ω
SAWFIL	SMD 3x3	SAFCC868MSL0X00 (f <sub>0</sub> = 868.3 MHz)	SAFCH915MAL0N00 (f <sub>0</sub> = 915 MHz)	B <sub>3dB</sub> = 2 MHz	low-loss SAW filter from Murata or equivalent part
	SMD 3.8x3.8			B <sub>3dB</sub> = 40 MHz	
CERFIL	SMD 3.45x3.1	SFECF10M7HA00		B <sub>3dB</sub> = 180 kHz	ceramic filter from Murata, or equivalent part
CERDIS	SMD 4.5x2	CDSCB10M7GA135			ceramic discriminator from Murata, or equivalent part

2.1.3 Component Arrangement Top Side for FSK Reception

Board size is 42.7mm x 37.5mm

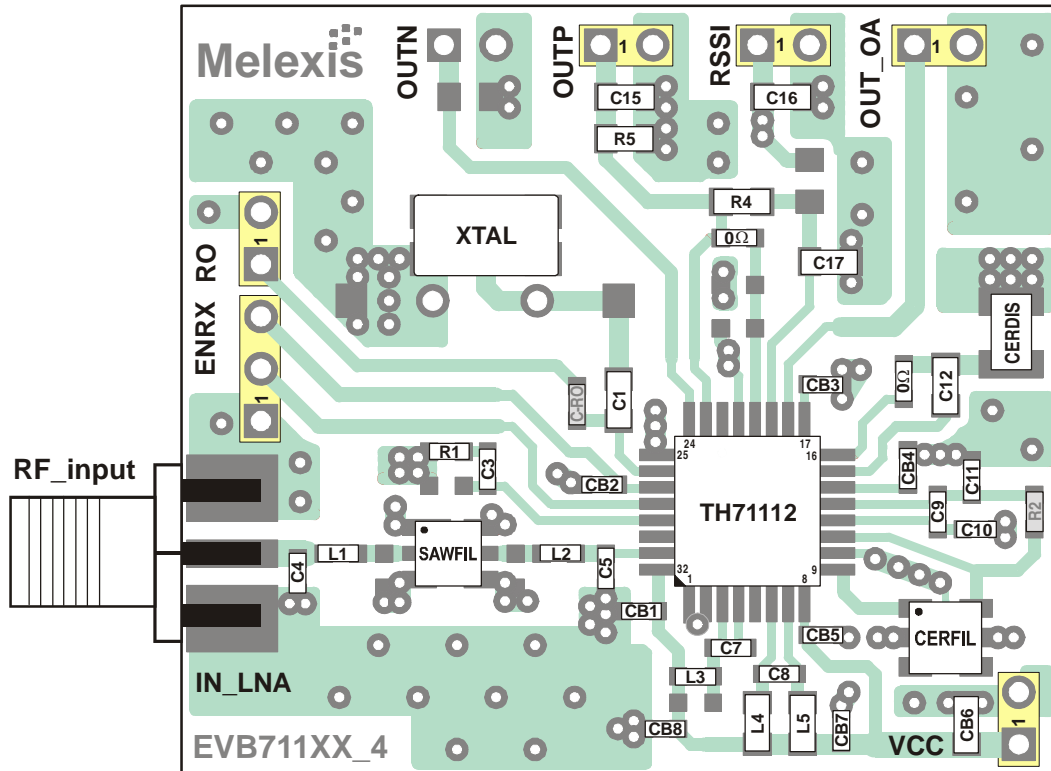

## 2.2 ASK Application Circuit

### 2.2.1 Circuit Diagram for ASK Reception

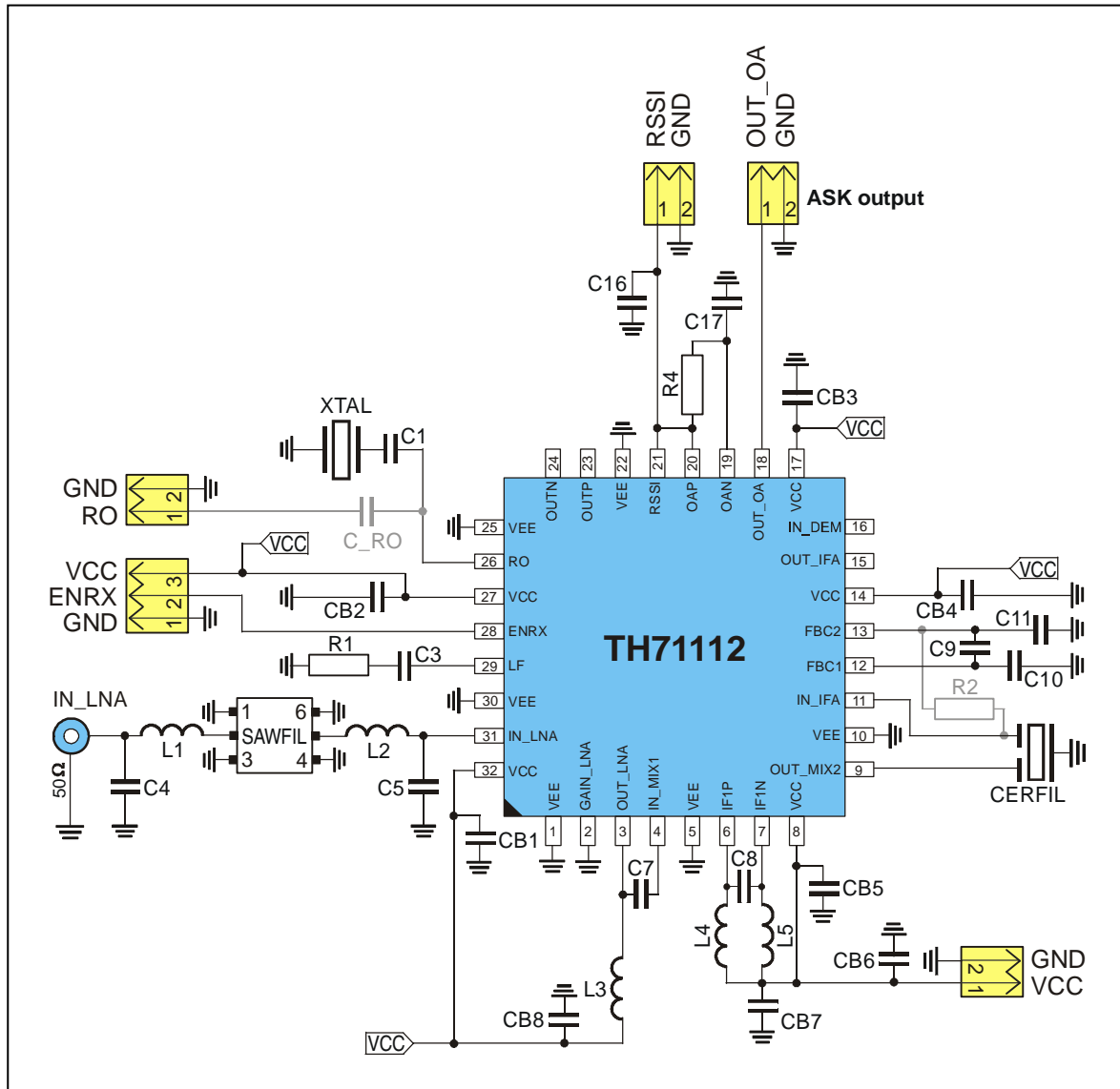

### 2.2.2 Board Component Values for ASK

Part	Size	Value @ 868.3 MHz	Value @ 915 MHz	Tolerance	Description
C1	0805	22 pF	22 pF	±5%	crystal series capacitor
C3	0603	1 nF	1 nF	±10%	loop filter capacitor
C4	0603	4,7 pF	NIP	±5%	capacitor to match SAW filter input
C5	0603	2.7 pF	NIP	±5%	capacitor to match SAW filter output
C7	0603	1.0 pF	0.68 pF	±5%	MIX1 input matching capacitor
C8	0603	22 pF	22 pF	±5%	IF1 tank capacitor
C9	0603	33 nF	33 nF	±10%	IFA feedback capacitor
C10	0603	1 nF	1 nF	±10%	IFA feedback capacitor
C11	0603	1 nF	1 nF	±10%	IFA feedback capacitor
C16	0805	1.5 nF	1.5 nF	±10%	RSSI output low-pass capacitor, this value for data rates < 10 kbps NRZ, for higher data rates decrease the value
C17	0805	10 nF	10 nF	±10%	data slicer capacitor, this value for data rates > 0.8 kbps NRZ, for lower data rates increase the value
CB1 to CB5 CB7 to CB8	0603	330 pF	330 pF	±10%	de-coupling capacitor
CB6	0805	33 nF	33 nF	±10%	de-coupling capacitor
C_RO	0603	330 pF	330 pF	±5%	optional capacitor, to couple external RO signal
R1	0603	10 kΩ	10 kΩ	±5%	loop filter resistor
R2	0603	330 Ω	330 Ω	±5%	optional CERFIL output matching resistor
R4	0805	330 kΩ	330 kΩ	±5%	data slicer resistor
L1	0603	22 nH	0 Ω	±5%	SAW filter matching inductor from Würth-Elektronik (WE-KI series), or equivalent part
L2	0603	22 nH	0 Ω	±5%	
L3	0603	10 nH	10 nH	±5%	LNA output tank inductor from Würth-Elektronik (WE-KI series), or equivalent part
L4	0805	100 nH	100 nH	±5%	IF1 tank inductor from Würth-Elektronik (WE-KI series), or equivalent part
L5	0805	100 nH	100 nH	±5%	
XTAL	SMD 6x3.5	25.22353 MHz @ RF = 868.3 MHz	26.59706 MHz @ RF = 915 MHz	±25ppm cal. ±30ppm temp.	fundamental-mode crystal from Telcona/Horizon (HEX22 series) or equivalent part
	HC49 SMD				fundamental-mode crystal, C <sub>load</sub> = 10 pF to 15 pF, C <sub>0,max</sub> = 7 pF, R <sub>1,max</sub> = 50 Ω
SAWFIL	SMD 3x3	SAFCC868MSL0X00 (f <sub>0</sub> = 868.3 MHz)	SAFCH915MALON00 (f <sub>0</sub> = 915 MHz)	B <sub>3dB</sub> = 2 MHz	low-loss SAW filters from Murata or equivalent part
	SMD 3.8x3.8			B <sub>3dB</sub> = 40 MHz	
CERFIL	SMD 3.45x3.1	SFECF10M7HA00		B <sub>3dB</sub> = 180 kHz	ceramic filter from Murata, or equivalent part

**2.2.3 Component Arrangement Top Side for ASK Reception**

Board size is 42.7mm x 37.5mm

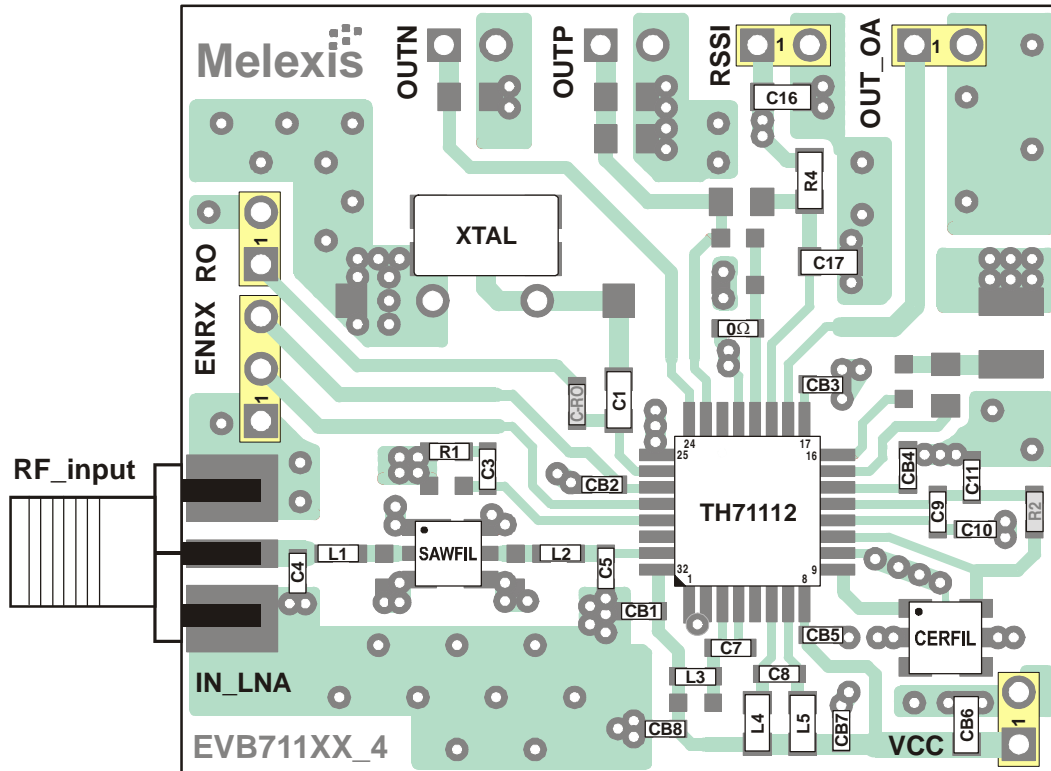

### 3 Evaluation Board Layouts

Board layout data in Gerber format is available, board size is 37.5mm x 42.7mm.

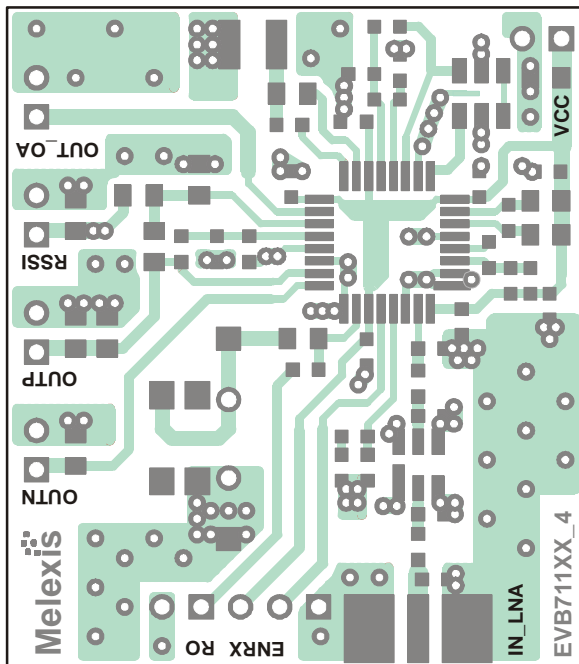

PCB top view

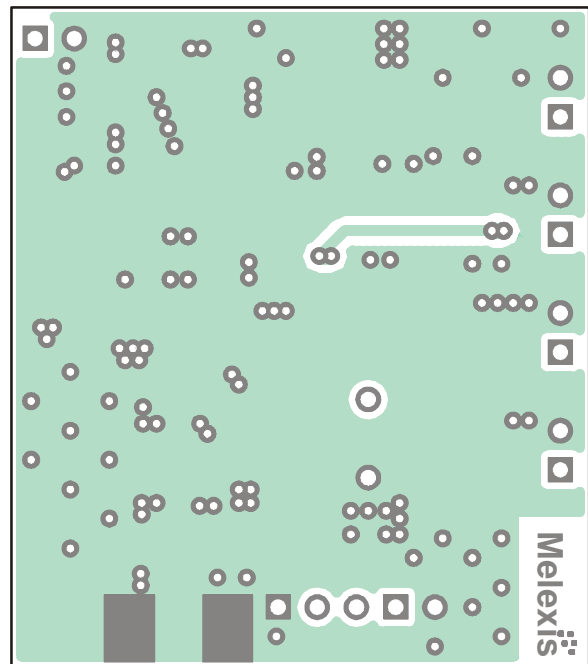

PCB bottom view

### 4 Package Description

 The device TH71112 is RoHS compliant.

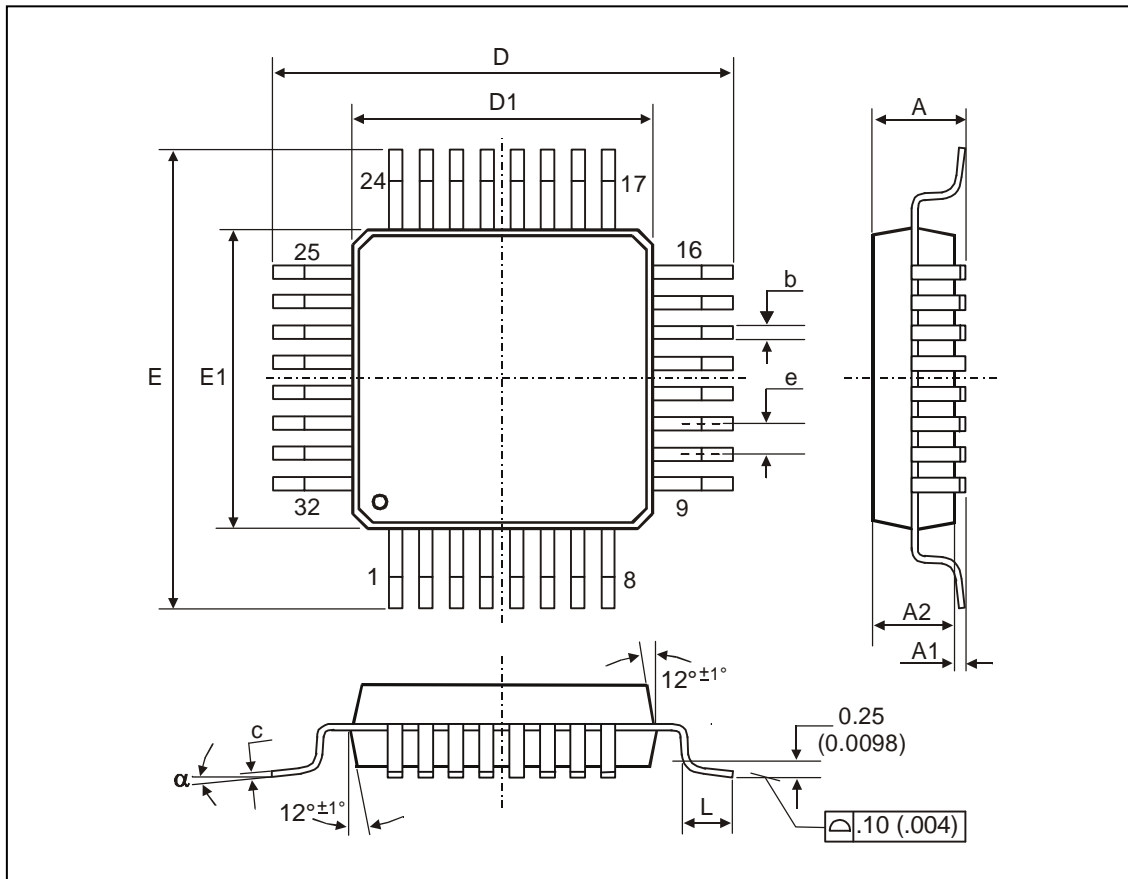

Fig. 2: LQFP32 (Low profile Quad Flat Package)

All Dimension in mm, coplanarity < 0.1mm										
	E1, D1	E, D	A	A1	A2	e	b	c	L	$\alpha$
min	7.00	9.00	1.40	0.05	1.35	0.8	0.30	0.09	0.45	0°
max			1.60	0.15	1.45		0.45	0.20	0.75	7°
All Dimension in inch, coplanarity < 0.004"										
min	0.276	0.354	0.055	0.002	0.053	0.031	0.012	0.0035	0.018	0°
max			0.063	0.006	0.057		0.018	0.0079	0.030	7°

#### 4.1 Soldering Information

- The device TH71112 is qualified for MSL3 with soldering peak temperature 260 deg C according to JEDEC J-STD-2.

## **5 Disclaimer**

- 1) The information included in this documentation is subject to Melexis intellectual and other property rights. Reproduction of information is permissible only if the information will not be altered and is accompanied by all associated conditions, limitations and notices.
  - 2) Any use of the documentation without the prior written consent of Melexis other than the one set forth in clause 1 is an unfair and deceptive business practice. Melexis is not responsible or liable for such altered documentation.
  - 3) The information furnished by Melexis in this documentation is provided 'as is'. Except as expressly warranted in any other applicable license agreement, Melexis disclaims all warranties either express, implied, statutory or otherwise including but not limited to the merchantability, fitness for a particular purpose, title and non-infringement with regard to the content of this documentation.
  - 4) Notwithstanding the fact that Melexis endeavors to take care of the concept and content of this documentation, it may include technical or factual inaccuracies or typographical errors. Melexis disclaims any responsibility in connection herewith.
  - 5) Melexis reserves the right to change the documentation, the specifications and prices at any time and without notice. Therefore, prior to designing this product into a system, it is necessary to check with Melexis for current information.
  - 6) Melexis shall not be liable to recipient or any third party for any damages, including but not limited to personal injury, property damage, loss of profits, loss of use, interrupt of business or indirect, special incidental or consequential damages, of any kind, in connection with or arising out of the furnishing, performance or use of the information in this documentation.
  - 7) The product described in this documentation is intended for use in normal commercial applications. Applications requiring operation beyond ranges specified in this documentation, unusual environmental requirements, or high reliability applications, such as military, medical life-support or life-sustaining equipment are specifically not recommended without additional processing by Melexis for each application.
  - 8) Any supply of products by Melexis will be governed by the Melexis Terms of Sale, published on [www.melexis.com](http://www.melexis.com).
- © Melexis NV. All rights reserved.

---

For the latest version of this document, go to our website at:

[www.melexis.com](http://www.melexis.com)

Or for additional information contact Melexis Direct:

Europe, Africa:  
Phone: +32 1367 0495  
E-mail: [sales\\_europe@melexis.com](mailto:sales_europe@melexis.com)

Americas:  
Phone: +1 603 223 2362  
E-mail: [sales\\_usa@melexis.com](mailto:sales_usa@melexis.com)

Asia:  
Phone: +32 1367 0495  
E-mail: [sales\\_asia@melexis.com](mailto:sales_asia@melexis.com)

ISO/TS 16949 and ISO14001 Certified