

Features



Microcontroller: MLX16-FX RISC CPU

- 16 bit RISC CPU with 20DMIPS and Power-Saving-Modes
- Co-processor for fast multiplication and division
- Flash and EEPROM memory with EEC
- In-circuit debug and emulation

Supported bus interfaces:

- LIN-Interface with integrated LIN transceiver supporting LIN 2.x, certified LIN protocol software provided by Melexis
- In-Module-Programming (Flash and EE) via pin LIN using a special Melexis fast protocol
- PWM-Interface
- Full duplex SPI, Master/Slave, double-buffered, speed programmable. DMA access. Flash and EEPROM programming also possible via SPI.

TruSense Motor Control Technology

- Patented algorithms for sensor-less 3-phase sine and trapezoidal motor control
- Phase voltage integration filter for BEMF voltage sensing at lowest speeds
- Position dependent phase inductance sensing via shunt current measurements at stand still and low to medium speeds
- Support of Star and Delta based motor configurations without the need for center star point
- Support of 3-phase switched reluctance motor control

Voltage Regulator

- Direct powered from 12V board net with low voltage detection
- Operating voltage $V_S = 5V$ to 18V
- Internal voltage regulator with possibility to use external regulator transistor
- Very low standby current, < 30 μ A in sleep mode, wake-up possible via LIN or local sources

Pre-Driver

- Pre-driver (~25 Ω R_{dson}) for all 3 N-FET half bridges with programmable Inter-Lock-Delay and slope control for optimal EMC and thermal performance during power N-FET switching
- Monitoring of Drain-Source voltages of the N-FETs

Periphery

- 4 independent 16 bit timer modules with capture and compare, and additional software timer
- 3 programmable 12 bit PWM units with programmable frequencies
- 10 bit ADC converter (2 μ s conversion time) and DMA access
- On-chip temperature sensor with $\pm 10K$ accuracy
- System-clock-independent fully integrated watchdog
- 32 MHz $\pm 5\%$ internal RC oscillator with PLL
- Optional crystal oscillator
- Load dump and brown out interrupt function
- Integrated shunt current amplifier with programmable gain

Applications

The MLX81205/07/10/15 controls BLDC motors via external FET transistors for:

- Oil-, water-, fuel-pumps
- Blowers, compressors
- Positioning actuators

Family Concept

	MLX81205	MLX81207	MLX81210	MLX81215
Flash Memory [kByte]	32	32	32	64
RAM [kByte]	4	4	8	8
EEPROM [Byte]	384	384	384	384
Package	QFN32	QFN48 TQFP EP 48	QFN48 TQFP EP 48	QFN48 TQFP EP 48
Support of active high side reverse polarity protection	No	Yes	Yes	Yes
Current shunt measurement possibility	High side	High side	Low side, High side	Low side, High side
UART	Yes	Yes	Yes	Yes
SPI	No	Yes	Yes	Yes
Support of sensor based BLDC motor control	No	Yes	Yes	Yes
Support of Switched Reluctance (SR) motor control	No	No	No	Yes
5V Regulator support for 5V external supplies (CAN support)	No	No	Yes	Yes
Bonded pins in package	32	37	48	48
Pin compatibility			MLX81210 and MLX81215 are pin compatible	

Table 1 – Family Options

Ordering Information

Order Code ^[1]	Temp. Range	Package	Delivery	Remark
MLX81205 LLQ-xAA-000-TU	-40 - 150 °C	QFN32 5x5	Tube	
MLX81205 LLQ-xAA-000-RE	-40 - 150 °C	QFN32 5x5	Reel	
MLX81207 LLQ-xAA-000-TU	-40 - 150 °C	QFN48 7x7	Tube	
MLX81207 LLQ-xAA-000-RE	-40 - 150 °C	QFN48 7x7	Reel	
MLX81207 LPF-xAA-000-TR	-40 - 150 °C	TQFP EP 48 7x7	Tray	
MLX81207 LPF-xAA-000-RE	-40 - 150 °C	TQFP EP 48 7x7	Reel	
MLX81210 LLQ-xAA-000-TU	-40 - 150 °C	QFN48 7x7	Tube	
MLX81210 LLQ-xAA-000-RE	-40 - 150 °C	QFN48 7x7	Reel	
MLX81210 LPF-xAA-000-TR	-40 - 150 °C	TQFP EP 48 7x7	Tray	
MLX81210 LPF-xAA-000-RE	-40 - 150 °C	TQFP EP 48 7x7	Reel	
MLX81215 LLQ-xAA-000-TU	-40 - 150 °C	QFN48 7x7	Tube	
MLX81215 LLQ-xAA-000-RE	-40 - 150 °C	QFN48 7x7	Reel	
MLX81215 LPF-xAA-000-TR	-40 - 150 °C	TQFP EP 48 7x7	Tray	
MLX81215 LPF-xAA-000-RE	-40 - 150 °C	TQFP EP 48 7x7	Reel	

Table 2 – Ordering Information

^[1]. See Marking/Order Code.

Contents

1. FUNCTIONAL DIAGRAM	5
2. PIN DESCRIPTION	6
3. ELECTRICAL CHARACTERISTICS.....	7
3.1 OPERATING CONDITIONS	7
3.2 ABSOLUTE MAXIMUM RATINGS	7
4. APPLICATION EXAMPLES.....	8
4.1 SENSOR-LESS BLDC MOTOR CONTROL ON THE LIN-BUS OR VIA PWM-INTERFACE WITH REVERSE POLARITY PROTECTION AND CURRENT SENSING.....	8
4.2 SENSOR-LESS BLDC MOTOR CONTROL ON THE LIN-BUS OR VIA PWM-INTERFACE WITH REVERSE POLARITY PROTECTION IN THE HIGH SIDE PATH.....	10
4.3 SENSOR BASED BLDC MOTOR CONTROL.....	11
4.4 SENSOR-LESS BLDC MOTOR CONTROL WITH ABSOLUTE POSITION SENSING.....	12
4.5 SENSOR-LESS BLDC MOTOR CONTROL VIA A CAN-BUS-INTERFACE.....	13
5. MECHANICAL SPECIFICATION.....	14
5.1 QFN.....	14
5.1.1. QFN32 5x5 (32 leads).....	14
5.1.2. QFN48 7x7 (48 leads).....	14
5.2 TQFP EP 48 7x7 (48 LEADS).....	15
6. MARKING/ORDER CODE	16
6.1 MARKING MLX81205/07/10/15.....	16
6.2 ORDER CODE MLX81205/07/10/15.....	16
7. ASSEMBLY INFORMATION.....	17
8. DISCLAIMER.....	18

1. Functional Diagram

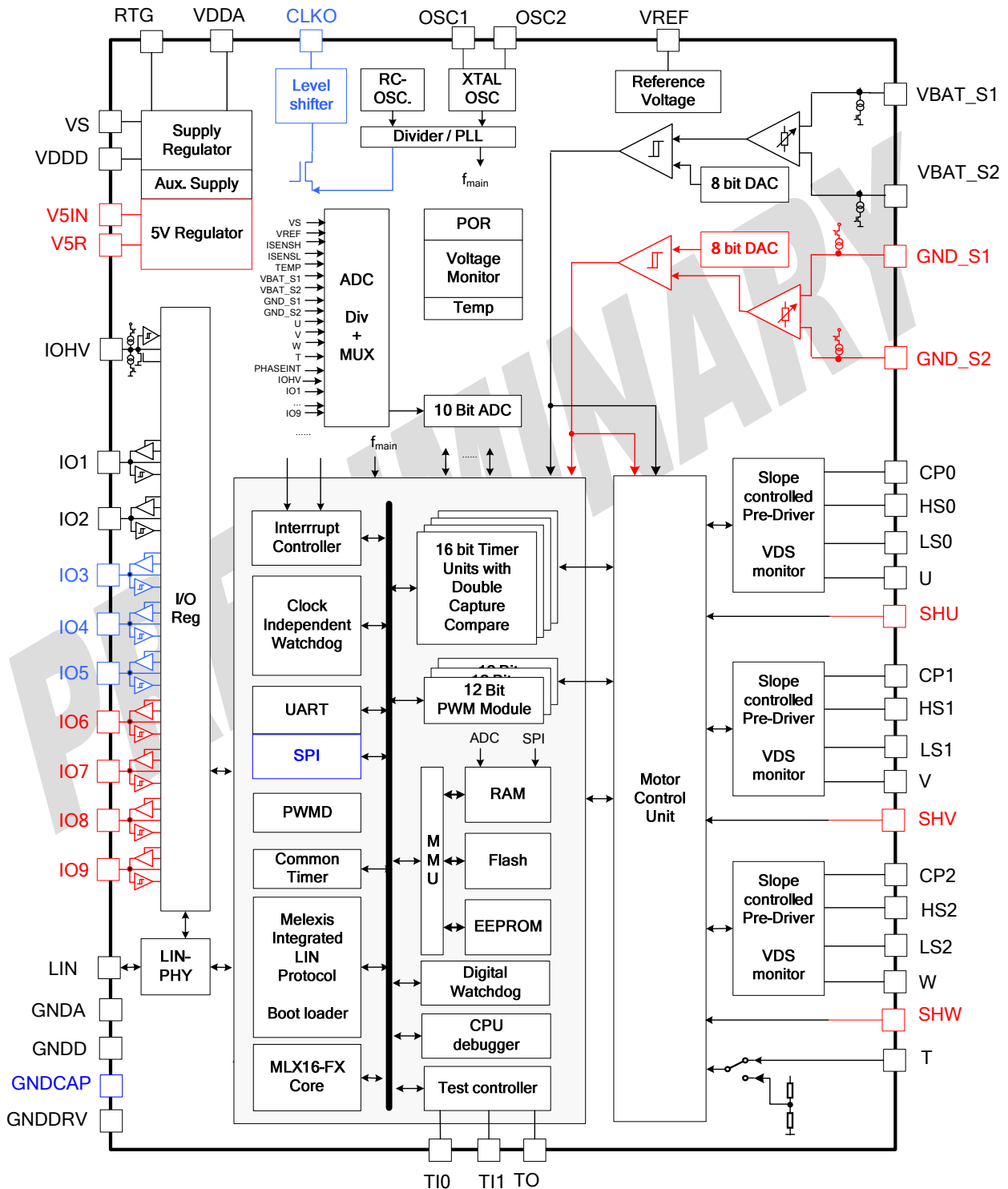

Figure 1 - Block Diagram

Black: common for all versions,

Blue: additional pins / functionality for MLX81207,

Blue + red: additional pins / functionality for MLX81210 / MLX81215

2. Pin Description

Name	Type	Function	MLX81205	MLX81207	MLX81210	MLX81215
VS	P	Battery Supply	X	X	X	X
RTG	O	3.3V External MOS Gate Control	X	X	X	X
VDDA	P	3.3V Supply	X	X	X	X
V5R	P	5V Regulator Output for external NFET			X	X
V5IN	I	5V Regulator Input			X	X
VDDD	P	1.8V Regulator output	X	X	X	X
GNDD	GND	Digital ground	X	X	X	X
GNDCAP	GND	Digital ground		X	X	X
GNDDRV	GND	Driver ground	X	X	X	X
GND A	GND	Analog ground	X	X	X	X
LIN	HVIO	Connection to LIN bus or PWM interface	X	X	X	X
IOHV	HVIO	General purpose IO pin	X	X	X	X
TI0	I	Test input, debug interface	X	X	X	X
TI1	I	Test input, debug interface	X	X	X	X
TO	O	Test output, debug interface	X	X	X	X
OSC1	I	Quarz interface input	X	X	X	X
OSC2	O	Quarz interface ouput	X	X	X	X
IO1	LVIO	General purpose IO pin (Low voltage 3.3V)	X	X	X	X
IO2	LVIO	General purpose IO pin (Low voltage 3.3V)	X	X	X	X
IO3	LVIO	General purpose IO pin (Low voltage 3.3V)		X	X	X
IO4	LVIO	General purpose IO pin (Low voltage 3.3V)		X	X	X
IO5	LVIO	General purpose IO pin (Low voltage 3.3V)		X	X	X
IO6	LVIO	General purpose IO pin (Low voltage 3.3V)			X	X
IO7	LVIO	General purpose IO pin (Low voltage 3.3V)			X	X
IO8	LVIO	General purpose IO pin (Low voltage 3.3V)			X	X
IO9	LVIO	General purpose IO pin (Low voltage 3.3V)			X	X
CLKO	HVO	Switchable 250kHz clock output to VREF level		X	X	X
SHU	HVI	Phase U input to BEMF sensing blocks			X	X
SHV	HVI	Phase V input to BEMF sensing blocks			X	X
SHW	HVI	Phase W input to BEMF sensing blocks			X	X
T	HVI	Reference input to BEMF sensing blocks	X	X	X	X
VREF	P	Clamped 8V or 12V ref. voltage for bootstrap	X	X	X	X
CP2	HVIO	High side bootstrap capacitor driver 2	X	X	X	X
HS2	HVIO	N-FET high side gate driver 2	X	X	X	X
W	HVI	Phase W input to HS2 buffer and BEMF sensing blocks	X	X	X	X
LS2	HVO	N-FET low side gate driver 2	X	X	X	X
CP1	HVIO	High side bootstrap capacitor driver 1	X	X	X	X
HS1	HVIO	N-FET high side gate driver 1	X	X	X	X
V	HVI	Phase V input to HS1 buffer and BEMF sensing blocks	X	X	X	X
LS1	HVO	N-FET low side gate driver 1	X	X	X	X
CP0	HVIO	High side bootstrap capacitor driver 0	X	X	X	X
HS0	HVIO	N-FET high side gate driver 0	X	X	X	X
U	HVI	Phase U input to HS0 buffer and BEMF sensing blocks	X	X	X	X
LS0	HVO	N-FET low side gate driver 0	X	X	X	X
VBAT_S1	HVI	VS high side input for current sensing	X	X	X	X
VBAT_S2	HVI	VS low side input for current sensing	X	X	X	X

GND_S1	LVI	GND high side input for current sensing			X	X
GND_S2	LVI	GND low side input for current sensing			X	X
Pin count			32	37	48	48

Table 3 - Pin Description MLX81205 / MLX81207 / MLX81210 / MLX81215

3. Electrical Characteristics

All voltages are referenced to ground (GND). Positive currents flow into the IC. The absolute maximum ratings given in the table below are limiting values that do not lead to a permanent damage of the device but exceeding any of these limits may do so. Long term exposure to limiting values may affect the reliability of the device. Reliable operation of the MLX81205/07/10/15 is only specified within the limits shown in Operating conditions.

3.1 Operating Conditions

Parameter	Symbol	Min	Max	Unit
IC supply voltage	V_s	5	18	V
Operating ambient temperature	T_{amb}	-40	+150 ^[1]	°C

Table 4 - Operating Conditions

^[1] Target temperature specification after qualification. With temperature applications at $T_A > 125^\circ\text{C}$ a reduction of chip internal power dissipation with external supply transistor is mandatory. The extended temperature range is only allowed for a limited period of time, customer's mission profile has to be agreed by Melexis as a mandatory part of the Part Submission Warrant.

3.2 Absolute Maximum Ratings

Parameter	Symbol	Condition	Min	Max	Unit
IC supply voltage	VS	T = 2 min	-0.3	28	V
		T < 500 ms		45	
Maximum reverse current into any pin			-10	+10	mA
Maximum sum of reverse currents into all pins				+10	mA
DC voltage on LVIO pins, OSC<2:1>, GND_S<2:1>			-0.3	VDDA+0.3	V
DC voltage on HV I/O pin, V5R pin			-0.3	VS+0.3	V
DC voltage on drivers supply pin VREF			-0.3	18	V
DC voltage on drivers control pins (CLKO, LS<2:0>)			-0.3	VREF+0.3	V
DC voltage on drivers CP<2:0>, HS<2:0> pins			-0.3	VS + VREF	V
DC voltage on phases related pins (U, V, W, SHU, SHV, SHW, T, VBAT_S<2:1>)			-0.3	VS+1.5	V
ESD capability of pin LIN	ESD _{BUSHB}	Human body model, equivalent to discharge 100pF with 1.5kΩ,	-6	+6	kV
ESD capability of any other pins	ESD _{HB}	Human body model, equivalent to discharge 100pF with 1.5kΩ,	-2	+2	kV
Maximum latch-up free current at any Pin	I _{LATCH}		-250	+250	mA
Junction temperature ^[1]	T_{vj}			+155	°C
Storage temperature	T_{stg}		-55	+150	°C
R _{thjc} QFN32	R _{thjc}			10	K / W
R _{thjc} QFN48				5	K / W
R _{thjc} TQFP48				5.5	K / W

Table 5 - Absolute Maximum Ratings

^[1] Target temperature specification after qualification. With temperature applications at $T_A > 125^\circ\text{C}$ a reduction of chip internal power dissipation with external supply transistor is mandatory. The extended temperature range is only allowed for a limited period of time, customer's mission profile has to be agreed by Melexis as a mandatory part of the Part Submission Warrant.

4. Application Examples

The following sections show typical application examples^[1].

4.1 Sensor-less BLDC Motor Control on the LIN-Bus or via PWM-Interface with reverse polarity protection and current sensing

In the sample application of Figure 2, the MLX81205 can realize the sensor-less driving of a BLDC motor via three external power N-FET half bridges with only a few external components. The high side N-FET driving is done with a bootstrap output stage. Reverse polarity protection of the bridge is realized with an external power FET in the ground path. An external temperature sensor is connected to the 10 bit ADC via pin IO1. The integrated watchdog with a dedicated separate RC-oscillator is monitoring application integrity. The communication interface could be LIN or a PWM interface. The pin LIN can also be used as wake-up source and to program the Flash memory.

The motor currents are measured by a shunt resistor in the high side path. In case the current exceeds the programmed threshold, the bridge can be switched off automatically and / or a software interrupt can be generated. The motor current can also be measured by the 10-bit ADC converter.

The patented Melexis TruSense technology combines two methods to determine the rotor position:

- The measurement of the induced BEMF voltage at medium and high speeds.
- The measurement of position dependent coil inductance variations at stand-still and low speeds.

As a result TruSense allows operation of the motor in the widest dynamic speed range. The motor can be driven with block, trapezoidal or sine-wave currents. The motor start-up can be made independent of the load conditions according to the application requirements.

In this example application the motor star point is not available. It is modeled with external resistors from the motor phases and connected to T input. Alternatively an artificial IC internal reference point can be chosen as shown in the block diagram of the MLX81205/07/10/15.

^[1] The application examples are principal application schematics only. The details need to be worked out for each application schematic separately, depending on the application requirements.

4.2 Sensor-less BLDC Motor Control on the LIN-Bus or via PWM-Interface with reverse polarity protection in the high side path

In the sample application of Figure 3, the MLX81207 has been selected in order to benefit from the external high side reverse polarity protection possibility compared to the application shown in section 4.1. All other remarks from the previous application example remain valid.



Figure 3 – Typical Sensor-less BLDC Motor Control Application Example with MLX81207

4.3 Sensor based BLDC Motor Control

In the sample application of, Figure 4, the MLX81207 can realize the driving of a BLDC motor with three Hall sensors. An external P-FET is used to derive the 3.3V supply with a higher current capability in order to bring power consumption outside the MLX81207.

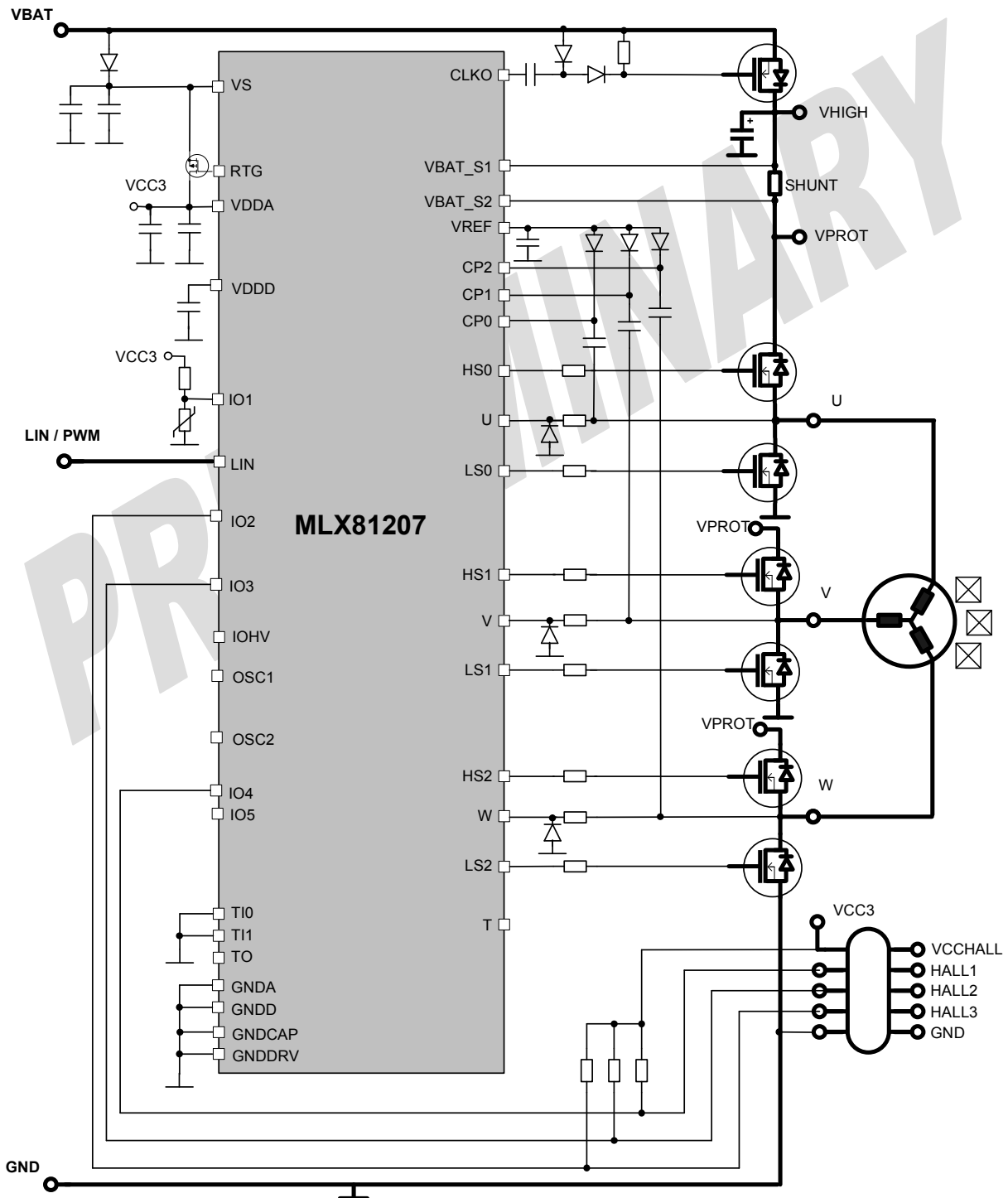

Figure 4 – Typical Sensor based BLDC Motor Control Application Example with MLX81207

4.4 Sensor-less BLDC Motor Control with absolute position sensing

In the sample application of Figure 5, the MLX81210 is working with an absolute position sensor in order to measure the position of the gear shaft in throttle valve application systems or any other similar applications, where absolute precise position sensing is requested.

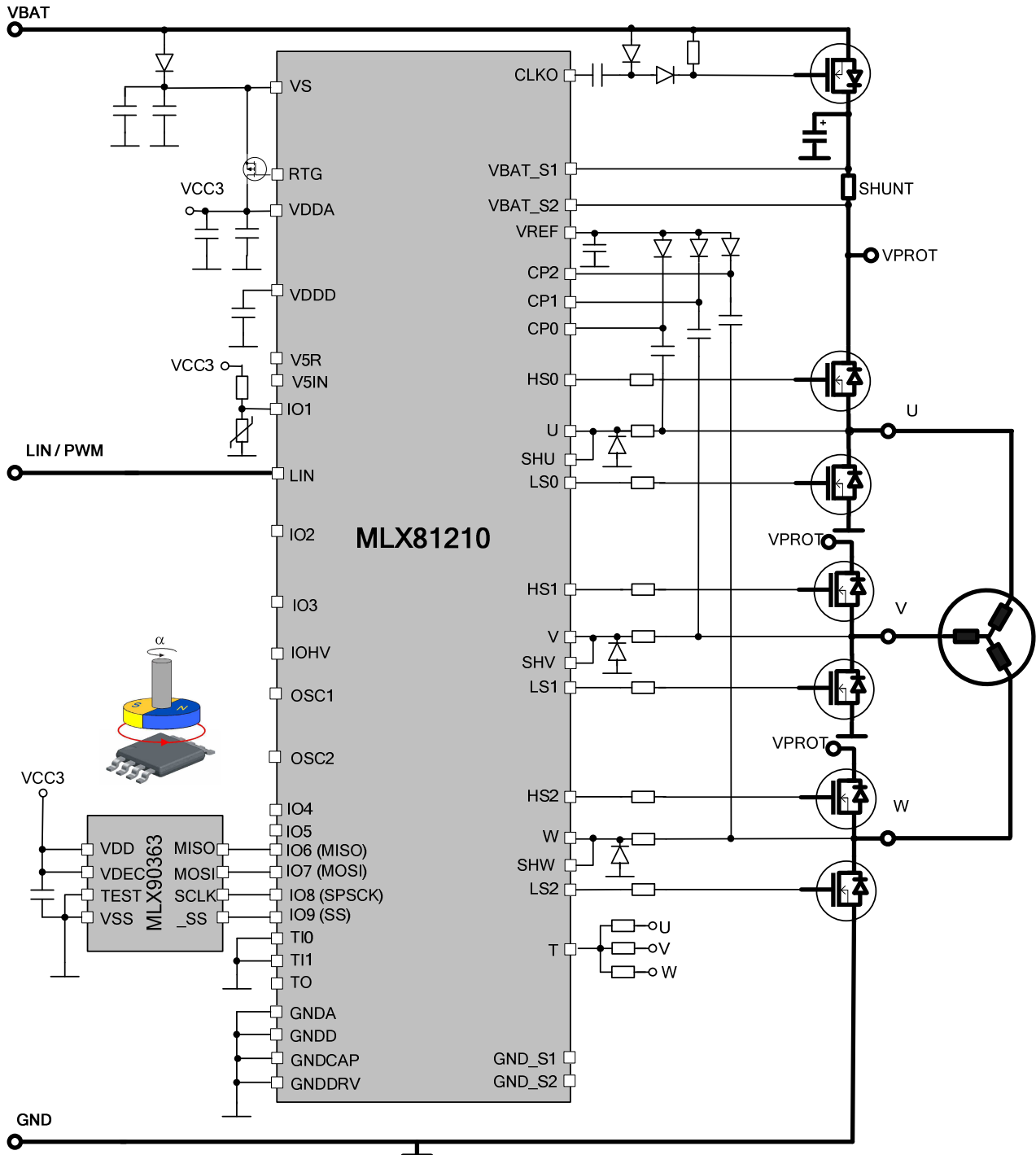

Figure 5 – Typical Sensor-less BLDC Motor Control Application Example with MLX81210 and Triaxis® absolute position sensing

4.5 Sensor-less BLDC Motor Control via a CAN-Bus-Interface

In this sample application the MLX81215 can realize the sensor-less driving of a BLDC motor via a CAN-Bus Interface. System wake-up on CAN-bus traffic is possible. The 5V and a 3.3V voltage supply needed for the CAN-Bus, is generated via external N-FET control in order to limit the power dissipation in the package.

The motor current can be monitored via shunt resistors in the ground and battery path in case the application requests a double side monitoring for security reasons.

Application programming on module level via the CAN-Bus is supported by the SPI-Interface.

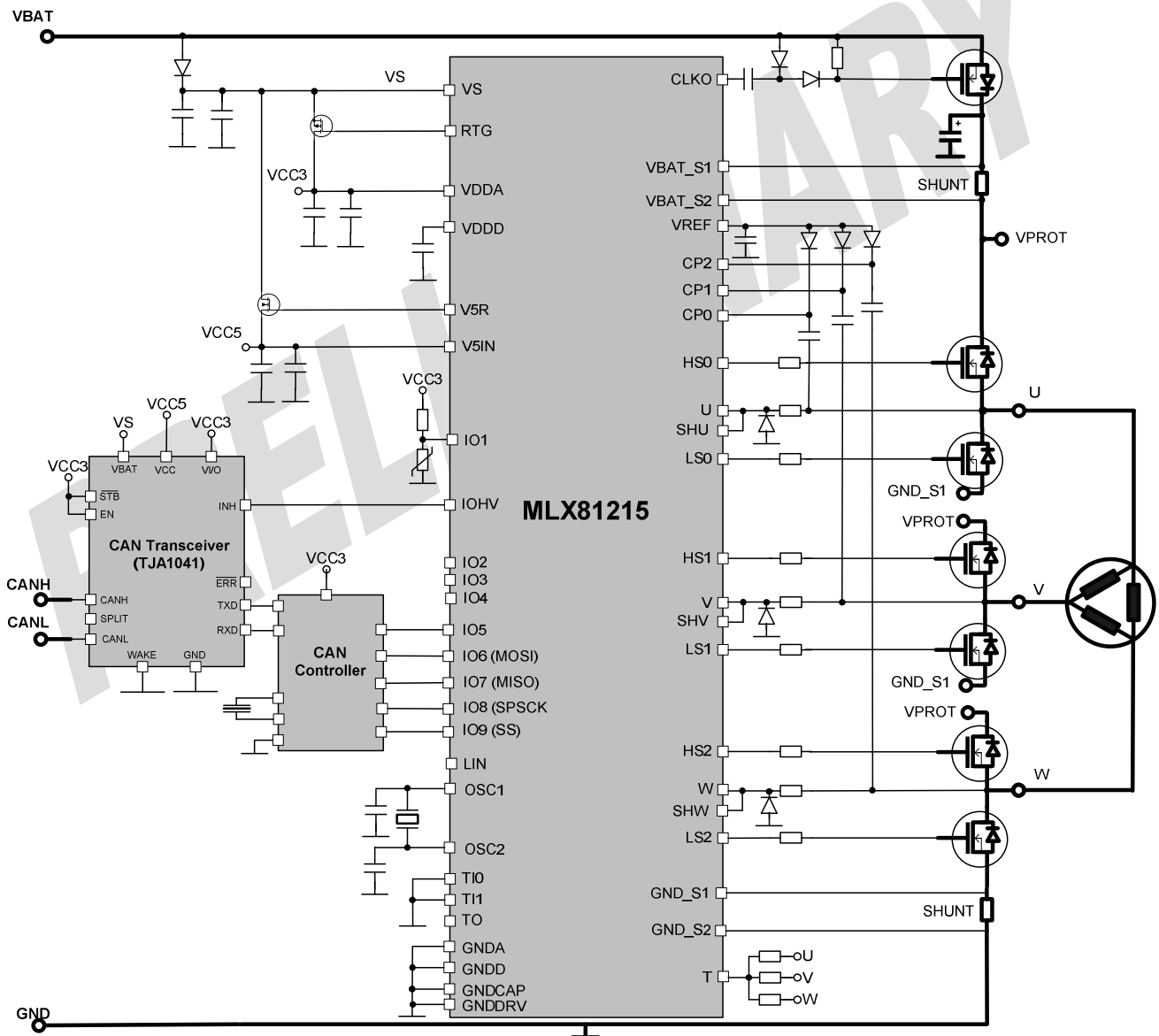

Figure 6 – Typical BLDC Motor Control Application Example on the CAN-Bus with MLX81215

5. Mechanical Specification

5.1 QFN

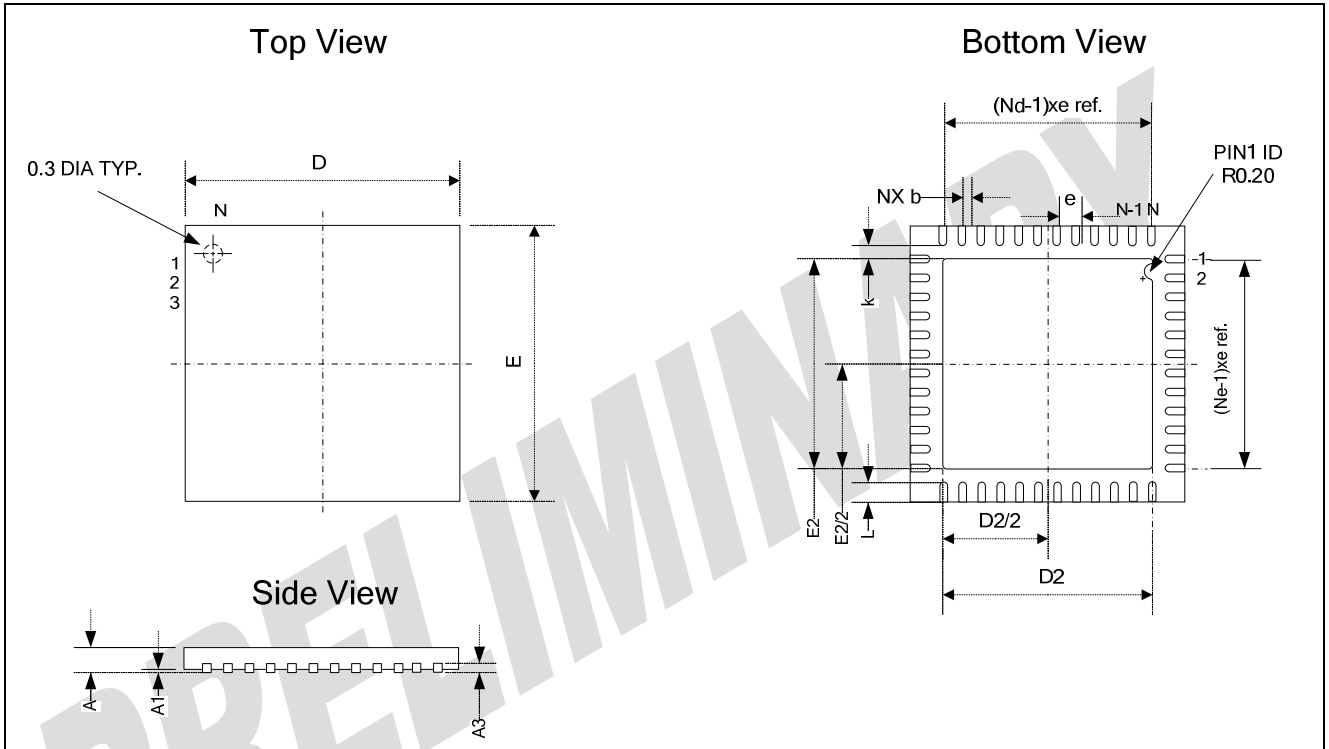

Figure 7 – QFN Drawing

5.1.1. QFN32 5x5 (32 leads)

Symbol [1][2]	A	A1	A3	b	D	D2	E	E2	e	L	N [3]	ND [4]	NE [4]			
QFN32	Min	0.80	0.00	0.20	5.00	3.50	5.00	3.50	0.50	0.35	32	8	8			
	Nom	0.85	0.02											0.25	3.60	3.60
	Max	0.90	0.05											0.30	3.70	3.70

Table 6 – QFN32 5x5 Package Dimensions

5.1.2. QFN48 7x7 (48 leads)

Symbol [1][2]	A	A1	A3	b	D	D2	E	E2	e	L	N [3]	ND [4]	NE [4]			
QFN48	Min	0.80	0	0.20	7.00	5.00	7.00	5.00	0.50	0.45	48	12	12			
	Nom	0.85	0.02											0.25	5.10	5.10
	Max	0.90	0.05											0.30	5.20	5.20

Table 7 - QFN48 7x7 Package Dimensions

[1] Dimensions and tolerances conform to ASME Y14.5M-1994
 [2] All dimensions are in Millimeters. All angels are in degrees
 [3] N is the total number of terminals
 [4] ND and NE refer to the number of terminals on each D and E side respectively

5.2 TQFP EP 48 7x7 (48 leads)

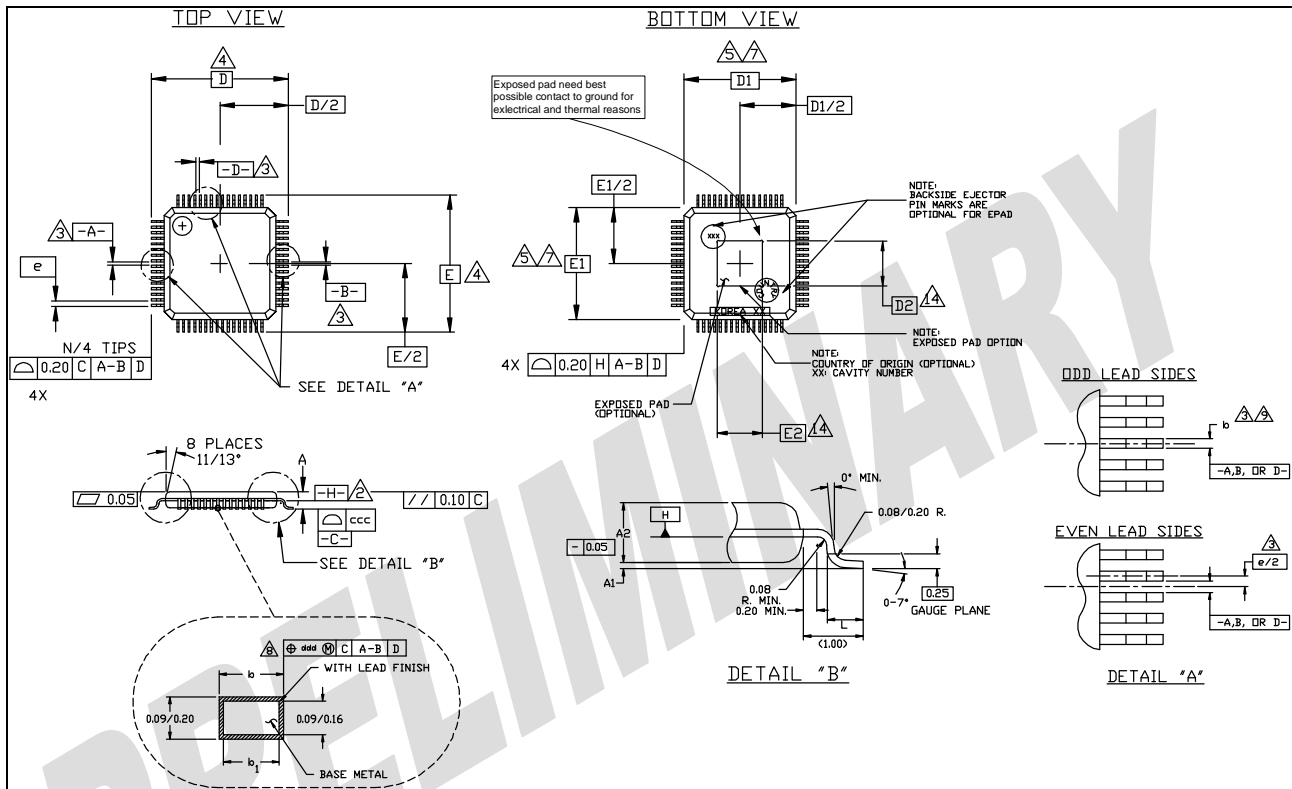

Figure 8 – TQFP EP 7x7 Drawing

	A	A1	A2	b	b1	D	D1	D2	E	E1	E2	e	L	N	Ccc	ddd
Min	-	0.05	0.95	0.17	0.17	9.00	7.00	4.00	9.00	7.00	4.00	0.50	0.45	48	-	-
Nom	-	-	1.00	0.22	0.20								0.60		-	-
Max	1.20	0.15	1.05	0.27	0.23								0.75		0.08	0.08

Table 8 – TQFP EP 7x7 Package Dimensions

Notes:

- All Dimensioning and Tolerances conform to ASME Y14.5M-1994,
- Datum Plane [-|-] located at Mould Parting Line and coincident with Lead, where Lead exists, plastic body at bottom of parting line.
- Datum [A-B] and [-D-] to be determined at centerline between leads where leads exist, plastic body at datum plane [-|-]
- To be determined at seating plane [-C-]
- Dimensions D1 and E1 do not include Mould protrusion. Dimensions D1 and E1 do not include mould protrusion. Allowable mould protrusion is 0.254 mm on D1 and E1 dimensions.
- 'N' is the total number of terminals
- These dimensions to be determined at datum plane [-|-]
- Package top dimensions are smaller than bottom dimensions and top of package will not overhang bottom of package.
- Dimension b does not include dam bar protrusion, allowable dam bar protrusion shall be 0.08mm total in excess of the "b" dimension at maximum material condition, dam bar can not be located on the lower radius of the foot.
- Controlling dimension millimeter.
- Maximum allowable die thickness to be assembled in this package family is 0.38mm
- This outline conforms to JEDEC publication 95 Registration MS-026, Variation ABA, ABC & ABD.
- A1 is defined as the distance from the seating plane to the lowest point of the package body.
- Dimension D2 and E2 represent the size of the exposed pad. The actual dimensions are specified on the bonding diagram, and are independent from die size.
- Exposed pad shall be coplanar with bottom of package within 0.05.

6. Marking/Order Code

6.1 Marking MLX81205/07/10/15

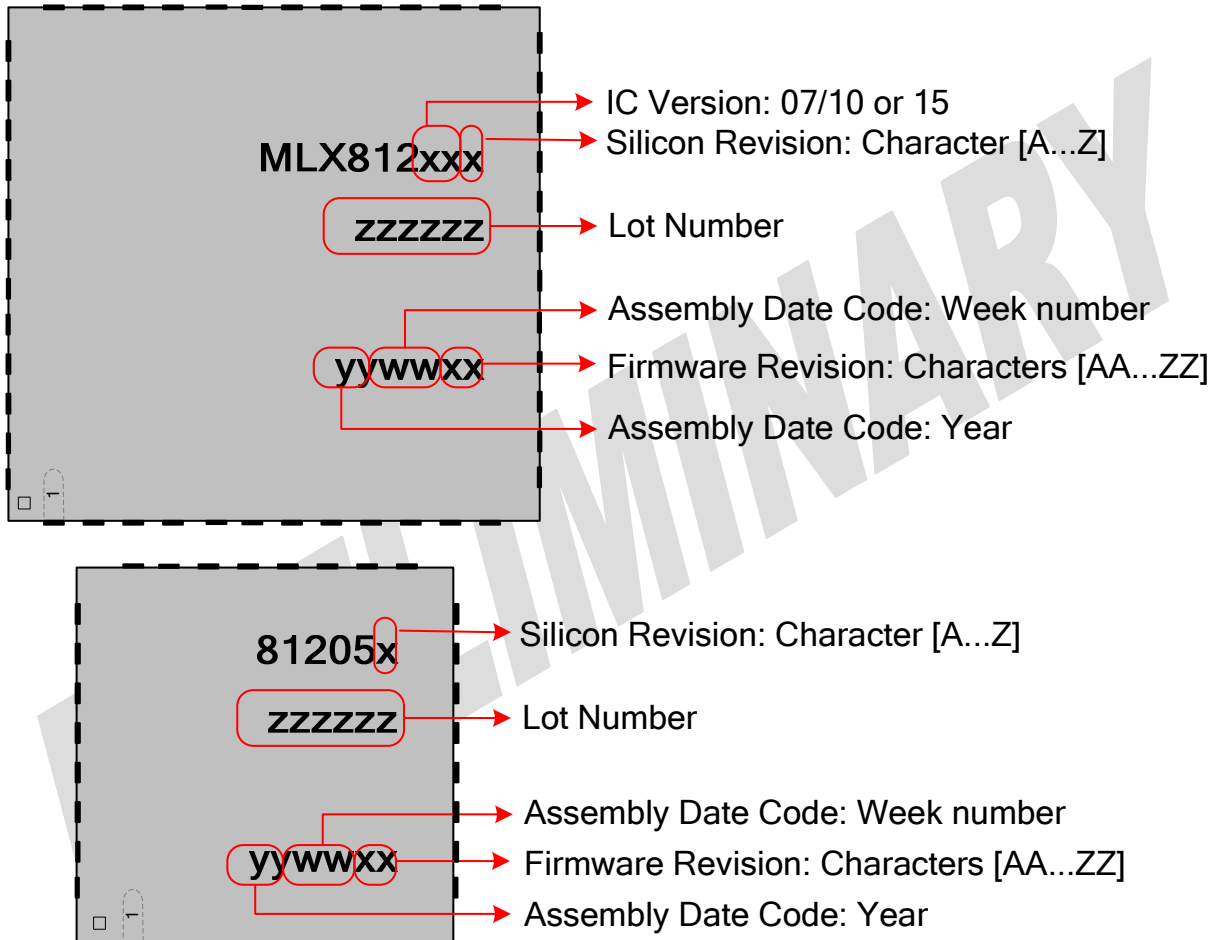

6.2 Order Code MLX81205/07/10/15

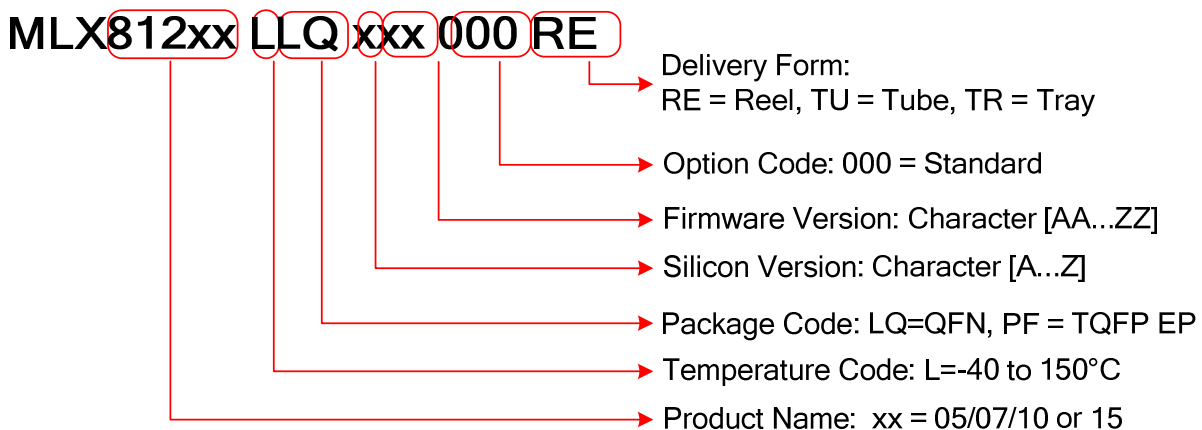

7. Assembly Information

This Melexis device is classified and qualified regarding soldering technology, solder ability and moisture sensitivity level, as defined in this specification, according to following test methods:

- IPC/JEDEC J-STD-020
Moisture/Reflow Sensitivity Classification For No hermetic Solid State Surface Mount Devices (classification reflow profiles according to table 5-2)
- EIA/JEDEC JESD22-A113
Preconditioning of No hermetic Surface Mount Devices Prior to Reliability Testing (Reflow profiles according to table 2)
- CECC00802
Standard Method For The specification of Surface Mounting Components (SMD's) of Assessed Quality
- EIA/JEDEC JESD22-B106
Resistance to soldering temperature for through-hole mounted devices
- EN60749-15
Resistance to soldering temperature for through-hole mounted devices
- MIL 883 Method 2003 / EIA/JEDEC JESD22-B102
Solder ability

For all soldering technologies deviating from above mentioned standard conditions (regarding peak temperature, temperature gradient, temperature profile etc) additional classification and qualification tests have to be agreed upon with Melexis. The application of Wave Soldering for SMD's is allowed only after consulting Melexis regarding assurance of adhesive strength between device and board.

Based on Melexis commitment to environmental responsibility, European legislation (Directive on the restriction of the use of certain hazardous substances, RoHS) and customer requests, Melexis has installed a roadmap to qualify their package families for lead free processes also. Various lead free generic qualifications are running, current results on request.

For more information on Melexis lead free statement see quality page at our website:
<http://www.melexis.com/html/pdf/MLXleadfree-statement.pdf>

8. Disclaimer

The product abstract just provides an overview of the described devices. Please consult the complete product specification/datasheet in its latest revision for any detailed information.

Devices sold by Melexis are covered by the warranty and patent indemnification provisions appearing in its Term of Sale. Melexis makes no warranty, express, statutory, implied, or by description regarding the information set forth herein or regarding the freedom of the described devices from patent infringement. Melexis reserves the right to change specifications and prices at any time and without notice. Therefore, prior to designing this product into a system, it is necessary to check with Melexis for current information. This product is intended for use in normal commercial applications. Applications requiring extended temperature range, unusual environmental requirements, or high reliability applications, such as military, medical life-support or life-sustaining equipment are specifically not recommended without additional processing by Melexis for each application.

The information furnished by Melexis is believed to be correct and accurate. However, Melexis shall not be liable to recipient or any third party for any damages, including but not limited to personal injury, property damage, loss of profits, loss of use, interrupt of business or indirect, special incidental or consequential damages, of any kind, in connection with or arising out of the furnishing, performance or use of the technical data herein. No obligation or liability to recipient or any third party shall arise or flow out of Melexis' rendering of technical or other services.

© Melexis NV. All rights reserved

PRELIMINARY DRAFT

For the latest version of this document, go to our website at
www.melexis.com

Or for additional information contact Melexis Direct:

Europe, Africa, Asia:

Phone: +32 1367 0495
E-mail: sales_europe@melexis.com

America:

Phone: +1 248 306 5400
E-mail: sales_usa@melexis.com

ISO/TS16949 and ISO14001 Certified