



NTC thermistors for temperature sensing and compensation

Leaded NTC thermistors,
lead spacing 2.5 mm

Series/Type: B57964S
Date: February 2012

Applications

- Temperature measurement and compensation

Features

- Short response time
- High measuring accuracy
- Epoxy resin encapsulation
- Improved resistance to humidity
- Insulated leads of silver-plated nickel wire, AWG 26 (black)
- Lead spacing 2.5 mm

Options

- Non-standard lead lengths
- AWG 30 on request

Delivery mode

Bulk (standard), cardboard tape available on request

General technical data

Climatic category	(IEC 60068-1)		55/155/56	
Max. power	(at 25 °C)	P_{25}	60	mW
Resistance tolerance		DR_R/R_R	$\pm 1, \pm 3, \pm 5$	%
Rated temperature		T_R	25	°C
Dissipation factor	(in air)	d_{th}	approx. 1.6	mW/K
Thermal cooling time constant	(in air)	t_c	approx. 16	s
Heat capacity		C_{th}	approx. 26	mJ/K

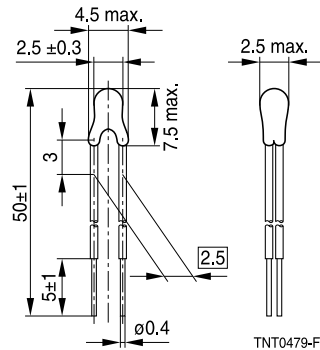
Dimensional drawing

Dimensions in mm

Approx. weight 60 mg

Electrical specification and ordering codes

R_{25} W	No. of R/T characteristic	$B_{25/100}$ K	Ordering code
2 k	1008	$3560 \pm 1\%$	B57964S0202+000
2.8 k	8016	$3988 \pm 1\%$	B57964S0282+000
5 k	8016	$3988 \pm 1\%$	B57964S0502+000
10 k	8016	$3988 \pm 1\%$	B57964S0103+000

+ = Resistance tolerance

F = $\pm 1\%$

H = $\pm 3\%$

J = $\pm 5\%$

Note

This series has a specially designed insulation (coating, wire coating) for improved resistance against humidity. The sensors must be protected to avoid any damage of the insulation material during handling and in the application.

Reliability data

Test	Standard	Test conditions	DR_{25}/R_{25} (typical)	Remarks
Storage in dry heat	IEC 60068-2-2	Storage at upper category temperature T: 155 °C t: 1000 h	< 2%	No visible damage
Storage in damp heat, steady state	IEC 60068-2-78	Temperature of air: 40 °C Relative humidity of air: 93% Duration: 56 days	< 1%	No visible damage
Rapid temperature cycling	IEC 60068-2-14	Lower test temperature: 55 °C Upper test temperature: 155 °C Number of cycles: 100	< 2%	No visible damage
Long-term stability (empirical value)		Temperature: 70 °C t: 10000 h	< 3%	No visible damage



R/T characteristics

R/T No.	1008		8016	
T (°C)	B _{25/100} = 3560 K		B _{25/100} = 3988 K	
	R _T /R ₂₅	a (%/K)	R _T /R ₂₅	a (%/K)
55.0	53.104	6.1	96.3	7.4
50.0	39.318	6.0	67.01	7.2
45.0	29.325	5.8	47.17	6.9
40.0	22.03	5.7	33.65	6.7
35.0	16.666	5.5	24.26	6.4
30.0	12.696	5.4	17.7	6.2
25.0	9.7251	5.2	13.04	6.0
20.0	7.5171	5.1	9.707	5.8
15.0	5.8353	4.9	7.293	5.6
10.0	4.5686	4.8	5.533	5.5
5.0	3.605	4.7	4.232	5.3
0.0	2.8665	4.5	3.265	5.1
5.0	2.2907	4.4	2.539	5.0
10.0	1.8438	4.3	1.99	4.8
15.0	1.492	4.1	1.571	4.7
20.0	1.2154	4.0	1.249	4.5
25.0	1.0000	3.9	1.0000	4.4
30.0	0.82976	3.8	0.8057	4.3
35.0	0.68635	3.7	0.6531	4.1
40.0	0.57103	3.6	0.5327	4.0
45.0	0.48015	3.5	0.4369	3.9
50.0	0.40545	3.4	0.3603	3.8
55.0	0.3417	3.3	0.2986	3.7
60.0	0.28952	3.2	0.2488	3.6
65.0	0.24714	3.1	0.2083	3.5
70.0	0.21183	3.1	0.1752	3.4
75.0	0.18194	3.0	0.1481	3.3
80.0	0.1568	2.9	0.1258	3.2
85.0	0.13592	2.8	0.1072	3.2
90.0	0.11822	2.8	0.09177	3.1
95.0	0.1034	2.7	0.07885	3.0
100.0	0.090741	2.6	0.068	2.9
105.0	0.079642	2.6	0.05886	2.9
110.0	0.070102	2.5	0.05112	2.8
115.0	0.061889	2.4	0.04454	2.7
120.0	0.054785	2.4	0.03893	2.6
125.0	0.048706	2.3	0.03417	2.6
130.0	0.043415	2.3	0.03009	2.5
135.0	0.038722	2.2	0.02654	2.5
140.0	0.034615	2.2	0.02348	2.4
145.0	0.031048	2.1	0.02083	2.4
150.0	0.02791	2.1	0.01853	2.3
155.0	0.025193	2.0	0.01653	2.3

R/T No.	1008		8016	
T (°C)	B _{25/100} = 3560 K		B _{25/100} = 3988 K	
	R _T /R ₂₅	a (%/K)	R _T /R ₂₅	a (%/K)
160.0	0.02279	2.0		
165.0	0.020667	2.0		
170.0	0.01878	1.9		
175.0	0.01709	1.9		
180.0	0.015582	1.8		
185.0	0.014227	1.8		
190.0	0.013012	1.8		
195.0	0.011934	1.7		
200.0	0.010964	1.7		
205.0	0.0101	1.7		
210.0	0.0093191	1.6		
215.0	0.0085949	1.6		
220.0	0.0079384	1.6		
225.0	0.0073411	1.5		
230.0	0.006798	1.5		
235.0	0.0063087	1.5		
240.0	0.0058623	1.5		
245.0	0.0054487	1.4		
250.0	0.0050705	1.4		

Types of packing

Ammo packing

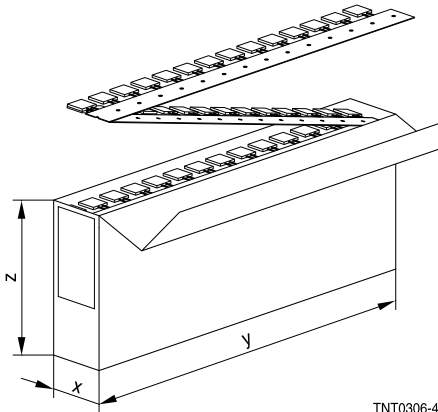

TNT0306-4

Ammo type	x	y	z
I	80	240	210

Packing unit: 1000 - 2000 pcs./reel

Reel packing

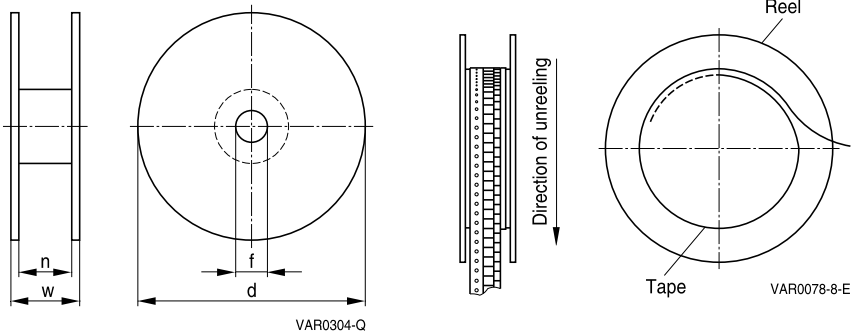

Packing unit: 1000 - 2000 pcs./reel

Reel dimensions (in mm)

Reel type	d	f	n	w
I	360 max.	31 ±1	approx. 45	54 max.
II	500 max.	23 ±1	approx. 59	72 max.

Cassette packing

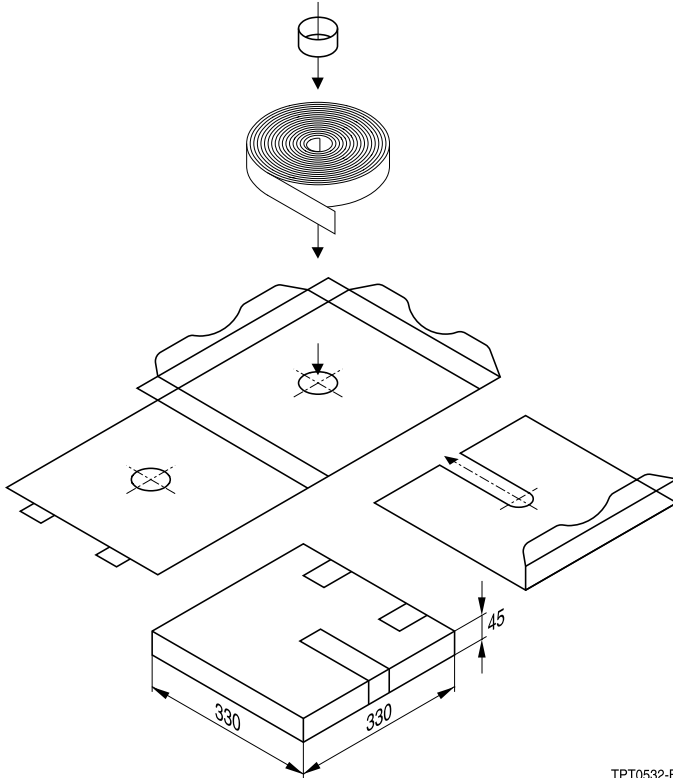

TPT0532-B

Packing unit: 1000 - 2000 pcs./cassette

Bulk packing

The components are packed in cardboard boxes, the size of which depends on the order quantity.

2 Packing codes

The last two digits of the complete ordering code state the packing mode:

Last two digits			
00, 01, 02, 03, 04, 05, 06, 07, 08		Bulk	
40		Bulk	
45		Bulk	
50	Radial leads, kinked	Cardboard tape	Cassette packing
51	Radial leads, kinked	Cardboard tape	360 or 500-mm reel packing
52	Radial leads, straight	Cardboard tape	Cassette packing
53	Radial leads, straight	Cardboard tape	360 or 500-mm reel packing
54	Radial leads, kinked	Cardboard tape	AMMO packing
55	Radial leads, straight	Cardboard tape	AMMO packing
60	SMD	Cardboard tape	180-mm reel packing
62	SMD	Blister tape	180-mm reel packing
70	SMD	Cardboard tape	330-mm reel packing
72	SMD	Blister tape	330-mm reel packing

(If no packing code is indicated, this corresponds to 40)

Example 1:	B57164K0102J000	Bulk
	B57164K0102J052	Cardboard tape, cassette packing
Example 2:	B57881S0103F002	Bulk
	B57881S0103F251	Cardboard tape, reel packing

Mounting instructions

1 Soldering

1.1 Leaded NTC thermistors

Leaded thermistors comply with the solderability requirements specified by CECC.

When soldering, care must be taken that the NTC thermistors are not damaged by excessive heat. The following maximum temperatures, maximum time spans and minimum distances have to be observed:

	Dip soldering	Iron soldering
Bath temperature	max. 260 °C	max. 360 °C
Soldering time	max. 4 s	max. 2 s
Distance from thermistor	min. 6 mm	min. 6 mm

Under more severe soldering conditions the resistance may change.

1.2 Leadless NTC thermistors

In case of NTC thermistors without leads, soldering is restricted to devices which are provided with a solderable metallization. The temperature shock caused by the application of hot solder may produce fine cracks in the ceramic, resulting in changes in resistance.

To prevent leaching of the metallization, solder with silver additives or with a low tin content should be used. In addition, soldering methods should be employed which permit short soldering times.

2 Clamp contacting

Pressure contacting by means of clamps is particularly suitable for applications involving frequent switching and high turn-on powers.

3 Robustness of terminations (leaded types)

The leads meet the requirements of IEC 60068-2-21. They may not be bent closer than 4 mm from the solder joint on the thermistor body or from the point at which they leave the feed-throughs. During bending, any mechanical stress at the outlet of the leads must be removed. The bending radius should be at least 0.75 mm.

Tensile strength: Test Ua1:

Leads	Æ Ø.25 mm =	1.0 N
	0.25 < Æ Ø.35 mm =	2.5 N
	0.35 < Æ Ø.50 mm =	5.0 N
	0.50 < Æ Ø.80 mm =	10.0 N
	0.80 < Æ £1.25 mm =	20.0 N

Bending strength: Test Ub:

Two 90°-bends in opposite directions at a weight of 0.25 kg.

Torsional strength: Test Uc: severity 2

The lead is bent by 90° at a distance of 6 to 6.5 mm from the thermistor body.

The bending radius of the leads should be approx. 0.75 mm. Two torsions of 180° each (severity 2).

When subjecting leads to mechanical stress, the following should be observed:

Tensile stress on leads

During mounting and operation tensile forces on the leads are to be avoided.

Bending of leads

Bending of the leads directly on the thermistor body is not permissible.

A lead may be bent at a minimum distance of twice the wire's diameter +2 mm from the solder joint on the thermistor body. During bending the wire must be mechanically relieved at its outlet. The bending radius should be at least 0.75 mm.

Twisting of leads

The twisting (torsion) by 180° of a lead bent by 90° is permissible at 6 mm from the bottom of the thermistor body.

4 Sealing and potting

When thermistors are sealed, potted or overmolded, there must be no mechanical stress caused by thermal expansion during the production process (curing / overmolding process) and during later operation. The upper category temperature of the thermistor must not be exceeded. Ensure that the materials used (sealing / potting compound and plastic material) are chemically neutral.

5 Cleaning

If cleaning is necessary, mild cleaning agents such as ethyl alcohol and cleaning gasoline are recommended. Cleaning agents based on water are not allowed. Ultrasonic cleaning methods are permissible.

6 Storage

In order to maintain their solderability, thermistors must be stored in a non-corrosive atmosphere. Humidity, temperature and container materials are critical factors.

Do not store SMDs where they are exposed to heat or direct sunlight. Otherwise, the packing material may be deformed or SMDs may stick together, causing problems during mounting. After opening the factory seals, such as polyvinyl-sealed packages, use the SMDs as soon as possible.

The components should be left in the original packing. Touching the metallization of unsoldered thermistors may change their soldering properties.

Storage temperature: 25 °C up to 45 °C

Relative humidity (without condensation): £75% annual mean

<95%, maximum 30 days per annum

Solder the thermistors listed in this data book after shipment from EPCOS within the time specified:

SMDs: 12 months

Leaded components: 24 months

Cautions and warnings

General

See "Important notes" at the end of this document.

Storage

- Store thermistors only in original packaging. Do not open the package prior to storage.
- Storage conditions in original packaging: storage temperature 25 °C ... +45 °C, relative humidity £75% annual mean, <95% maximum 30 days per annum, dew precipitation is inadmissible.
- Do not store thermistors where they are exposed to heat or direct sunlight. Otherwise, the packing material may be deformed or components may stick together, causing problems during mounting.
- Avoid contamination of thermistor surface during storage, handling and processing.
- Avoid storage of thermistors in harmful environments like corrosive gases (SO_x, Cl etc).
- Use the components as soon as possible after opening the factory seals, i.e. the polyvinyl-sealed packages.
- Solder thermistors within the time specified after shipment from EPCOS.
For leaded components this is 24 months, for SMDs 12 months.

Handling

- NTC thermistors must not be dropped. Chip-offs or any other damage must not be caused during handling of NTCs.
- Do not touch components with bare hands. Gloves are recommended.
- Avoid contamination of thermistor surface during handling.

Bending / twisting leads

- A lead (wire) may be bent at a minimum distance of twice the wire's diameter plus 4 mm from the component head or housing. When bending ensure the wire is mechanically relieved at the component head or housing. The bending radius should be at least 0.75 mm.
- Twisting (torsion) by 180° of a lead bent by 90° is permissible at 6 mm from the bottom of the thermistor body.

Soldering

- Use resin-type flux or non-activated flux.
- Insufficient preheating may cause ceramic cracks.
- Rapid cooling by dipping in solvent is not recommended.
- Complete removal of flux is recommended.

Mounting

- Ensure that no thermo-mechanical stress occurs due to production processes (curing or overmolding processes) when thermistors are sealed, potted or overmolded or during their subsequent operation. The maximum temperature of the thermistor must not be exceeded. Ensure that the materials used (sealing/potting compound and plastic material) are chemically neutral.
- Electrodes/contacts must not be scratched or damaged before/during/after the mounting process.
- Contacts and housing used for assembly with the thermistor must be clean before mounting.
- Ensure that adjacent materials are designed for operation at temperatures comparable to the surface temperature of the thermistor. Be sure that surrounding parts and materials can withstand the temperature.
- Avoid contamination of the thermistor surface during processing.
- The connections of sensors (e.g. cable end, wire end, plug terminal) may only be exposed to an environment with normal atmospheric conditions.
- Tensile forces on cables or leads must be avoided during mounting and operation.
- Bending or twisting of cables or leads directly on the thermistor body is not permissible.
- Avoid using chemical substances as mounting aids. It must be ensured that no water or other liquids enter the NTC thermistors (e.g. through plug terminals). In particular, water based substances (e.g. soap suds) must not be used as mounting aids for sensors.

Operation

- Use thermistors only within the specified operating temperature range.
- Use thermistors only within the specified power range.
- Environmental conditions must not harm the thermistors. Only use the thermistors under normal atmospheric conditions or within the specified conditions.
- Contact of NTC thermistors with any liquids and solvents should be prevented. It must be ensured that no water enters the NTC thermistors (e.g. through plug terminals). For measurement purposes (checking the specified resistance vs. temperature), the component must not be immersed in water but in suitable liquids (e.g. Galden).
- Avoid dewing and condensation unless thermistor is specified for these conditions.
- Bending or twisting of cables and/or wires is not permissible during operation of the sensor in the application.
- Be sure to provide an appropriate fail-safe function to prevent secondary product damage caused by malfunction.

This listing does not claim to be complete, but merely reflects the experience of EPCOS AG.

Symbols and terms

Symbol	English	German
A	Area	Fläche
AWG	American Wire Gauge	Amerikanische Norm für Drahtquerschnitte
B	B value	B-Wert
$B_{25/100}$	B value determined by resistance measurement at 25 °C and 100 °C	B-Wert, ermittelt durch Widerstandsmessungen bei 25 °C und 100 °C
C_{th}	Heat capacitance	Wärmekapazität
I	Current	Strom
N	Number (integer)	Anzahl (ganzzahliger Wert)
P_{25}	Maximum power at 25 °C	Maximale Leistung bei 25 °C
P_{diss}	Power dissipation	Verlustleistung
P_{el}	Electrical power	Elektrische Leistung
P_{max}	Maximum power within stated temperature range	Maximale Leistung im angegebenen Temperaturbereich
DR_B/R_B	Resistance tolerance caused by spread of B value	Widerstandstoleranz, die durch die Streuung des B-Wertes verursacht wird
R_{ins}	Insulation resistance	Isolationswiderstand
R_p	Parallel resistance	Parallelwiderstand
R_R	Rated resistance	Nennwiderstand
DR_R/R_R	Resistance tolerance	Widerstandstoleranz
R_S	Series resistance	Serienwiderstand
R_T	Resistance at temperature T (e.g. R_{25} = resistance at 25 °C)	Widerstand bei Temperatur T (z.B. R_{25} = Widerstand bei 25 °C)
T	Temperature	Temperatur
DT	Temperature tolerance	Temperaturtoleranz
t	Time	Zeit
T_A	Ambient temperature	Umgebungstemperatur
T_{max}	Upper category temperature	Obere Grenztemperatur (Kategorietemperatur)
T_{min}	Lower category temperature	Untere Grenztemperatur (Kategorietemperatur)
T_{op}	Operating temperature	Betriebstemperatur
T_R	Rated temperature	Nenntemperatur
T_{surf}	Surface temperature	Oberflächentemperatur
V	Voltage	Spannung
V_{ins}	Insulation test voltage	Isolationsprüfspannung
V_{op}	Operating voltage	Betriebsspannung
V_{test}	Test voltage	Prüfspannung

Symbol	English	German
a	Temperature coefficient	Temperaturkoeffizient
D	Tolerance, change	Toleranz, Änderung
d _{th}	Dissipation factor	Wärmeleitwert
t _c	Thermal cooling time constant	Thermische Abkühlzeitkonstante
t _a	Thermal time constant	Thermische Zeitkonstante

Abbreviations / Notes

Symbol	English	German
<u>SMD</u>	Surface-mounted devices	Oberflächenmontierbares Bauelement
*	To be replaced by a number in ordering codes, type designations etc.	Platzhalter für Zahl im Bestellnummerncode oder für die Typenbezeichnung.
+	To be replaced by a letter. All dimensions are given in mm. The commas used in numerical values denote decimal points.	Platzhalter für einen Buchstaben. Alle Maße sind in mm angegeben. Verwendete Kommas in Zahlenwerten bezeichnen Dezimalpunkte.

The following applies to all products named in this publication:

1. Some parts of this publication contain statements about the suitability of our products for certain areas of application. These statements are based on our knowledge of typical requirements that are often placed on our products in the areas of application concerned. We nevertheless expressly point out that such statements cannot be regarded as binding statements about the suitability of our products for a particular customer application. As a rule, EPCOS is either unfamiliar with individual customer applications or less familiar with them than the customers themselves. For these reasons, it is always ultimately incumbent on the customer to check and decide whether an EPCOS product with the properties described in the product specification is suitable for use in a particular customer application.
2. We also point out that in individual cases, a malfunction of electronic components or failure before the end of their usual service life cannot be completely ruled out in the current state of the art, even if they are operated as specified. In customer applications requiring a very high level of operational safety and especially in customer applications in which the malfunction or failure of an electronic component could endanger human life or health (e.g. in accident prevention or lifesaving systems), it must therefore be ensured by means of suitable design of the customer application or other action taken by the customer (e.g. installation of protective circuitry or redundancy) that no injury or damage is sustained by third parties in the event of malfunction or failure of an electronic component.
3. The warnings, cautions and product-specific notes must be observed.
4. In order to satisfy certain technical requirements, some of the products described in this publication may contain substances subject to restrictions in certain jurisdictions (e.g. because they are classed as hazardous). Useful information on this will be found in our Material Data Sheets on the Internet (www.epcos.com/material). Should you have any more detailed questions, please contact our sales offices.
5. We constantly strive to improve our products. Consequently, the products described in this publication may change from time to time. The same is true of the corresponding product specifications. Please check therefore to what extent product descriptions and specifications contained in this publication are still applicable before or when you place an order. We also reserve the right to discontinue production and delivery of products. Consequently, we cannot guarantee that all products named in this publication will always be available. The aforementioned does not apply in the case of individual agreements deviating from the foregoing for customer-specific products.
6. Unless otherwise agreed in individual contracts, all orders are subject to the current version of the "General Terms of Delivery for Products and Services in the Electrical Industry" published by the German Electrical and Electronics Industry Association (ZVEI).
7. The trade names EPCOS, BAOKE, Alu-X, CeraDiode, CSMP, CSSP, CTVS, DeltaCap, DigiSiMic, DSSP, FormFit, MiniBlue, MiniCell, MKD, MKK, MLSC, MotorCap, PCC, PhaseCap, PhaseCube, PhaseMod, PhiCap, SIFERRIT, SIFI, SIKOREL, SilverCap, SIMDAD, SiMic, SIMID, SineFormer, SIOV, SIP5D, SIP5K, ThermoFuse, WindCap are trademarks registered or pending in Europe and in other countries. Further information will be found on the Internet at www.epcos.com/trademarks.