

Accessories

Modular bus covers

CANopen®

Hollow shaft encoders / types G1, G2



View inside bus cover

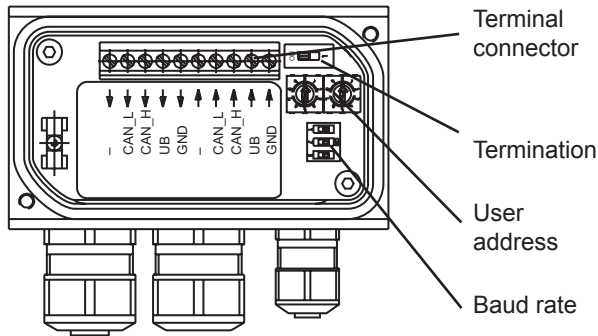

Bus cover

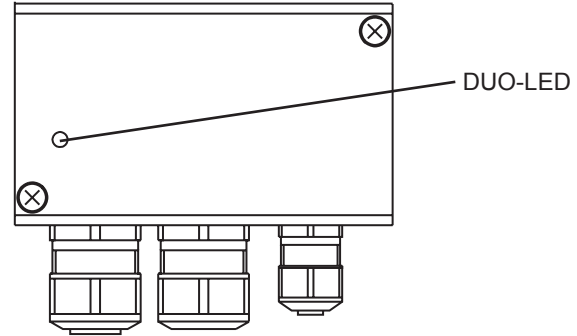

Features - CANopen®

Bus protocol	CANopen®
Device profile	CANopen® - CiA DSP 406, V 3.0 (Device Class 2, CAN 2.0B)
Operating modes	Event-triggered Time-triggered Remotely-requested Sync (cyclic) Sync (acyclic)
Preset	Parameter for setting the encoder to a requested position value assigned to a defined shaft position of the system. The offset of encoder zero point and mechanical zero point is stored in the encoder.
Rotating direction	Parameter for defining the rotating direction in which there have to be ascending or descending position values.
Scaling	Parameter defining the steps per turn as well as the total resolution.
Diagnosis	The encoder supports the following error warnings: - Position and parameter error - Lithium battery voltage control (Multiturn)
Node ID monitoring	Heartbeat or Nodeguarding
Default	50 kbit/s, Node ID 1

Part number

Z 167.5P32 CANopen for G1 and G2

Terminal assignment

CAN_L	CAN bus signal (dominant Low)
CAN_H	CAN bus signal (dominant High)
UB	Voltage supply 10...30 VDC
GND	Ground connection relating to UB

Terminals of the same significance are internally connected and identical in their functions. Max. load on the internal terminal connections UB-UB and GND-GND is 1 A each.

Termination

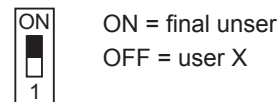

User address (identifier)

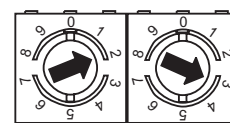

Defined by rotary switch.
Example: User address 23

Baud rate

Baud rate	Dip switch position		
	1	2	3
10 kbit/s	OFF	OFF	OFF
20 kbit/s	OFF	OFF	ON
50 kbit/s	OFF	ON	OFF
125 kbit/s	OFF	ON	ON
250 kbit/s	ON	OFF	OFF
500 kbit/s	ON	OFF	ON
800 kbit/s	ON	ON	OFF
1 MBit/s	ON	ON	ON

If the user address is 00 the baud rate and Node ID are programmable via CAN bus.

Accessories

Modular bus covers

DeviceNet



Hollow shaft encoders / types G1, G2

View inside bus cover

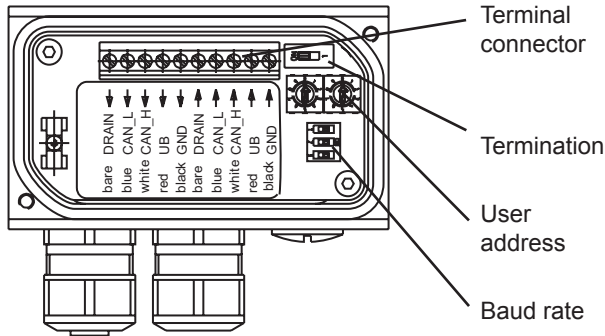

Bus cover

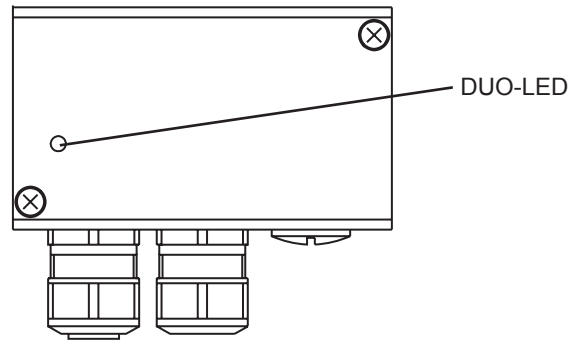

Features - DeviceNet

Bus protocol	DeviceNet
Device profile	Device Profil for Encoders V 1.0
Operating modes	I/O-Polling Cyclic Change of State
Preset	Parameter for setting the encoder to a requested position value assigned to a defined shaft position of the system. The offset of encoder zero point and mechanical zero point is stored in the encoder.
Rotating direction	Parameter for defining the rotating direction in which there have to be ascending or descending position values.
Scaling	Parameter defining the steps per turn as well as the total resolution.
Diagnosis	The encoder supports the following error warnings: - Position and parameter error - Lithium battery voltage control (Multiturn)
Default	125 kbit/s, Mac ID 63

Terminal assignment

CAN_L	CAN bus signal (dominant Low)
CAN_H	CAN bus signal (dominant High)
DRAIN	Shield
UB	Voltage supply 10...30 VDC
GND	Ground connection relating to UB

Terminals of the same significance are internally connected and identical in their functions. Max. load on the internal terminal connections UB-UB and GND-GND is 1 A each.

Termination

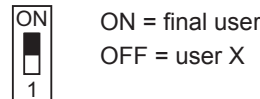

ON = final user
OFF = user X

User address (identifier)

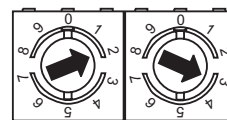

Defined by rotary switch.
Example: User address 23

Part number

Z 167.8P22 DeviceNet for G1 and G2

Baud rate

Baud rate	Dip switch position		
	1	2	3
125 kBit/s	X	OFF	OFF
250 kBit/s	X	OFF	ON
500 kBit/s	X	ON	OFF
125 kBit/s*	X	ON	ON

X = without function

* = This switch position is not defined, therefore internally set to default 125 kBit/s.

Accessories

Modular bus covers

Profibus-DPV0



Hollow shaft encoders / types G1, G2

View inside bus cover

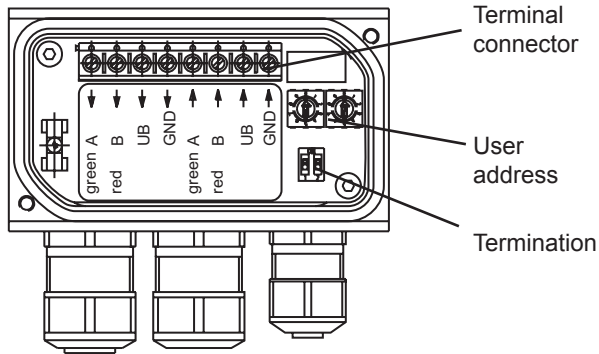

Bus cover

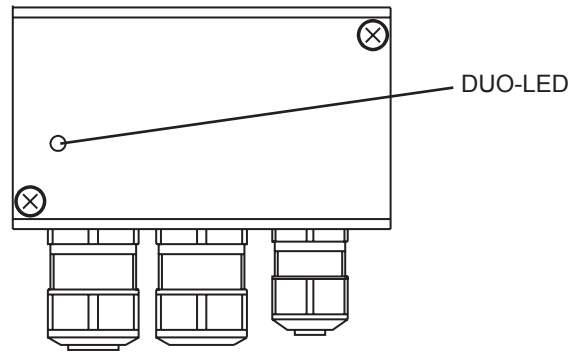

Features - Profibus-DPV0

Bus protocol	Profibus-DPV0
Device profile	Device Class 1 and 2
Cyclic data	Communication by synchronous clock exchange (IsoM) in line with DPV0
Input data	Position value. In addition optionally speed signal parametering (output of current rotation speed).
Output data	Preset
Preset	Parameter for setting the encoder to a requested position value assigned to a defined shaft position of the system. Storage non-volatile.
Rotating direction	Parameter for defining the rotating direction in which there have to be ascending or descending position values.
Scaling	Parameter defining the steps per turn as well as the total resolution.
Diagnosis	The encoder supports the following error warnings: - Position and parameter error - Lithium battery voltage control (Multiturn)
Default	User address 00 Termination OFF

Terminal assignment

A	Negativ data line
B	Positive data line
UB	Voltage supply 10...30 VDC
GND	Ground connection relating to UB

Terminals of the same significance are internally connected and identical in their functions. Max. load on the internal terminal connections UB-UB and GND-GND is 1 A each.

Termination

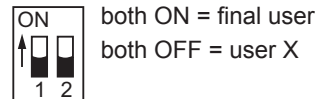

User address (identifier)

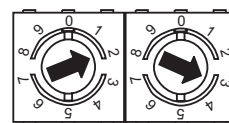

Defined by rotary switch.
Example: User address 23

Part number

Z 167.3P32 Profibus-DPV0 for G1 and G2