

Accessories

Modular bus covers

CANopen®

Hollow shaft encoders / types G0, GB, GE

CANopen

View inside bus cover

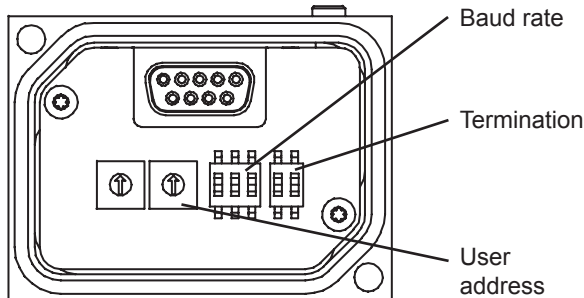

View inside bus cover

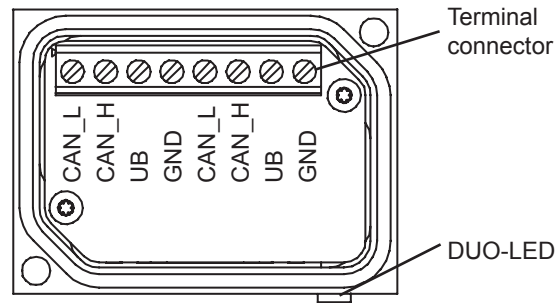

Features - CANopen®

Bus protocol	CANopen®
Device profile	CANopen® - CiA DSP 406, V 3.0 Device Class 2, CAN 2.0B)
Operating modes	Event-triggered Time-triggered Remotely-requested Sync (cyclic) Sync (acyclic)
Preset	Parameter for setting the encoder to a requested position value assigned to a defined shaft position of the system. The offset of encoder zero point and mechanical zero point is stored in the encoder.
Rotating direction	Parameter for defining the rotating direction in which there have to be ascending or descending position values.
Scaling	Parameter defining the steps per turn as well as the total resolution.
Diagnosis	The encoder supports the following error warnings: - Position and parameter error - Lithium battery voltage control (Multiturn)
Node ID monitoring	Heartbeat or Nodeguarding
Default	50 kbit/s, Node ID 1

Part number

Z 183.5P32	CANopen for G0, GB, GE
Z 188.5P32	CANopen for G0, GB, GE in stainless steel

Terminal assignment

CAN_L	CAN bus signal (dominant Low)
CAN_H	CAN bus signal (dominant High)
UB	Voltage supply 10...30 VDC
GND	Ground connection relating to UB

Terminals of the same significance are internally connected and identical in their functions. Max. load on the internal terminal connections UB-UB and GND-GND is 1 A each.

Termination



Switch 1:
ON = final user, OFF = user X
Switch 2:
without function

User address (identifier)

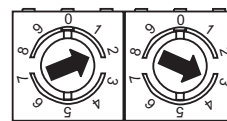

Defined by rotary switch.
Example: User address 23

Baud rate



Baud rate	Dip switch position		
	1	2	3
10 kbit/s	OFF	OFF	OFF
20 kbit/s	OFF	OFF	ON
50 kbit/s	OFF	ON	OFF
125 kbit/s	OFF	ON	ON
250 kbit/s	ON	OFF	OFF
500 kbit/s	ON	OFF	ON
800 kbit/s	ON	ON	OFF
1 MBit/s	ON	ON	ON

If the user address is 00 the baud rate and Node ID are programmable via CAN bus.

Accessories

Modular bus covers

DeviceNet



Hollow shaft encoders / types G0, GB, GE

View inside bus cover

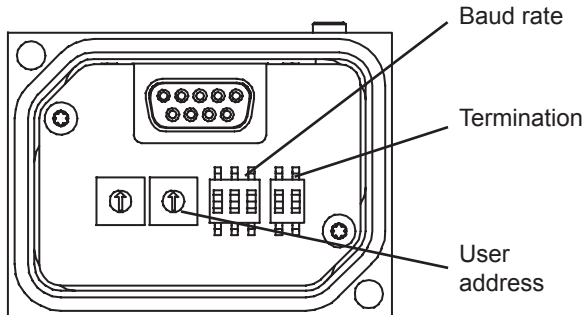

View inside bus cover

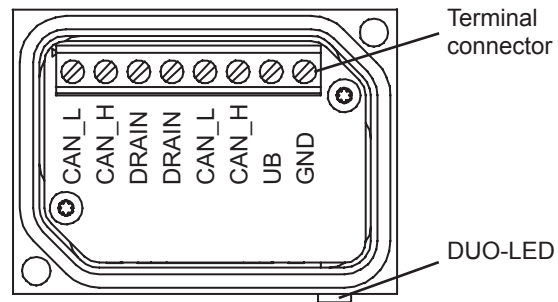

Features - DeviceNet

Bus protocol	DeviceNet
Device profile	Device Profile for Encoders V 1.0
Operating modes	I/O-Polling Cyclic Change of State
Preset	Parameter for setting the encoder to a requested position value assigned to a defined shaft position of the system. The offset of encoder zero point and mechanical zero point is stored in the encoder.
Rotating direction	Parameter for defining the rotating direction in which there have to be ascending or descending position values.
Scaling	Parameter defining the steps per turn as well as the total resolution.
Diagnosis	The encoder supports the following error warnings: - Position and parameter error - Lithium battery voltage control (Multiturn)
Default	125 kbit/s, Mac ID 63

Part number

Z 183.8P22	DeviceNet for G0, GB, GE
Z 188.8P32	DeviceNet for G0, GB, GE in stainless steel

Terminal assignment

CAN_L	CAN bus signal (dominant Low)
CAN_H	CAN bus signal (dominant High)
DRAIN	Shield
UB	Voltage supply 10...30 VDC
GND	Ground connection relating to UB

Terminals of the same significance are internally connected and identical in their functions. Max. load on the internal terminal connections UB-UB and GND-GND is 1 A each.

Termination

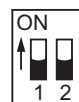

Switch 1:
ON = final user, OFF = user X

Switch 2:
without function

User address (identifier)

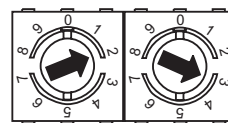

Defined by rotary switch.
Example: User address 23

Baud rate



Baud rate	Dip switch position		
	1	2	3
125 kBit/s	X	OFF	OFF
250 kBit/s	X	OFF	ON
500 kBit/s	X	ON	OFF
125 kBit/s*	X	ON	ON

X = without function

* = This switch position is not defined, therefore internally set to default 125 kBit/s.

Accessories

Modular bus covers

Profibus-DPV0



Hollow shaft encoders / types G0, GB, GE

View inside bus cover

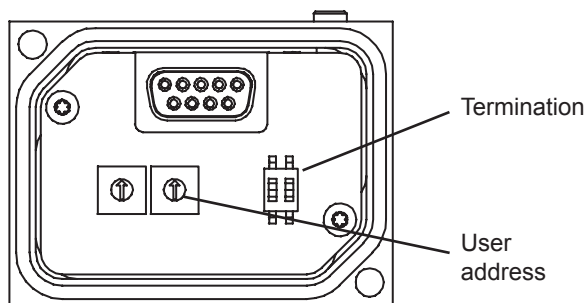

View inside bus cover

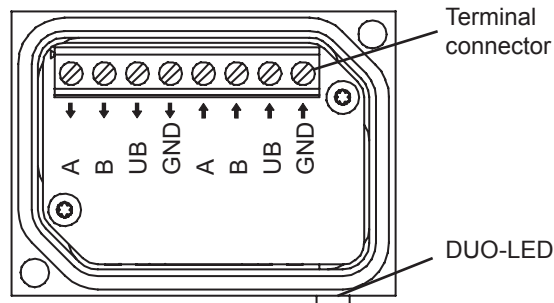

Features - Profibus-DPV0

Bus protocol	Profibus-DPV0
Device profile	Device Class 1 and 2
Cyclic data	Communication by synchronous clock exchange (IsoM) in line with DPV0
Input data	Position value. In addition optionally speed signal parametering (output of current rotation speed)
Output data	Preset
Preset	Parameter for setting the encoder to a requested position value assigned to a defined shaft position of the system. Storage non-volatile.
Rotating direction	Parameter for defining the rotating direction in which there have to be ascending or descending position values.
Scaling	Parameter defining the steps per turn as well as the total resolution.
Diagnosis	The encoder supports the following error warnings: - Position and parameter error - Lithium battery voltage control (Multiturn)
Default	User address 00 Terminator OFF

Terminal assignment

A	Negative data line
B	Positive data line
UB	Voltage supply 10...30 VDC
GND	Ground connection relating to UB

Terminals of the same significance are internally connected and identical in their functions. Max. load on the internal terminal connections UB-UB and GND-GND is 1 A each.

Termination

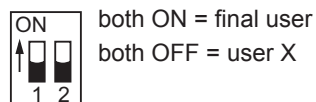

User address (identifier)

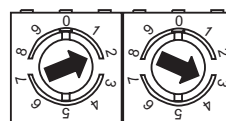

Defined by rotary switch.
Example: User address 23

Part number

Z 183.3P32	Profibus-DPV0 for G0, GB, GE
Z 188.3P32	Profibus-DPV0 for G0, GB, GE stainless steel

Accessories

Modular bus covers

PROFINET



Hollow shaft encoders / types G0, GB, GE

View on bus cover

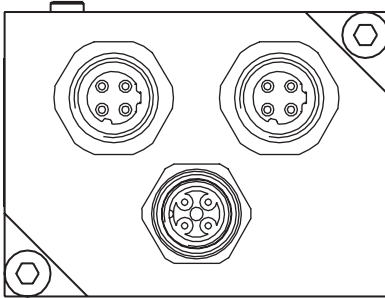

Bus cover

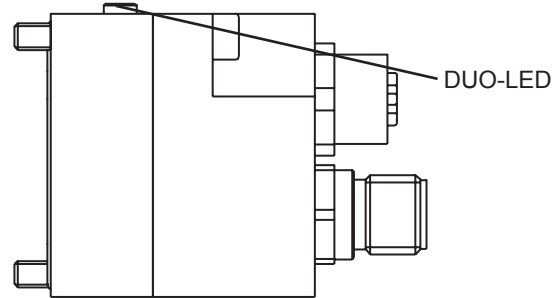

Features - PROFINET

Bus protocol	PROFINET
Device profile	Encoder Profile PNO 3.162
Features	<ul style="list-style-type: none"> - 100 MBaud Fast Ethernet - Automatic address designation - Realtime (RT) Class 1, IRT Class 2, IRT Class 3
Process data	Position value 32 bit input data

Part number

Z 183.3EA2 Bus cover PROFINET

Terminal assignment

Voltage supply

Terminal	Assigned	Significance
Pin 1	UB	Voltage supply
Pin 2	N.C.	Not assigned
Pin 3	GND	Ground
Pin 4	N.C.	Not assigned

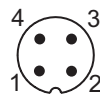

1 x Connector M12 (male), A-coded

PROFINET (data line)

Terminal	Assigned	Significance
Pin 1	TxD+	Transmission data+
Pin 2	RxD+	Receiving data+
Pin 3	TxD-	Transmission data-
Pin 4	RxD-	Receiving data-

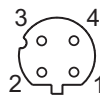

2 x Connector M12 (female), D-coded

Accessories

Z 185.E05	Ethernet cable, connector M12 on both sides with 5 m cable (data line)
Z 185.P05	Connector M12 with 5 m cable, 360° screen (current line)

Accessories

Modular bus covers

EtherNet/IP



Hollow shaft encoders / types G0, GB, GE

View on bus cover

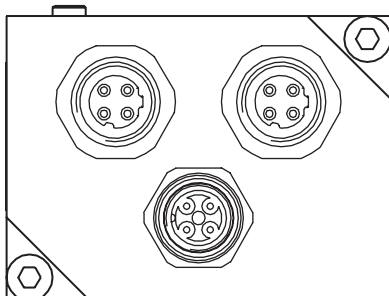

Bus cover

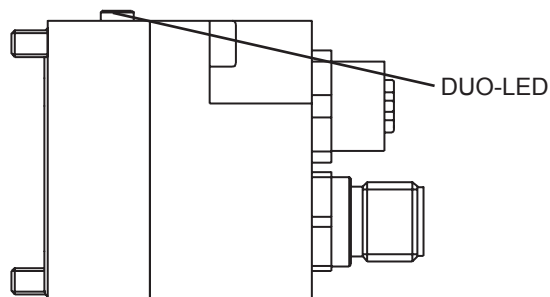

Features - EtherNet/IP

Bus protocol	EtherNet/IP
Device profile	Encoder Device, type 22hex, according to CIP specification
Features	<ul style="list-style-type: none"> - 100 MBaud Fast Ethernet - IP address programmable - Automatic IP address designation (DHCP) - Rotation direction, resolution, total resolution and preset are programmable according to CIP specification
Process data	Position value, Warning Flag, Alarmflag Assembly Instances 1 and 2 according to CIP specification

Part number

Z 183.8EA2 Bus cover EtherNet/IP

Terminal assignment

Voltage supply

Terminal	Assigned	Significance
Pin 1	UB	Voltage supply
Pin 2	N.C.	Not assigned
Pin 3	GND	Ground
Pin 4	N.C.	Not assigned

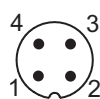

1 x Connector M12 (male), A-coded

EtherNet/IP (data line)

Terminal	Assigned	Significance
Pin 1	TxD+	Transmission data+
Pin 2	RxD+	Receiving data+
Pin 3	TxD-	Transmission data-
Pin 4	RxD-	Receiving data-

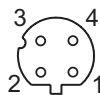

2 x Connector M12 (female), D-coded

Accessories

Z 185.E05	Ethernet cable, connector M12 on both sides with 5 m cable (data line)
Z 185.P05	Connector M12 with 5 m cable, 360° screen (current line)