



# NTC thermistors for inrush current limiting

## Leaded and coated disks

Series/Type: B57464S0\*\*\*M000

Date: August 2012

Applications

- Switch-mode power supplies
- Soft-start motors, e.g. in vacuum cleaners

Features

- Useable in series connections up to 265 V<sub>RMS</sub>
- Coated thermistor disk
- Kinked leads of tinned copper wire
- High energy absorption capability
- Manufacturer's logo, NTC and resistance value stamped on

Options

Resistance tolerance <20%, alternative lead configurations and resistance ratings available on request

Delivery mode

Bulk

General technical data

Climatic category	(IEC 60068-1)		55/170/21	
Max. power	(at 25 °C)	P <sub>max</sub>	6.7	W
Resistance tolerance		DR <sub>R</sub> /R <sub>R</sub>	±20	%
Rated temperature		T <sub>R</sub>	25	°C
Dissipation factor	(in air)	d <sub>th</sub>	approx. 30	mW/K
Thermal cooling time constant	(in air)	t <sub>c</sub>	approx. 130	s
Heat capacity		C <sub>th</sub>	approx. 3900	mJ/K

Dimensional drawing

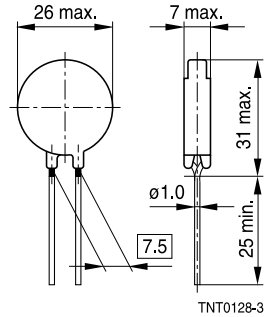

Dimensions in mm  
Approx. weight 9 g

Electrical specification and ordering codes

R <sub>25</sub>	I <sub>max</sub> (0...65 °C)	C <sub>test</sub> <sup>(1)</sup> 230 V AC nF	C <sub>test</sub> <sup>(1)</sup> 110 V AC nF	R <sub>min</sub> (@ I <sub>max</sub> , 25 °C)	Ordering code
W	A			W	
1	20	2500	10000	0.018	B57464S0109M000
2	13.5	2500	10000	0.037	B57464S0209M000
5	9.5	2500	10000	0.071	B57464S0509M000
10	8.0	2500	10000	0.101	B57464S0100M000

1) For details on the capacitance C<sub>test</sub> please refer to "Application notes", chapter 1.6.

**Reliability data**

Test	Standard	Test conditions	DR <sub>25</sub> /R <sub>25</sub> (typical)	Remarks
Storage in dry heat	IEC 60068-2-2	Storage at upper category temperature T: 170 °C t: 1000 h	< 10%	No visible damage
Storage in damp heat, steady state	IEC 60068-2-78	Temperature of air: 40 °C Relative humidity of air: 93% Duration: 21 days	< 5%	No visible damage
Thermal shock	IEC 60068-2-14	Lower test temperature: 55 °C t: 30 min Upper test temperature: 170 °C t: 30 min Time to change from lower to upper temperature: < 30 s Number of cycles: 10	< 10%	No visible damage
Endurance	IEC 60539-1	Ambient temperature: 25 ±5 °C I = I <sub>max</sub> t: 1000 h	< 10%	No visible damage
Cyclic endurance	IEC 60539-1	Ambient temperature: 25 ±5 °C I = I <sub>max</sub> On-time = 1 min Cooling time = 5 min Number of cycles: 1000	< 10%	No visible damage
Maximum permissible capacitance test	IEC 60539-1	Ambient temperature: 25 ±5 °C Capacitance = C <sub>test</sub> Number of cycles: 1000	< 5%	No visible damage

**Note**

- The self-heating of a thermistor during operation depends on the load applied and the applicable dissipation factor.
- When loaded with maximum allowable current/power and the specified dissipation factor is taken as a basis, the NTC thermistor may reach a mean temperature of up to 250 °C.
- The heat developed during operation will also be dissipated through the lead wires. So the contact areas, too, may become quite hot at maximum load.
- When mounting NTC thermistors you have to ensure that there is an adequate distance between the thermistor and all parts which are sensitive to heat or combustible.

Resistance versus temperature

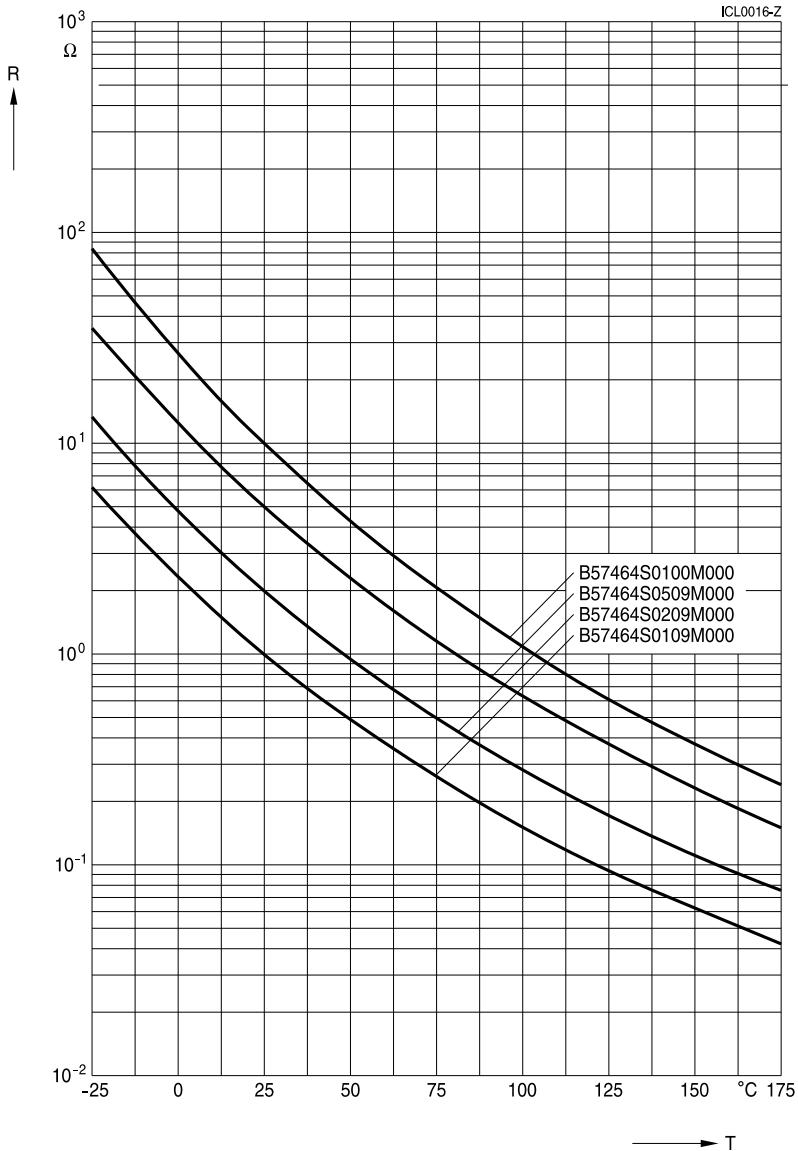

S464 series

Resistance versus current

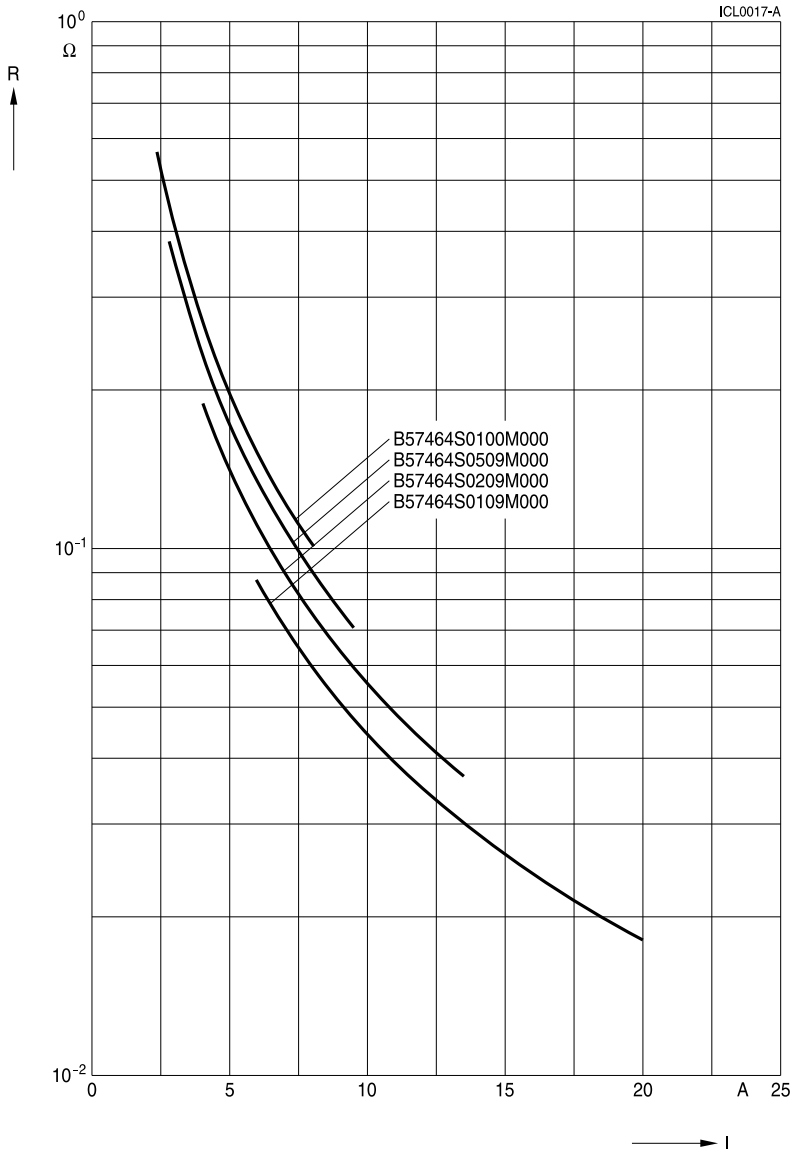

S464 series

Taping and packing

- 1 Taping of radial leaded ICL NTC thermistors according to the specified lead spacing

Dimensions and tolerances

Lead spacing  $F = 5.0 \text{ mm}$  (taping to IEC 60286-2)

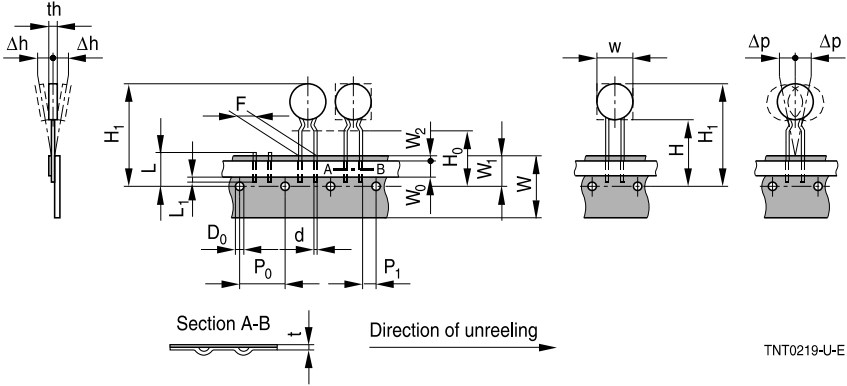

Lead spacing  $F = 7.5 \text{ mm}$  (taping based on IEC 60286-2)

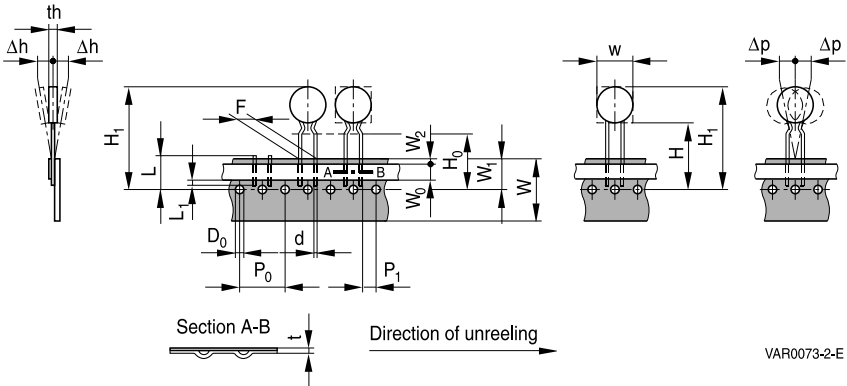

**Dimensions (mm)**

	Lead spacing 5 mm	Tolerance of lead spacing 5 mm	Lead spacing 7.5 mm	Tolerance of lead spacing 7.5 mm	Remarks
w	£12.0	max.	<sup>3</sup> 12.0	max.	please refer to dimensional drawings
th	6.0	max.	7	max.	please refer to dimensional drawings
d	0.5/0.6	±0.05	0.8/1.0	±0.05	please refer to dimensional drawings
P <sub>0</sub>	12.7	±0.3	12.7	±0.3	±1 mm / 20 sprocket holes
P <sub>1</sub>	3.85	±0.7	8.95	±0.8	
F	5.0	+0.6/ 0.1	7.5	±0.8	
Dh	0	±2.0	0	Depends on th	measured at top of component body
Dp	0	±1.3	0	±2.0	
W	18.0	±0.5	18.0	±0.5	
W <sub>0</sub>	5.5	min.	11.0	min.	peel-off force <sup>3</sup> 5 N
W <sub>1</sub>	9.0	+0.75/ 0.5	9.0	+0.75/ 0.5	
W <sub>2</sub>	3.0	max.	3.0	max.	
H	18.0	+2.0/ 0	18.0	+2.0/ 0	
H <sub>0</sub>	16.0	±0.5	16.0	±0.5	
H <sub>1</sub>	32.2	max.	45.0	max.	
D <sub>0</sub>	4.0	±0.2	4.0	±0.2	
t	0.9	max.	0.9	max.	without wires
L	11.0	max.	11.0	max.	
L <sub>1</sub>	4.0	max.	4.0	max.	

Types of packing

Reel packing

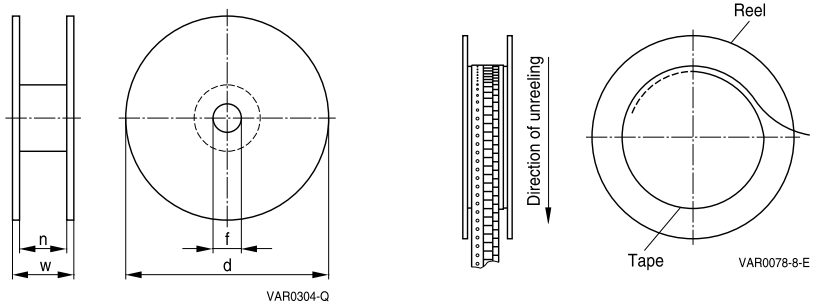

Reel dimensions (in mm)

Reel type	d	f	n	w
I	360 max.	31 ±1	approx. 45	54 max.
II	500 max.	23 ±1	approx. 59	72 max.

Bulk packing

The components are packed in cardboard boxes, the size of which depends on the order quantity.

**Mounting instructions**
**1 Soldering**
**1.1 Leaded NTC thermistors**

Leaded thermistors comply with the solderability requirements specified by CECC.

When soldering, care must be taken that the NTC thermistors are not damaged by excessive heat. The following maximum temperatures, maximum time spans and minimum distances have to be observed:

	Dip soldering	Iron soldering
Bath temperature	max. 260 °C	max. 360 °C
Soldering time	max. 4 s	max. 2 s
Distance from thermistor	min. 6 mm	min. 6 mm

Under more severe soldering conditions the resistance may change.

Solderability (test to IEC 60068-2-20)

Preconditioning: Immersion into flux F-SW 32.

Evaluation criterion: Wetting of soldering areas <sup>3</sup> 95%.

Solder	Bath temperature (°C)	Dwell time (s)
SnAg (3.0 ... 4.0), Cu (0.5 ... 0.9)	245 ±3	3

**1.1.1 Resistance to soldering heat (test to IEC 60068-2-20)**

Preconditioning: Immersion into flux F-SW 32.

Solder	Bath temperature (°C)	Dwell time (s)
SnAg (3.0 ... 4.0), Cu (0.5 ... 0.9)	260 5	10

Wave soldering

Temperature characteristic at component terminal with dual wave soldering

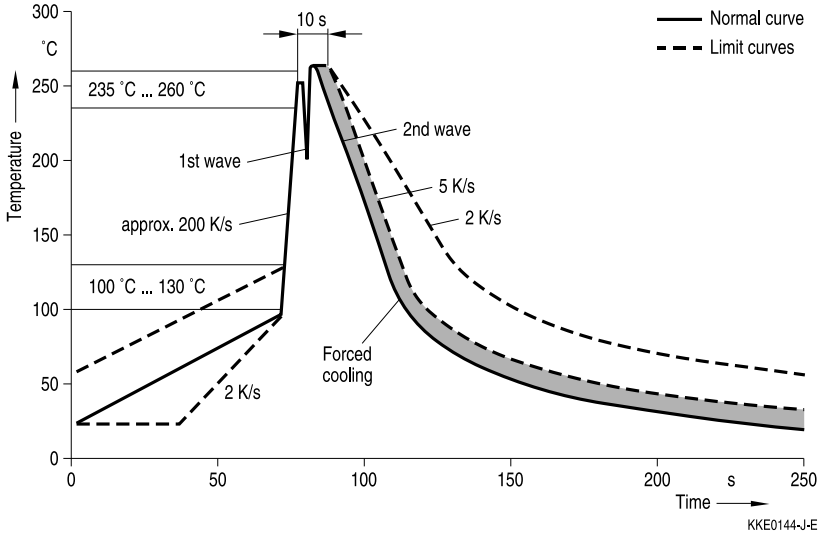

2 Robustness of terminations

The leads meet the requirements of IEC 60068-2-21. They may not be bent closer than 4 mm from the solder joint on the thermistor body or from the point at which they leave the feed-throughs. During bending, any mechanical stress at the outlet of the leads must be removed. The bending radius should be at least 0.75 mm.

Tensile strength: Test Ua1:

- Leads 0.50 <math>\leq \varnothing \leq 0.80 \text{ mm}</math> = 10.0 N
- 0.80 <math>\leq \varnothing \leq 1.25 \text{ mm}</math> = 20.0 N

Bending strength: Test Ub:

Two 90°-bends in opposite directions at a weight of 0.25 kg.

Torsional strength: Test Uc: severity 2

The lead is bent by 90° at a distance of 6 to 6.5 mm from the thermistor body.

The bending radius of the leads should be approx. 0.75 mm. Two torsions of 180° each (severity 2).

When subjecting leads to mechanical stress, the following should be observed:

#### Tensile stress on leads

During mounting and operation tensile forces on the leads are to be avoided.

#### Bending of leads

Bending of the leads directly on the thermistor body is not permissible.

A lead may be bent at a minimum distance of twice the wire's diameter +2 mm from the solder joint on the thermistor body. During bending the wire must be mechanically relieved at its outlet. The bending radius should be at least 0.75 mm.

#### Twisting of leads

The twisting (torsion) by 180° of a lead bent by 90° is permissible at 6 mm from the bottom of the thermistor body.

### 3 Sealing and potting

When thermistors are sealed, potted or overmolded, there must be no mechanical stress caused by thermal expansion during the production process (curing / overmolding process) and during later operation. The upper category temperature of the thermistor must not be exceeded. Ensure that the materials used (sealing / potting compound and plastic material) are chemically neutral.

### 4 Cleaning

If cleaning is necessary, mild cleaning agents such as ethyl alcohol and cleaning gasoline are recommended. Cleaning agents based on water are not allowed. Ultrasonic cleaning methods are permissible.

### 5 Storage

In order to maintain their solderability, thermistors must be stored in a non-corrosive atmosphere. Humidity, temperature and container materials are critical factors.

The components should be left in the original packing. Touching the metallization of unsoldered thermistors may change their soldering properties.

Storage temperature: 25 °C up to 45 °C

Max. relative humidity (without condensation): <95%, maximum 30 days per annum

Solder the thermistors listed in this data book after shipment from EPCOS within the time specified:

Leaded components: 24 months

## Cautions and warnings

### General

See "Important notes" at the end of this document.

### Storage

- Store thermistors only in original packaging. Do not open the package before storage.
- Storage conditions in original packaging: storage temperature 25 °C ... +45 °C, relative humidity £75% annual mean, maximum 95%, dew precipitation is inadmissible.
- Avoid contamination of thermistors surface during storage, handling and processing.
- Avoid storage of thermistor in harmful environments like corrosive gases (SO<sub>x</sub>, Cl etc).
- Solder thermistors after shipment from EPCOS within the time specified:  
Leaded components: 24 months

### Handling

- NTC thermistors must not be dropped. Chip-offs must not be caused during handling of NTCs.
- Components must not be touched with bare hands. Gloves are recommended.
- Avoid contamination of thermistor surface during handling.
- In case of exposure of the NTC thermistors to water, electrolytes or other aggressive media, these media can penetrate the coating and reach the surface of the ceramic. Low-ohmic or high-ohmic behavior may occur due to the formation of an electrolyte with metals (silver/lead/tin from metallization or solder). Low-ohmic behavior is caused by electrochemical migration, high-ohmic behavior by dissolving of the electrode. In either case, the functionality of the NTC thermistors can not be assured.

### Bending / twisting leads

- A lead (wire) may be bent at a minimum distance of twice the wire's diameter plus 4 mm from the component head or housing. When bending ensure the wire is mechanically relieved at the component head or housing. The bending radius should be at least 0.75 mm.
- Twisting (torsion) by 180° of a lead bent by 90° is permissible at 6 mm from the bottom of the thermistor body.

### Soldering

- Use resin-type flux or non-activated flux.
- Insufficient preheating may cause ceramic cracks.
- Rapid cooling by dipping in solvent is not recommended.
- Complete removal of flux is recommended.

## Mounting

- When NTC thermistors are encapsulated with sealing material or overmolded with plastic material, the precautions given in chapter "Mounting instructions", "Sealing and potting" must be observed.
- Electrode must not be scratched before/during/after the mounting process.
- Contacts and housings used for assembly with thermistor have to be clean before mounting.
- During operation, the inrush current limiters surface temperature can be very high. Ensure that adjacent components are placed at a sufficient distance from the thermistor to allow for proper cooling of the thermistors.
- Ensure that adjacent materials are designed for operation at temperatures comparable to the surface temperature of the thermistor. Be sure that surrounding parts and materials can withstand this temperature.
- Make sure that inrush current limiters are adequately ventilated to avoid overheating.
- Avoid contamination of thermistor surface during processing.

## Operation

- Use thermistors only within the specified operating temperature range.
- Use inrush current limiters only within the specified voltage and current ranges.
- Environmental conditions must not harm the thermistors. Use thermistors only in normal atmospheric conditions.
- Contact of NTC thermistors with any liquids and solvents should be prevented. It must be ensured that no water enters the NTC thermistor (e.g. through plug terminals). For measurement purposes (checking the specified resistance vs. temperature), the component must not be immersed in water but in suitable liquids (e.g. Galden).
- In case of exposure of the NTC thermistors to water, electrolytes or other aggressive media, these media can penetrate the coating and reach the surface of the ceramic. Low-ohmic or high-ohmic behavior may occur due to the formation of an electrolyte with metals (silver/lead/tin from metallization or solder). Low-ohmic behavior is caused by electrochemical migration, high-ohmic behavior by dissolving of the electrode. In either case, the functionality of the NTC thermistors cannot be assured.
- Be sure to provide an appropriate fail-safe function to prevent secondary product damage caused by malfunction (e.g. use a metal oxide varistor for limitation of overvoltage condition).

**Symbols and terms**

Symbol	English	German
$C_{\text{test}}$	Test capacitance	Prüfkapazität (elektrisch)
$C_{\text{th}}$	Heat capacitance	Wärmekapazität
$I$	Current	Strom
$I_{\text{max}}$	Maximum current within stated temperature range	Maximalstrom im angegebenen Temperaturbereich
$I_{\text{NTC}}$	NTC current	Heißleiter-Strom
$I_{\text{R}}$	Rated current	Nennstrom
$P_{25}$	Maximum power at 25 °C	Maximale Leistung bei 25 °C
$P_{\text{diss}}$	Power dissipation	Verlustleistung
$P_{\text{el}}$	Electrical power	Elektrische Leistung
$P_{\text{max}}$	Maximum power within stated temperature range	Maximale Leistung im angegebenen Temperaturbereich
$R_{\text{R}}$	Rated resistance	Nennwiderstand
$DR_{\text{R}}/R_{\text{R}}$	Resistance tolerance	Widerstandstoleranz
$R_{\text{T}}$	Resistance at temperature T (e.g. $R_{25}$ = resistance at 25 °C)	Widerstand bei Temperatur T (z.B. $R_{25}$ = Widerstand bei 25 °C)
$T$	Temperature	Temperatur
$t$	Time	Zeit
$T_{\text{A}}$	Ambient temperature	Umgebungstemperatur
$t_{\text{a}}$	Thermal threshold time	Thermische Ansprechzeit
$T_{\text{max}}$	Upper category temperature	Obere Grenztemperatur (Kategorietemperatur)
$T_{\text{min}}$	Lower category temperature	Untere Grenztemperatur (Kategorietemperatur)
$T_{\text{R}}$	Rated temperature	Nenntemperatur
$V$	Voltage	Spannung
$V_{\text{load}}$	Load voltage	Ladespannung
$V_{\text{NTC}}$	Voltage drop across an NTC thermistor	Spannungsabfall am Heißleiter
$a$	Temperature coefficient	Temperaturkoeffizient
$D$	Tolerance, change	Toleranz, Änderung
$d_{\text{th}}$	Dissipation factor	Wärmeleitwert
$t_{\text{c}}$	Thermal cooling time constant	Thermische Abkühlzeitkonstante

Abbreviations / Notes

Symbol	English	German
*	To be replaced by a number in ordering codes, type designations etc.	Platzhalter für Zahl im Bestellnummerncode oder für die Typenbezeichnung.
+	To be replaced by a letter. All dimensions are given in mm. The commas used in numerical values denote decimal points.	Platzhalter für einen Buchstaben. Alle Maße sind in mm angegeben. Verwendete Kommas in Zahlenwerten bezeichnen Dezimalpunkte.

The following applies to all products named in this publication:

1. Some parts of this publication contain statements about the suitability of our products for certain areas of application. These statements are based on our knowledge of typical requirements that are often placed on our products in the areas of application concerned. We nevertheless expressly point out that such statements cannot be regarded as binding statements about the suitability of our products for a particular customer application. As a rule, EPCOS is either unfamiliar with individual customer applications or less familiar with them than the customers themselves. For these reasons, it is always ultimately incumbent on the customer to check and decide whether an EPCOS product with the properties described in the product specification is suitable for use in a particular customer application.
2. We also point out that in individual cases, a malfunction of electronic components or failure before the end of their usual service life cannot be completely ruled out in the current state of the art, even if they are operated as specified. In customer applications requiring a very high level of operational safety and especially in customer applications in which the malfunction or failure of an electronic component could endanger human life or health (e.g. in accident prevention or lifesaving systems), it must therefore be ensured by means of suitable design of the customer application or other action taken by the customer (e.g. installation of protective circuitry or redundancy) that no injury or damage is sustained by third parties in the event of malfunction or failure of an electronic component.
3. The warnings, cautions and product-specific notes must be observed.
4. In order to satisfy certain technical requirements, some of the products described in this publication may contain substances subject to restrictions in certain jurisdictions (e.g. because they are classed as hazardous). Useful information on this will be found in our Material Data Sheets on the Internet ([www.epcos.com/material](http://www.epcos.com/material)). Should you have any more detailed questions, please contact our sales offices.
5. We constantly strive to improve our products. Consequently, the products described in this publication may change from time to time. The same is true of the corresponding product specifications. Please check therefore to what extent product descriptions and specifications contained in this publication are still applicable before or when you place an order. We also reserve the right to discontinue production and delivery of products. Consequently, we cannot guarantee that all products named in this publication will always be available. The aforementioned does not apply in the case of individual agreements deviating from the foregoing for customer-specific products.
6. Unless otherwise agreed in individual contracts, all orders are subject to the current version of the "General Terms of Delivery for Products and Services in the Electrical Industry" published by the German Electrical and Electronics Industry Association (ZVEI).
7. The trade names EPCOS, BAOKE, Alu-X, CeraDiode, CeraLink, CSMP, CSSP, CTVS, DeltaCap, DigiSiMic, DSSP, FilterCap, FormFit, MiniBlue, MiniCell, MKD, MKK, MLSC, MotorCap, PCC, PhaseCap, PhaseCube, PhaseMod, PhiCap, SIFERRIT, SIFI, SIKOREL, SilverCap, SIMDAD, SiMic, SIMID, SineFormer, SIOV, SIP5D, SIP5K, ThermoFuse, WindCap are trademarks registered or pending in Europe and in other countries. Further information will be found on the Internet at [www.epcos.com/trademarks](http://www.epcos.com/trademarks).