

Distance sensors

OADM 20I6580/S14F

dimension drawing

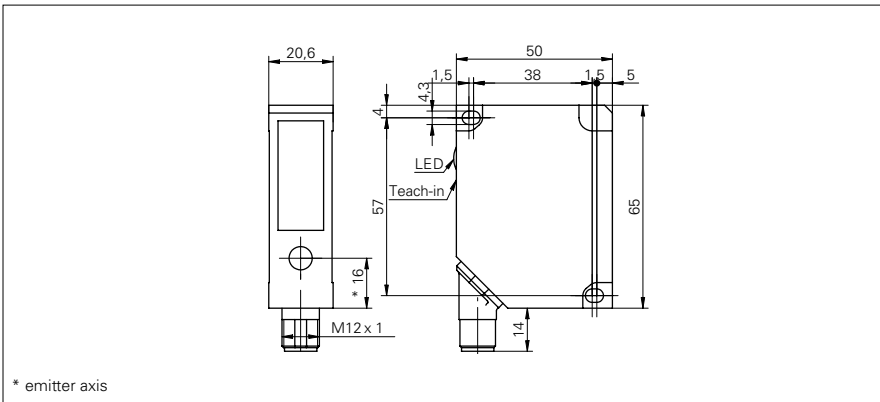

general data

measuring distance Sd	100 ... 600 mm
adjustment	Teach-in: button / external
Teach-in range min.	> 10 mm
power on indication	LED green
soiled lens indicator	LED red
resolution	0,015 ... 0,67 mm
linearity error	± 0,05 ... ± 2 mm
light source	pulsed red laser diode
wave length	650 nm
laser class	2
beam type	line
beam width	2,5 mm
beam height	5,5 ... 21 mm
temperature drift	< 0,03 % Sde/K

electrical data

response time / release time	< 0,9 ms
voltage supply range +Vs	12 ... 28 VDC
current consumption max. (no load)	100 mA
output circuit	analog
output signal	4 ... 20 mA / 0 ... 10 VDC
load resistance (analog I)	< (+Vs - 6 V) / 0,02 A
load resistance (analog U)	> 100 kOhm
output current	< 100 mA
alarm output	PNP
short circuit protection	yes
reverse polarity protection	yes, Vs to GND

mechanical data

width / diameter	20,6 mm
height / length	65 mm
depth	50 mm
type	rectangular
housing material	die-cast zinc
front (optics)	glass
connection types	connector M12 8 pin, rotatable

photo



connection diagram

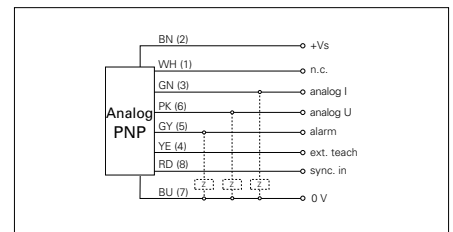

alignment of the laser line



## Distance sensors

## OADM 20I6580/S14F

**ambient conditions**

ambient light immunity	< 10 kLux
operating temperature	0 ... +50 °C
protection class	IP 67

**laser warning**

**LASER RADIATION**  
**DO NOT STARE INTO BEAM**  
Wavelength: 620...690nm  
Max. av. Output: < 1mW  
IEC 60825-1, Ed. 2, 2007  
**CLASS 2 LASER PRODUCT**

Complies with 21 CFR 1040.10 and 1040.11 except for deviations pursuant to laser notice No. 50, dated June 24, 2007