

Distance sensors

OADM 13U6475/S35A

dimension drawing

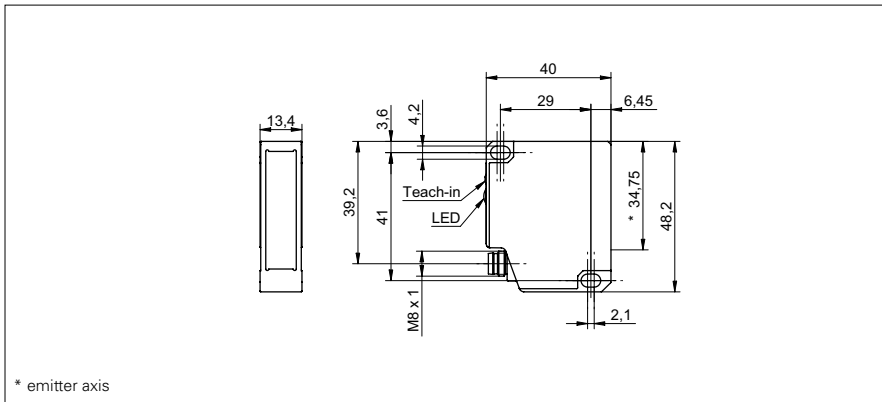

general data

measuring distance Sd	50 ... 350 mm
adjustment	Teach-in: button / external
Teach-in range min.	> 5 mm
power on indication	LED green
soiled lens indicator	LED red
resolution	0,01 ... 0,4 mm
linearity error	± 0,05 ... ± 1,2 mm
light source	pulsed red laser diode
wave length	650 nm
laser class	2
beam type	point
beam diameter	1 mm
interference suppression	< 30 ms
temperature drift	< 0,04 % Sde/K

photo



electrical data

response time / release time	< 0,9 ms
voltage supply range +Vs	12 ... 28 VDC
current consumption max. (no load)	80 mA
output circuit	analog
output signal	0 ... 10 VDC
load resistance	> 100 kOhm
short circuit protection	yes
reverse polarity protection	yes, Vs to GND

connection diagram

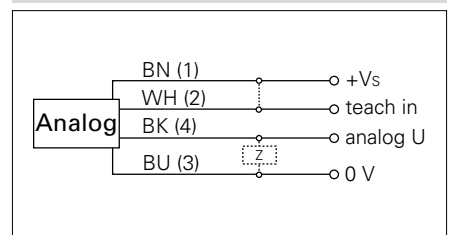

mechanical data

width / diameter	13,4 mm
height / length	48,2 mm
depth	40 mm
type	rectangular
housing material	aluminum
front (optics)	glass
connection types	connector M8 4 pin

laser warning

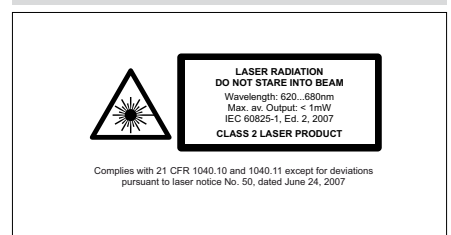

**Distance sensors****OADM 13U6475/S35A****ambient conditions**

ambient light immunity	< 20 kLux
operating temperature	0 ... +50 °C
protection class	IP 67