

Distance sensors

OADM 13I7580/S35A

dimension drawing

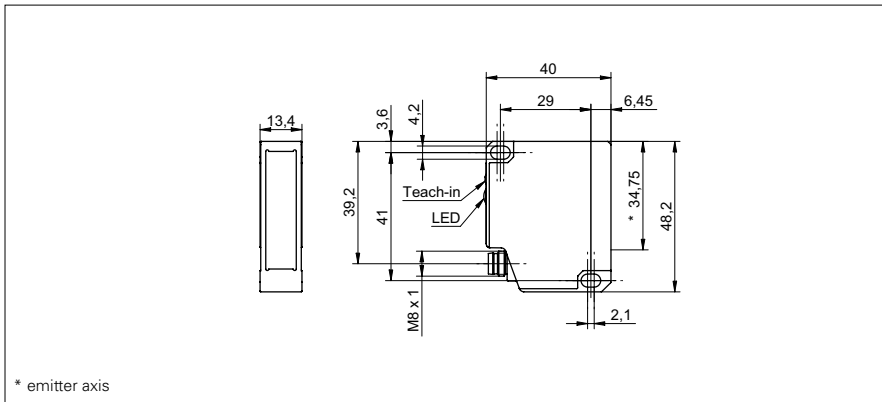

general data

measuring distance Sd	50 ... 550 mm
adjustment	Teach-in: button / external
Teach-in range min.	> 10 mm
power on indication	LED green
soiled lens indicator	LED red
resolution	0,01 ... 1,15 mm
linearity error	± 0,08 ... ± 3,5 mm
light source	pulsed red laser diode
wave length	650 nm
laser class	2
beam type	line
beam width	2 ... 1 mm
beam height	4 ... 11 mm
interference suppression	< 30 ms
temperature drift	< 0,07 % Sde/K

photo



electrical data

response time / release time	< 2 ms
voltage supply range +Vs	12 ... 28 VDC
current consumption max. (no load)	100 mA
output circuit	analog
output signal	4 ... 20 mA
load resistance	< (+Vs - 6 V) / 0,02 A
short circuit protection	yes
reverse polarity protection	yes, Vs to GND

connection diagram

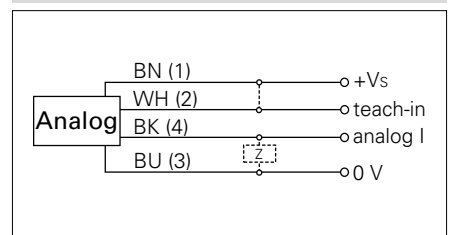

mechanical data

width / diameter	13,4 mm
height / length	48,2 mm
depth	40 mm
type	rectangular
housing material	aluminum
front (optics)	glass
connection types	connector M8 4 pin

laser warning

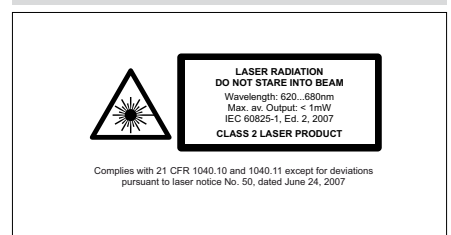

**Distance sensors****OADM 13I7580/S35A****ambient conditions**

ambient light immunity	< 40 kLux
operating temperature	0 ... +50 °C
protection class	IP 67