



## **SAW Components**

### **SAW Duplexer**

LTE Band 20

<b>Series/type:</b>	<b>B7679</b>
<b>Ordering code:</b>	<b>B39851B7679A710</b>
<b>Date:</b>	<b>December 14, 2010</b>
<b>Version:</b>	<b>2.0</b>



Data sheet



Application

- Low-loss SAW duplexer for LTE Band 20 systems
- Low insertion attenuation
- Low amplitude ripple
- Usable passband 30 MHz
- Single-ended to balanced transformation in Antenna-Rx path
- Impedance transformation 50 Ω to 100 Ω in Antenna-Rx path
- Very small size and low height

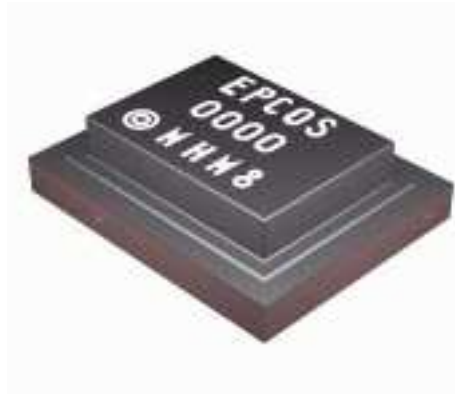

Features

- Package size 2.5 \* 2.0 \* 0.68 mm<sup>3</sup>
- RoHS compatible
- Approximate weight 0.013 g
- Package for **Surface Mount Technology (SMT)**
- Ni, Au-plated terminals
- **Electrostatic Sensitive Device (ESD)**
- Moisture Sensitivity Level 3

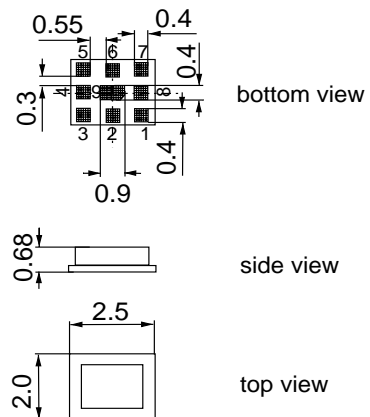

Pin configuration

- 3 Tx input
- 1, 8 Rx output (balanced)
- 6 Antenna
- 2, 4, 5, 7, 9 To be grounded

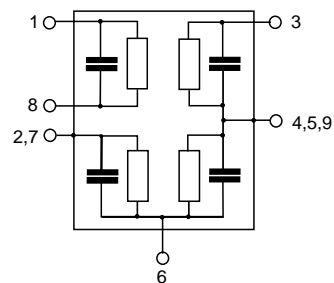



Data sheet



**Characteristics**

Temperature range for specification: T = -30 °C to +85 °C  
 TX terminating impedance: Z<sub>Tx</sub> = 50 Ω  
 ANT terminating impedance: Z<sub>Ant</sub> = 50 Ω || 8.2 nH  
 RX terminating impedance: Z<sub>Rx</sub> = 100 Ω (balanced) || 56 nH

Characteristics Tx-Antenna		min.	typ. @ 25 °C	max.	
<b>Center frequency</b>	f <sub>c</sub>		847.0		MHz
<b>Maximum insertion attenuation</b>	α				<b>CTQ</b>
832.1 ... 861.9 MHz <sup>1)</sup>			2.7	3.0	dB
836.1 ... 857.9 MHz			2.2	2.9	dB
832.1 ... 861.9 MHz			2.7	3.4	dB
<b>Amplitude ripple (p-p)</b>	Δα				
832.1 ... 861.9 MHz <sup>2)</sup>			1.4	1.8	dB
832.1 ... 861.9 MHz			1.4	2.2	dB
<b>Error Vector Magnitude</b>	EVM				
5 MHz Channel @ f <sub>Carrier</sub> 834.6...859.4MHz <sup>3)</sup>			2.6	6.0	%
20 MHz Channel @ f <sub>Carrier</sub> 842.1...851.9MHz <sup>4)</sup>			10	16	%
<b>Input VSWR (Tx port)</b>					
832.0 ... 862.0 MHz			1.8	2.1	
<b>Output VSWR (Ant Port)</b>					
832.0 ... 862.0 MHz			1.9	2.1	

1) in 0C-60C temperature range  
 2) in 0C-60C temperature range  
 3) Computed with 4 MHz square signal  
 4) Computed with 18 MHz square signal



Data sheet



Characteristics Tx-Antenna

				min.	typ. @ 25 °C	max.	
<b>Absolute attenuation</b>							
			$\alpha$				
	0.3 ...	791.0	MHz	35	38		dB
	791.1 ...	820.0	MHz	45	52		dB
	820.0 ...	820.9	MHz	43	60		dB
	873.0 ...	875.0	MHz	15	45		dB
	875.0 ...	903.0	MHz	35	50		dB
	1560.0 ...	1590.0	MHz	30	55		dB
	1654.0 ...	1734.0	MHz	35	55		dB
	2400.0 ...	2483.0	MHz	30	40		dB
	2476.0 ...	2606.0	MHz	30	40		dB
	3298.0 ...	3478.0	MHz	30	38		dB
	4000.0 ...	4500.0	MHz	20	30		dB
	4500.0 ...	5000.0	MHz	10	20		dB
	5000.0 ...	6000.0	MHz	5	12		dB



Data sheet



Characteristics

Temperature range for specification: T = -30°C to +85 °C  
 TX terminating impedance: Z<sub>Tx</sub> = 50 Ω  
 ANT terminating impedance: Z<sub>Ant</sub> = 50 Ω || 8.2 nH  
 RX terminating impedance: Z<sub>Rx</sub> = 100 Ω (balanced) || 56 nH

Characteristics Antenna-Rx		min.	typ. @ 25 °C	max.	
<b>Center frequency</b>	f <sub>c</sub>		806.0		MHz
<b>Maximum insertion attenuation</b>	α				<b>CTQ</b>
791.1 ... 793.0 MHz <sup>1)</sup>			2.6	4.0	dB
793.0 ... 820.9 MHz <sup>2)</sup>			2.6	3.5	dB
791.1 ... 820.9 MHz			2.6	4.0	dB
<b>Amplitude ripple</b>	α				
791.1 ... 820.9 MHz <sup>3)</sup>			1.4	2.7	dB
791.1 ... 820.9 MHz			1.4	2.7	dB
<b>Error Vector Magnitude</b>					
5 MHz Channel @ f <sub>Carrier</sub>					
793.6 ... 818.4 MHz <sup>4)</sup>			3.1	8	%
20 MHz Channel @ f <sub>Carrier</sub>					
801.1 ... 810.9 MHz <sup>5)</sup>			6.2	16	%
<b>Input VSWR (Ant port)</b>					
791.0 ... 821.0 MHz			1.7	2.1	
<b>Output VSWR (Rx Port)</b>					
791.0 ... 821.0 MHz			1.8	2.1	
<b>Common mode rejection ratio</b>					
791.0 ... 821.0 MHz		23	25		dB

1) in 0C-60C temperature range  
 2) in 0C-60C temperature range  
 3) in 0C-60C temperature range  
 4) Computed with 5 MHz square signal  
 5) Computed with 18 MHz square signal



Data sheet



Characteristics Antenna-Rx				min.	typ. @ 25 °C	max.	
<b>Absolute attenuation</b>			$\alpha$				
	0.3 ... 750.0	MHz		40	53		dB
	832.1 ... 833.0	MHz		41	50		dB
	833.0 ... 862.0	MHz		47	51		dB
	873.0 ... 903.0	MHz		41	48		dB
	1000.0 ... 3000.0	MHz		40	50		dB
	3000.0 ... 6000.0	MHz		30	45		dB

Characteristics Tx-Rx				min.	typ. @ 25 °C	max.	
<b>Differential mode isolation</b>			$\alpha$				
	791.1 ... 820.0	MHz		48	54		dB
	820.0 ... 820.9	MHz		46	58		dB
	832.1 ... 833.0	MHz		47	55		dB
	833.0 ... 861.9	MHz		49	55		dB
<b>Common mode isolation</b>			$\alpha$				
	832.1 ... 861.9	MHz		53	63		dB



**SAW Components**

**B7679**

**SAW Duplexer**

**847.0 / 806.0 MHz**

Data sheet



**Maximum Ratings**

Storage temperature range	$T_{stg}$	-40/+85	°C	
DC voltage	$V_{DC}$	5	V	
ESD voltage	$V_{ESD}$	500 <sup>1)</sup>	V	CD model, 3 pulses
ESD voltage	$V_{ESD}$	250 <sup>2)</sup>	V	HB model, 1 pulse
ESD voltage	$V_{ESD}$	100 <sup>3)</sup>	V	M model, 1 pulse
Input power at Tx Port				
834.5 ...859.5 MHz	$P_{in}$	28	dBm	} LTE uplink signal 55 °C, 50000h
elsewhere	$P_{in}$	10	dBm	

1) According to JESD22-C101 (Charged Device model), 3 negative and 3 positive pulses.

2) According to JESD22-A114E (Human Body model), 1 negative and 1 positive pulses.

3) According to JESD22-A115A (Machine model), 1 negative and 1 positive pulses.

**Matching network (element values depend on PCB layout)**

Lp1 = 8.2 nH, Lp2 = 56 nH

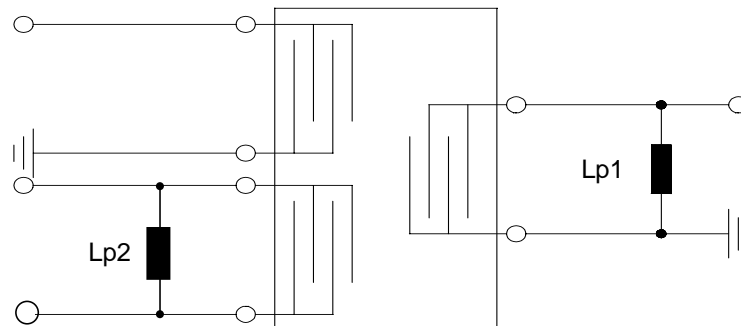



Frequency Response TX-ANT

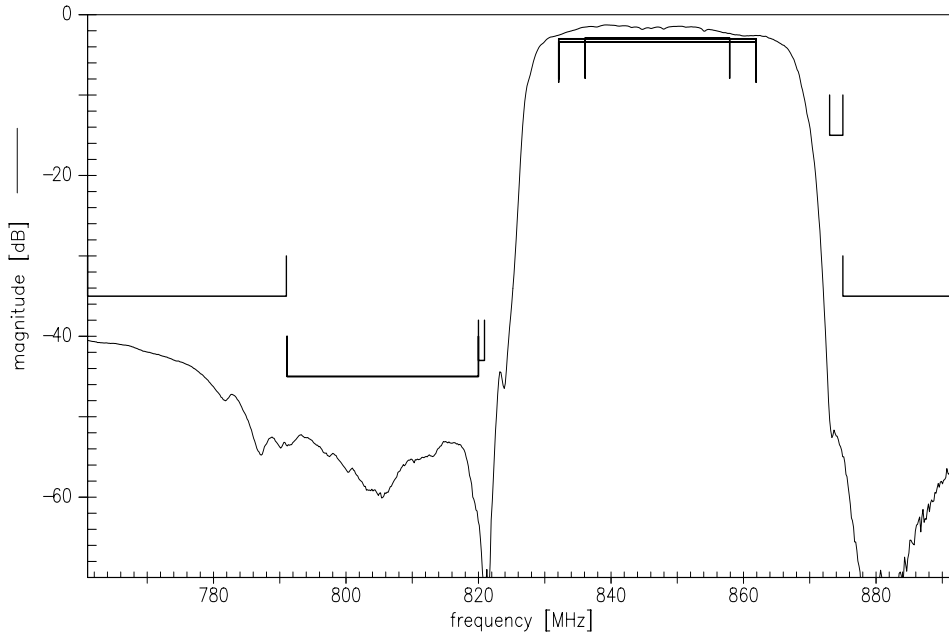

Frequency Response TX-ANT

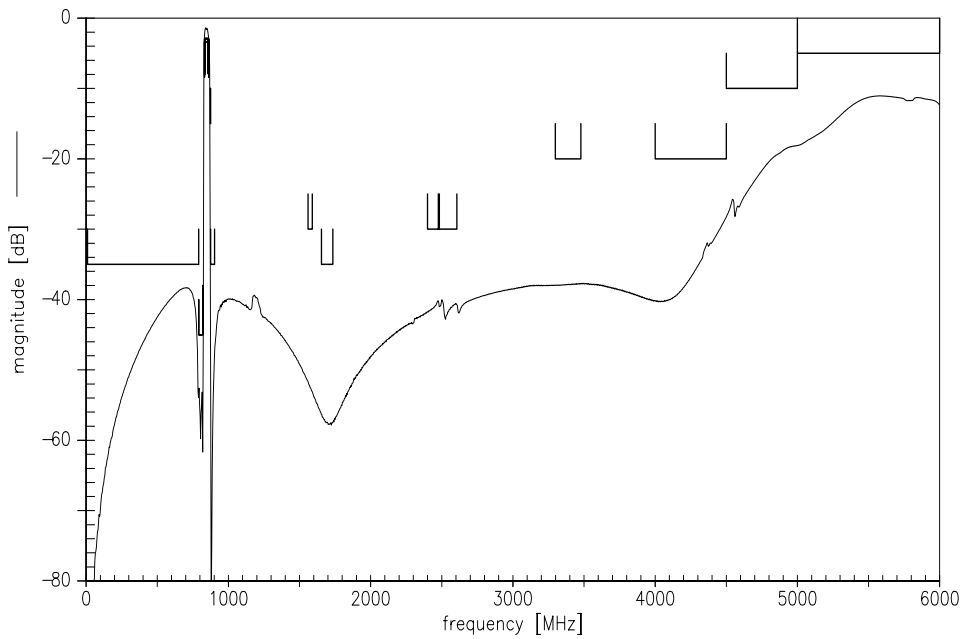



Frequency Response ANT-RX

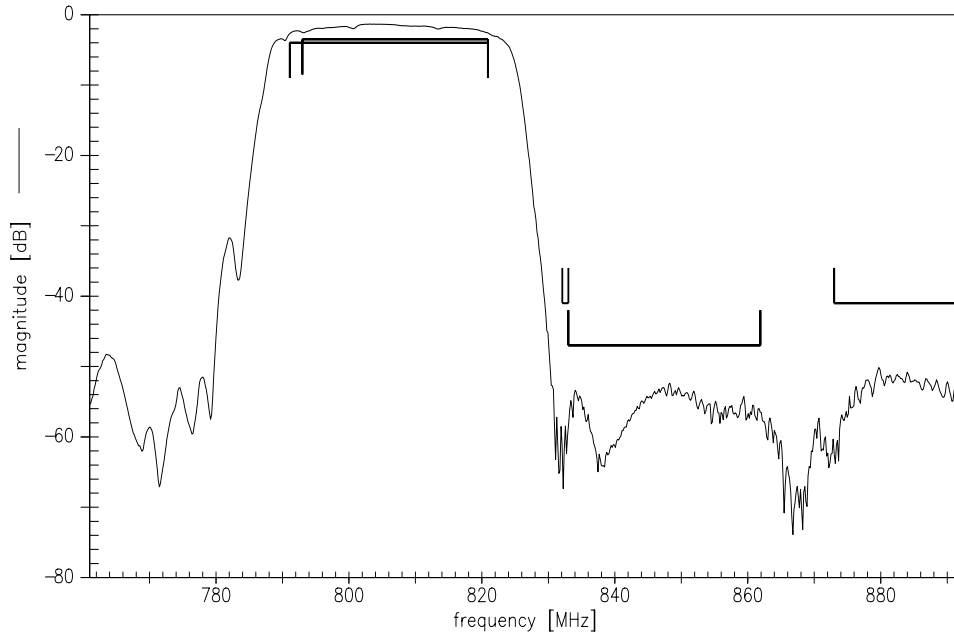

Frequency Response ANT-RX

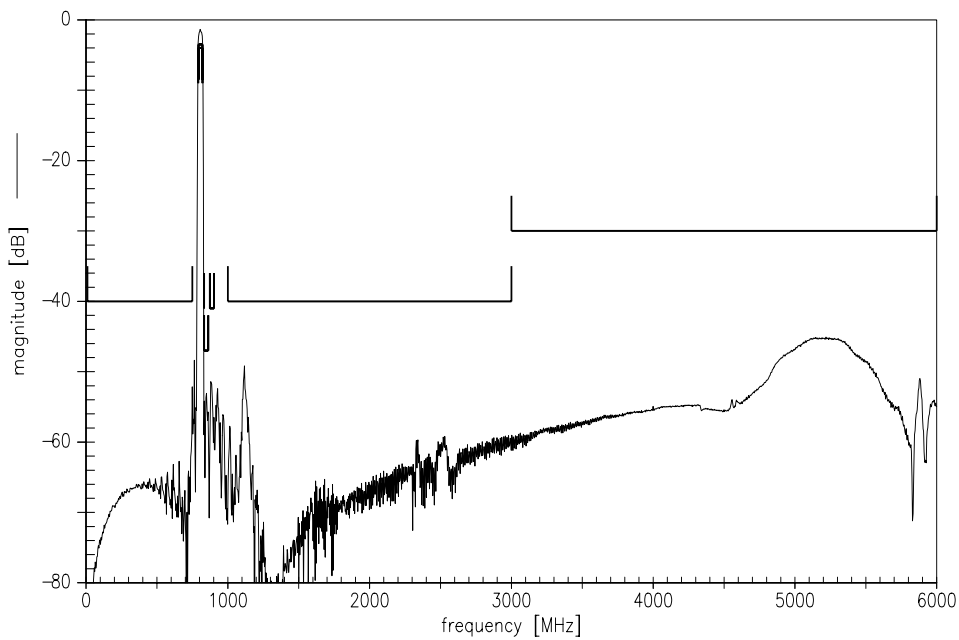



Frequency Response TX-RX

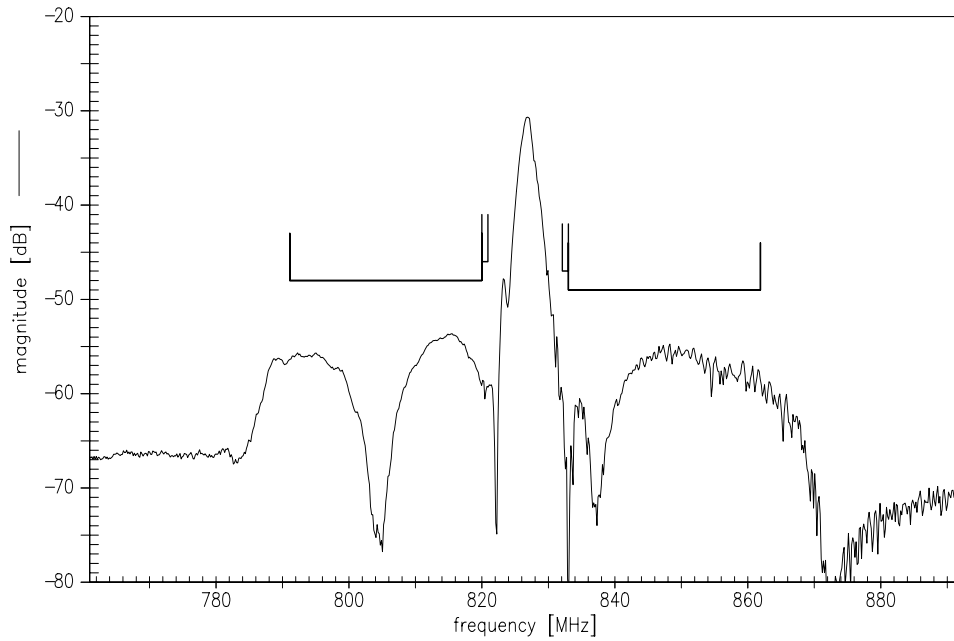

Frequency Response TX-RX

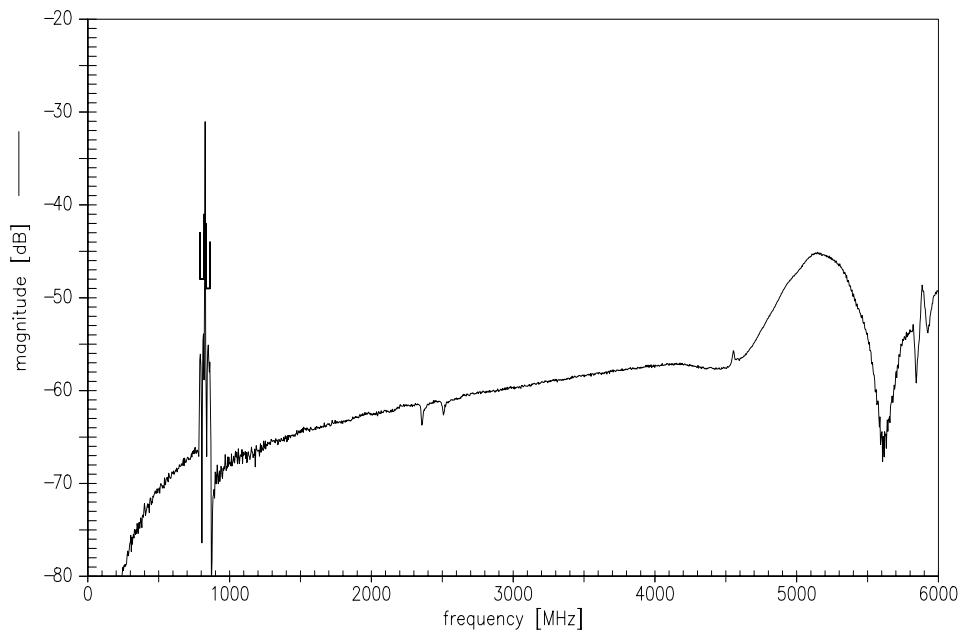



Data sheet



**S11 VSWR (TX)**

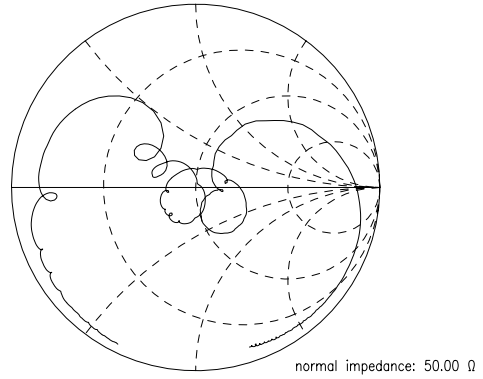
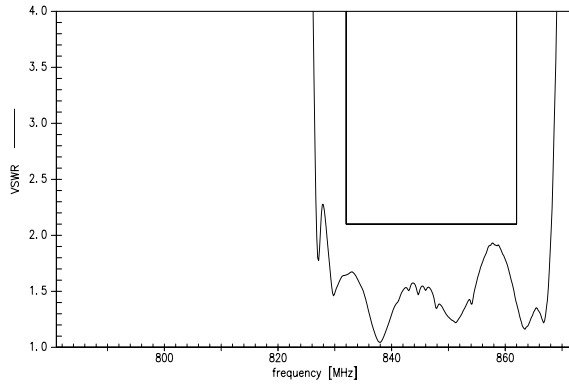

**S22 VSWR (ANT)**

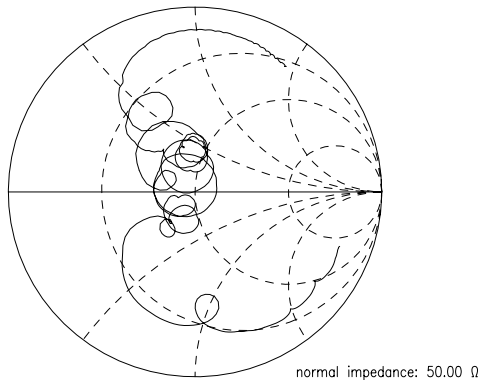
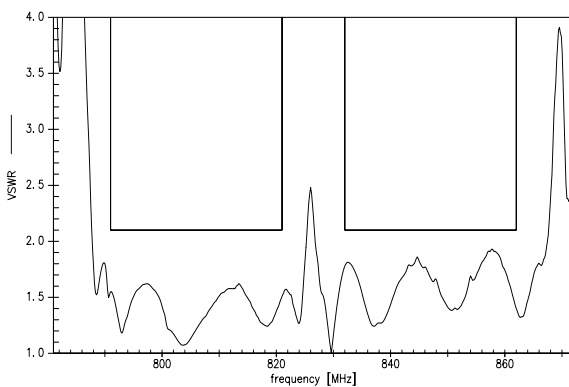

**S33 VSWR (RX)**

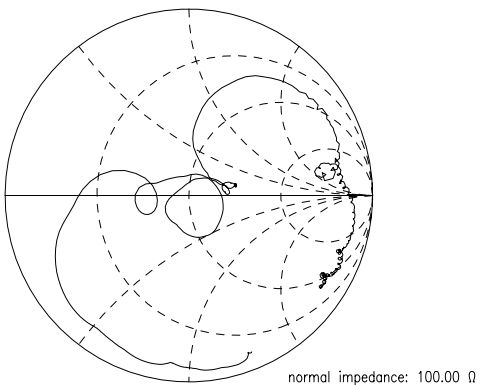
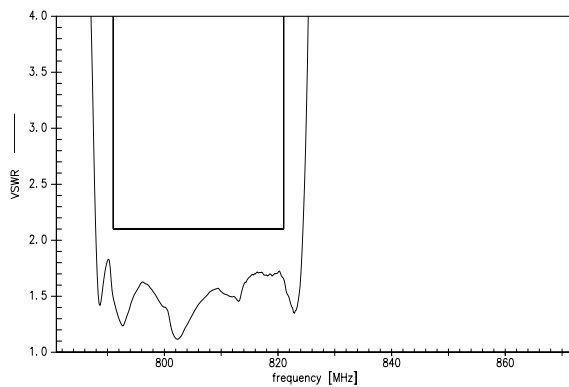

**SAW Components****B7679****SAW Duplexer****847.0 / 806.0 MHz**

Data sheet



References

<b>Type</b>	B7679
<b>Ordering code</b>	B39851B7679A710
<b>Marking and package</b>	C61157-A3-A61
<b>Packaging</b>	F611074-V8153-Z000
<b>Date codes</b>	L_1126
<b>S-parameters</b>	B7679_NB.S4P B7679_WB.S4P
<b>Soldering profile</b>	S_6001
<b>RoHS compatible</b>	Defined as compatible with the following documents: "DIRECTIVE 2002/95/EC OF THE EUROPEAN PARLIAMENT AND OF THE COUNCIL of 27 January 2003 on the restriction of the use of certain hazardous substances in electrical and electronic equipment. 2005/618/EC from April 18th, 2005, amending Directive 2002/95/EC of the European Parliament and of the Council for the purposes of establishing the maximum concentration values for certain hazardous substances in electrical and electronic equipment."
<b>Matching coils</b>	See Inductor pdf-catalog <a href="http://www.tdk.co.jp/tefe02/coil.htm#aname1">http://www.tdk.co.jp/tefe02/coil.htm#aname1</a> and Data Library for circuit simulation <a href="http://www.tdk.co.jp/etvcl/index.htm">http://www.tdk.co.jp/etvcl/index.htm</a>

For further information please contact your local EPCOS sales office or visit our webpage at [www.epcos.com](http://www.epcos.com).

**Published by EPCOS AG**  
**Surface Acoustic Wave Components Division**  
**P.O. Box 80 17 09, 81617 Munich, GERMANY**

© EPCOS AG 2010. This brochure replaces the previous edition.

For questions on technology, prices and delivery please contact the Sales Offices of EPCOS AG or the international Representatives.

Due to technical requirements components may contain dangerous substances. For information on the type in question please also contact one of our Sales Offices.

Please read *cautions and warnings and important notes* at the end of this document.



## Important notes

The following applies to all products named in this publication:

1. Some parts of this publication contain **statements about the suitability of our products for certain areas of application**. These statements are based on our knowledge of typical requirements that are often placed on our products in the areas of application concerned. We nevertheless expressly point out **that such statements cannot be regarded as binding statements about the suitability of our products for a particular customer application**. As a rule, EPCOS is either unfamiliar with individual customer applications or less familiar with them than the customers themselves. For these reasons, it is always ultimately incumbent on the customer to check and decide whether an EPCOS product with the properties described in the product specification is suitable for use in a particular customer application.
2. We also point out that **in individual cases, a malfunction of electronic components or failure before the end of their usual service life cannot be completely ruled out in the current state of the art, even if they are operated as specified**. In customer applications requiring a very high level of operational safety and especially in customer applications in which the malfunction or failure of an electronic component could endanger human life or health (e.g. in accident prevention or life-saving systems), it must therefore be ensured by means of suitable design of the customer application or other action taken by the customer (e.g. installation of protective circuitry or redundancy) that no injury or damage is sustained by third parties in the event of malfunction or failure of an electronic component.
3. **The warnings, cautions and product-specific notes must be observed.**
4. In order to satisfy certain technical requirements, **some of the products described in this publication may contain substances subject to restrictions in certain jurisdictions (e.g. because they are classed as hazardous)**. Useful information on this will be found in our Material Data Sheets on the Internet ([www.epcos.com/material](http://www.epcos.com/material)). Should you have any more detailed questions, please contact our sales offices.
5. We constantly strive to improve our products. Consequently, **the products described in this publication may change from time to time**. The same is true of the corresponding product specifications. Please check therefore to what extent product descriptions and specifications contained in this publication are still applicable before or when you place an order.  
We also **reserve the right to discontinue production and delivery of products**. Consequently, we cannot guarantee that all products named in this publication will always be available. The aforementioned does not apply in the case of individual agreements deviating from the foregoing for customer-specific products.
6. Unless otherwise agreed in individual contracts, **all orders are subject to the current version of the "General Terms of Delivery for Products and Services in the Electrical Industry" published by the German Electrical and Electronics Industry Association (ZVEI)**.
7. The trade names EPCOS, BAOKE, Alu-X, CeraDiode, CSMP, CSSP, CTVS, DeltaCap, DigiSiMic, DSSP, FormFit, MiniBlue, MiniCell, MKD, MKK, MLSC, MotorCap, PCC, PhaseCap, PhaseCube, PhaseMod, PhiCap, SIFERRIT, SIFI, SIKOREL, SilverCap, SIMDAD, SiMic, SIMID, SineFormer, SIOV, SIP5D, SIP5K, ThermoFuse, WindCap are **trademarks registered or pending** in Europe and in other countries. Further information will be found on the Internet at [www.epcos.com/trademarks](http://www.epcos.com/trademarks).