



Film capacitors – Power Factor Correction

Key components – Thyristor module TSM

Series/Type: TSM-HV50
Ordering code: B44066T0050E690
Date: July 2012
Version: 9

Characteristics

- Fast electronically controlled self observing thyristor switch
- Usage in dynamic (fast) power factor correction systems in 690 V grids, **neutral conductor required**
- For capacitive loads up to max. 60 kvar at 690 V
- Micro-processor controlled alignment to tuned or de-tuned capacitor branches (up to 14%) for optimized switching behavior
- No system perturbation due to switching operations (transients)
- Switching without delay
- Maintenance-free
- Long useful service life
- No noise emission during switching operations
- Compact module ready for connection



Technical data and specifications

Dimensions (w × h × d)	157 × 200 × 195 mm
Weight	5 kg
Rated voltage	690 V
Maximum voltage	
- in conventional PFC-systems (without reactors)	690 V +/-10%
- in detuned PFC-systems (7% detuning)	690 V +/-10%
- in detuned PFC-systems (14% detuning)	690 V +/-10%
Frequency	50/60 Hz
Maximum power	60 kvar
Auxiliary supply	230 V AC
Activation	10 ... 24 V DC (approx. 20 mA) via terminal clamp, internally electrically isolated
Monitoring	Grid voltage, temperature and operation status Note: Before re-switching after temperature fault, heat sink temperature must be below +50 °C (hysteresis!)
Display	1 status LED per phase: operation/fault and over temperature, 1 LED: triggering signal
Switching time	Approx. 5 ms
Reset time	Depending on degree of detuning and dimension of discharge resistor
Power circuit	Direct connection 4 pole via bus bar cable lug max. 25 mm ² , D = 8 mm
Power dissipation	P_D (in W) = 3.0 × I (in A); at 690 V/50 kvar approx. 125W thermal Note: Ensure proper air convection; forced cooling inside the panel (switchboard)
Fuses (mandatory for protection of components)	3 × electronic fuse „superfast“ NH00 AC 690 V 50/60 kvar: max. 100 A (e.g. SIBA Art.No. 20 209 20-100) 25 kvar: max. 63 A (e.g. SIBA Art.No. 20 477 20-63)
Ambient operating temperature at nominal load	-10 °C ... +55 °C
Mounting position	Vertical; minimum 100 mm distance upwards and downwards
Assembling	Directly on mounting plate

Dimensional drawing

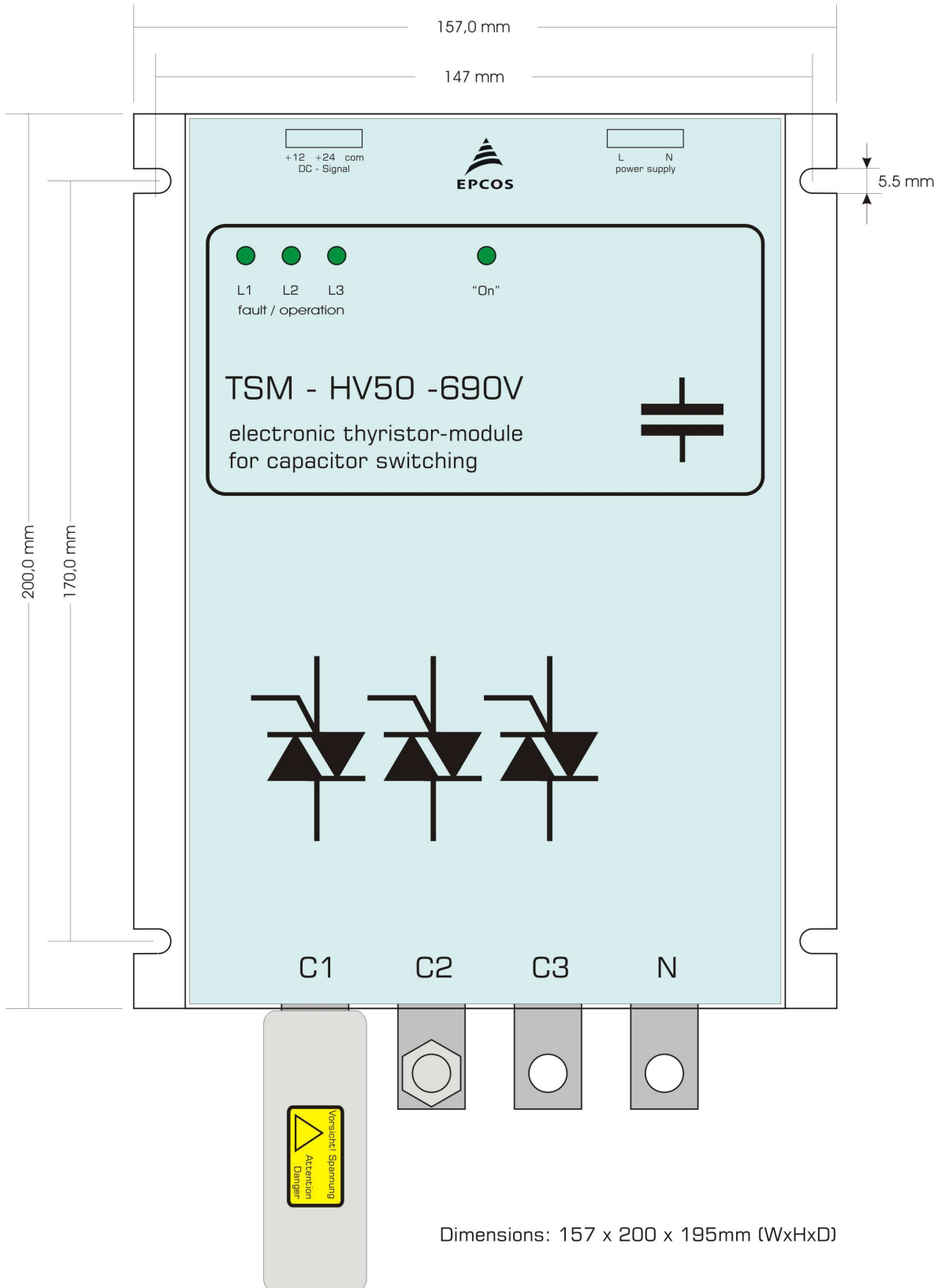

Connection diagram
(three-phase standard)

GRID 3x 690V

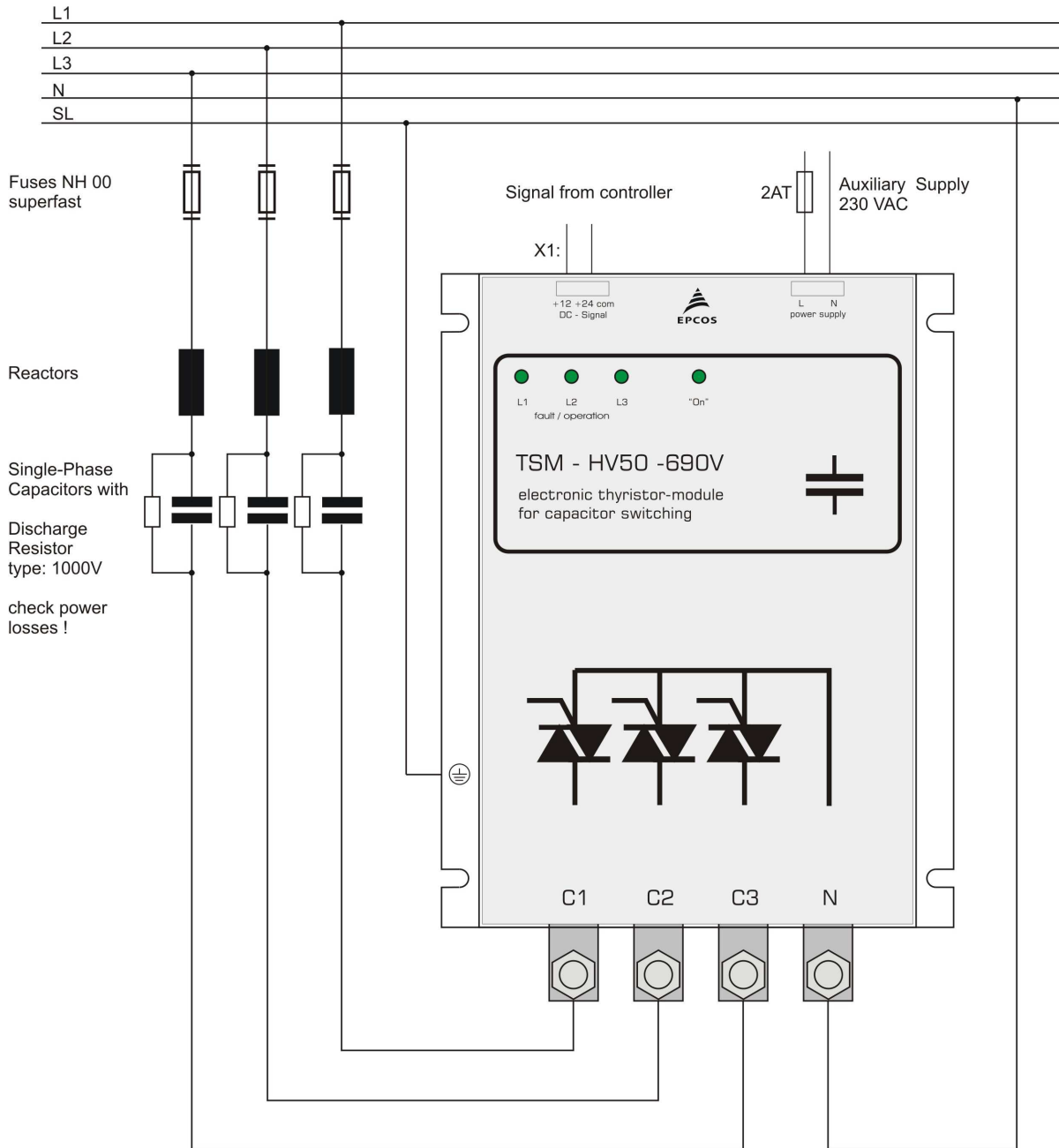

Cautions and Warnings

General

- Thyristor modules TSM series may only be used for the purpose they have been designed for.
- Thyristor modules TSM series may only be used in combination with appropriate pre-switched grid separator device.
- Thyristor modules have to be projected in such a way that in case of any failure no uncontrolled high current and voltages may occur.
- The devices in operation have to be protected against moisture and dust, sufficient cooling has to be assured.

Attention

Due to the switching principle of the thyristor module the power capacitors are permanently loaded to the peak value of the grid voltage (DC voltage) even when switched off. Therefore following rules have to be obeyed in any case:

- For standard PFC-systems (without reactors) power capacitors of 440 V nominal voltage have to be used; for detuned systems PFC capacitors of 480 V nominal voltage have to be used.
- Due to the 3-phase switching of the TSM-HV50, standard resistors are sufficient.
- In dynamic systems with TSM modules no fast discharge reactors may be used (reactor = DC-wise short circuit).
- Thyristor modules in general have to be protected by superfast electronic fuses. Principles for dimensioning have to be considered. Fuses in the system have to be marked.
- Due to the special switching, the PFC capacitors are fully loaded even when the particular step has been switched off. Protection against contact has to be guaranteed. Warning signals in the systems are required.
- Even in switched off state no electrical isolation is achieved for electronic switches. Therefore parts of the systems may not be touched after switching off the complete system before the capacitors have been completely discharged.

FAILURE TO FOLLOW CAUTIONS MAY RESULT, WORST CASE, IN PREMATURE FAILURES OR PHYSICAL INJURY.

Note

For detailed information about PFC capacitors and cautions, refer to the latest version of EPCOS PFC Product Profile.

Important notes

The following applies to all products named in this publication:

1. Some parts of this publication contain **statements about the suitability of our products for certain areas of application**. These statements are based on our knowledge of typical requirements that are often placed on our products in the areas of application concerned. We nevertheless expressly point out **that such statements cannot be regarded as binding statements about the suitability of our products for a particular customer application**. As a rule, EPCOS is either unfamiliar with individual customer applications or less familiar with them than the customers themselves. For these reasons, it is always ultimately incumbent on the customer to check and decide whether an EPCOS product with the properties described in the product specification is suitable for use in a particular customer application.
2. We also point out that **in individual cases, a malfunction of electronic components or failure before the end of their usual service life cannot be completely ruled out in the current state of the art, even if they are operated as specified**. In customer applications requiring a very high level of operational safety and especially in customer applications in which the malfunction or failure of an electronic component could endanger human life or health (e.g. in accident prevention or life-saving systems), it must therefore be ensured by means of suitable design of the customer application or other action taken by the customer (e.g. installation of protective circuitry or redundancy) that no injury or damage is sustained by third parties in the event of malfunction or failure of an electronic component.
3. **The warnings, cautions and product-specific notes must be observed.**
4. In order to satisfy certain technical requirements, **some of the products described in this publication may contain substances subject to restrictions in certain jurisdictions (e.g. because they are classed as hazardous)**. Useful information on this will be found in our Material Data Sheets on the Internet (www.epcos.com/material). Should you have any more detailed questions, please contact our sales offices.
5. We constantly strive to improve our products. Consequently, **the products described in this publication may change from time to time**. The same is true of the corresponding product specifications. Please check therefore to what extent product descriptions and specifications contained in this publication are still applicable before or when you place an order. We also **reserve the right to discontinue production and delivery of products**. Consequently, we cannot guarantee that all products named in this publication will always be available. The aforementioned does not apply in the case of individual agreements deviating from the foregoing for customer-specific products.
6. Unless otherwise agreed in individual contracts, **all orders are subject to the current version of the "General Terms of Delivery for Products and Services in the Electrical Industry" published by the German Electrical and Electronics Industry Association (ZVEI)**.
7. The trade names EPCOS, BAOKE, Alu-X, CeraDiode, CeraLink, CSMP, CSSP, CTVS, DeltaCap, DigiSiMic, DSSP, FilterCap, FormFit, MiniBlue, MiniCell, MKD, MKK, MLSC, MotorCap, PCC, PhaseCap, PhaseCube, PhaseMod, PhiCap, SIFERRIT, SIFI, SIKOREL, SilverCap, SIMDAD, SiMic, SIMID, SineFormer, SIOV, SIP5D, SIP5K, ThermoFuse, WindCap are **trademarks registered or pending** in Europe and in other countries. Further information will be found on the Internet at www.epcos.com/trademarks.