

2 x 75A Dual Channel Brushless DC Motor Controller



Roboteq's VBL2350 is a high-current, dual channel controller for hall-sensor equipped Brushless DC motors. The controller uses the position information from the sensors to sequence power on the motors' 3 windings in order to generate smooth continuous rotation. The controller also uses the Hall sensor information to compute speed and measure travelled distance inside a 32-bit counter. The motors may be operated in open or closed loop speed mode. Using low-cost position sensors, they may also be set to operate as heavy-duty position servos.

The VBL2350 accepts commands received from an RC radio, Analog Joystick, wireless modem, or microcomputer. For mobile robot applications, the controller's two motor channels can either be operated independently or mixed to set the direction and rotation of a vehicle by coordinating the motion of each motor.

Numerous safety features are incorporated into the controller to ensure reliable and safe operation. The controller's operation can be extensively automated and customized using Basic Language scripts. The controller can be configured, monitored and tuned in realtime using a Roboteq's free PC utility. The controller can also be reprogrammed in the field with the latest features by downloading new operating software from Roboteq.

Applications

- Small Electric Vehicles, Electric Bikes
- Terrestrial and Underwater Robotic Vehicles
- Automatic Guided Vehicles
- Police and Military Robots
- Hazardous Material Handling Robots
- Balancing Robots
- Telepresence Systems
- Animatronics
- Industrial Controls

Key Features

- RS232, 0-5V Analog, or Pulse (RC radio) command modes
- Auto switch between RS232, Analog, or Pulse based on user-defined priority
- Built-in dual 3-phase high-power drivers for two brushless DC motor at up to 75A
- Trapezoidal switching based on Hall Sensor position information
- Full forward & reverse motor control. Four quadrant operation. Supports regeneration
- Operates from a single 10V-50V power source
- Built-in programming language for automation and customization
- Programmable current limit up to 75A for protecting controller, motor, wiring and battery.
- Connector for Hall Sensors
- Accurate speed and Odometry measurement using Hall Sensor data
- Up to 4 Analog Inputs for use as command and/or feedback
- Up to 5 Pulse Length, Duty Cycle or Frequency Inputs for use as command and/or feedback
- Up to 6 Digital Inputs for use as Deadman Switch, Limit Switch, Emergency stop or user inputs
- Two general purpose 24V, 1.5A output for brake release or accessories
- Selectable min, max, center and deadband in Pulse and Analog modes
- Selectable exponentiation factors for each command inputs
- Trigger action if Analog, Pulse or Hall counter capture are outside user selectable range (soft limit switches)
- Open loop or closed loop speed control operation

- Closed loop position control with encoder, analog or pulse/frequency feedback
- PID control loop
- Configurable Data Logging of operating parameters on RS232 Output for telemetry or analysis
- Built-in Battery Voltage and Temperature sensors
- Optional 12V backup power input for powering safely the controller if the main motor batteries are discharged
- Power Control wire for turning On or Off the controller from external microcomputer or switch
- No consumption by output stage when motors stopped
- Regulated 5V output for powering RC radio, RF Modem or microcomputer
- Separate Programmable acceleration and deceleration for each motor
- Ultra-efficient 3 mOhm ON resistance MOSFETs
- Auto stop if no motion is detected
- Stall detection and selectable triggered action if Amps is outside user-selected range
- Short circuit protection with selectable sensitivity levels
- Overvoltage and Undervoltage protection
- Watchdog for automatic motor shutdown in case of command loss
- Overtemperature protection
- Diagnostic LED
- Extruded aluminum, heat sinking enclosure for operation harsh shock and temperature environment
- Efficient heat sinking. Operates without a fan in most applications.
- Dustproof and weather resistant. IP51 NEMA rating
- Power wiring via heavy AWG8 battery cables and AWG10 motor cables
- 9" (228.5mm) L, 5.5" W (140mm), 1.6" (40mm) H
- -40o to +85o C operating environment
- 3 lbs (1,350g)
- Easy configuration, tuning and monitory using provided PC utility
- Field upgradeable software for installing latest features via the internet

Orderable Product References

| Reference | Number of Channels | Amps/Channel | Volts |
|-----------|--------------------|--------------|-------|
| VBL2350 | 2 | 75 | 50 |

Important Safety Disclaimer

Dangerous uncontrolled motor runaway condition can occur for a number of reasons, including, but not limited to: command or feedback wiring failure, configuration error, faulty firmware, errors in user script or user program, or controller hardware failure.

The user must assume that such failures can occur and must make his/her system safe in all conditions. Roboteq will not be liable in case of damage or injury as a result of product misuse or failure.

Power Wires Identifications and Connection

Power connections are made by means of heavy gauge wires located at the back of the controller.

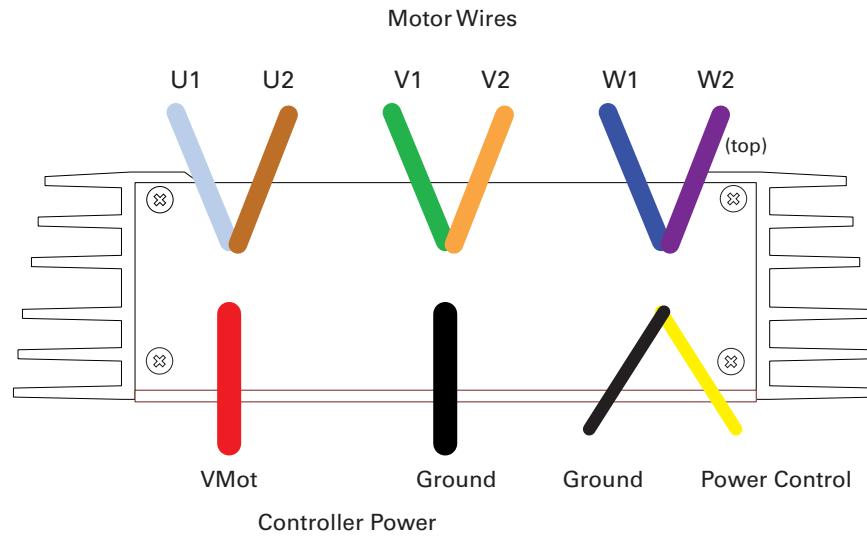

FIGURE 8. Rear Controller Layout

The diagram below shows how to wire the controller and how to turn power On and Off.

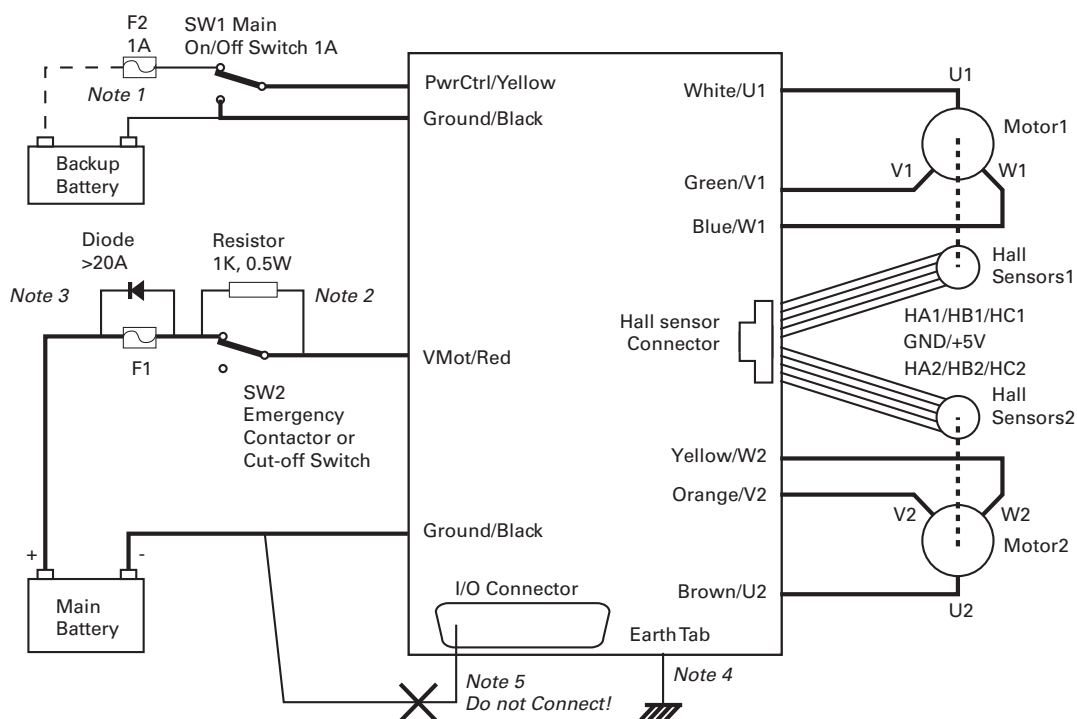

FIGURE 9. Powering the controller. Thick lines identify **MANDATORY** connections

Important Warning

Carefully follow the wiring instructions provided in the Power Connection section of the User Manual. The information on this datasheet is only a summary.

Mandatory Connections

It is imperative that the controller is connected as shown in the above diagram in order to ensure a safe and trouble-free operation. All connections shown as thick black lines are mandatory. The controller must be powered On/Off using switch SW1 on the Yellow wire. Use a suitable high-current fuse F1 as a safety measure to prevent damage to the wiring in case of major controller malfunction.

Emergency Switch or Contactor

The battery must be connected in permanence to the controller's Red wires via a high-power emergency switch or contactor SW2 as additional safety measure. The user must be able to deactivate the switch or contactor at any time, independently of the controller state.

Precautions and Optional Connections

Note1: Backup battery to ensure motor operation with weak or discharged batteries, connect a second battery to the Power Control wire/terminal via the SW1 switch.

Note2: Use precharge 1K, 0.5W Resistor to prevent switch arcing.

Note3: Insert a high-current diode to ensure a return path to the battery during regeneration in case the fuse is blown.

Note4: Optionally ground the VMot wires when the controller is Off if there is any concern that the motors could be made to spin and generate voltage in excess of 50V.

Note5: Connect the controller’s earth tab to a wire connected to the Earth while the charger is plugged in the AC main, or if the controller is powered by an AC power supply.

Note6: Beware not to create a path from the ground pins on the I/O connector and the battery minus terminal.

Use of Safety Contactor for Critical Applications

An external safety contactor must be used in any application where damage to property or injury to person can occur because of uncontrolled motor operation resulting from failure in the controller’s power output stage.

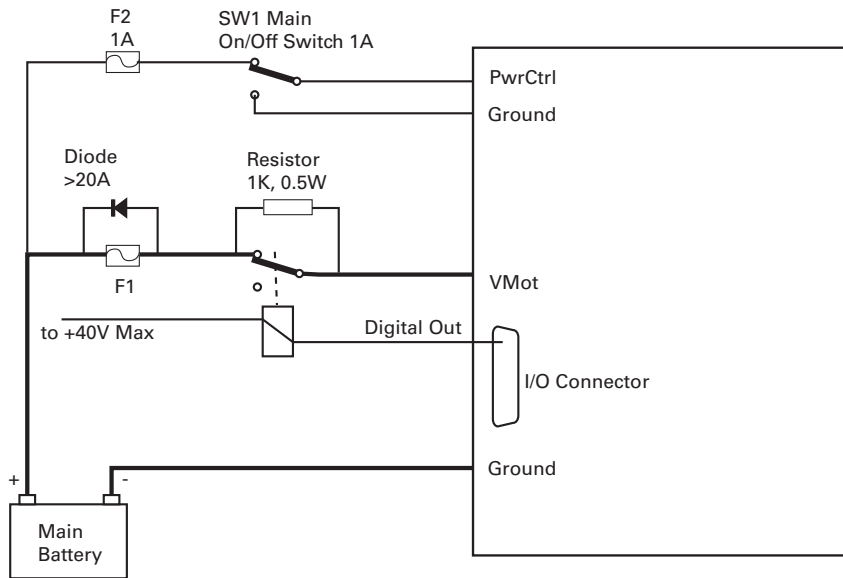

FIGURE 10. Contactor wiring diagram

The contactor coil must be connected to a digital output configured to activate when “No MOSFET Failure.” The controller will automatically deactivate the coil if the output is expected to be off and battery current of 1A or more is measured for more than 0.5s. This circuit will not protect against other sources of failure such as those described in the “Important Safety Disclaimer” on page 3.

Hall Sensors Connection

Connection to the Hall Sensors is done using a special connector on the front side of the controller. The figure below shows the location of the various low-voltage connectors and LEDs on the controller.

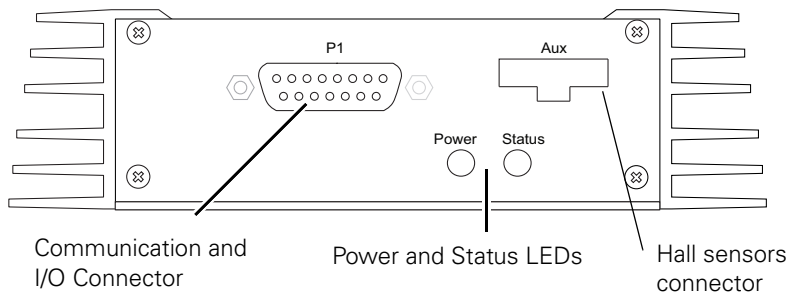

FIGURE 11. Front Controller Layout

The Hall sensor connector is a 10-pin Molex Microfit 3.0, ref. 43025-1000. Pin assignment is in the table below.

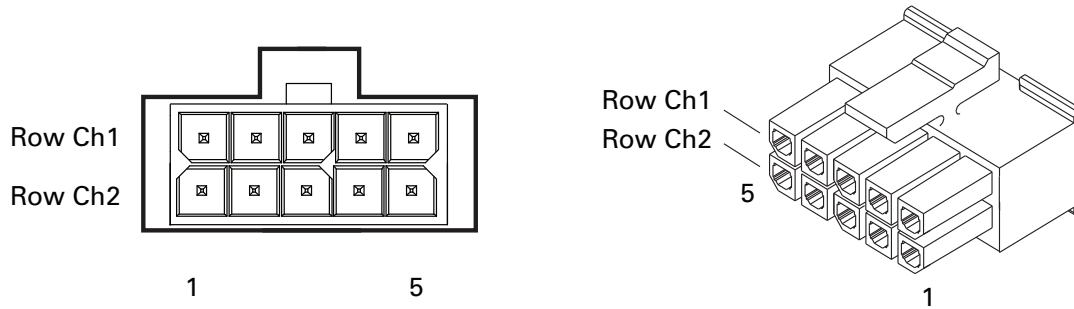

FIGURE 12. Hall Sensors connector

TABLE 4.

| Pin Number | 1 | 2 | 3 | 4 | 5 |
|------------|----|---------|---------|---------|--------|
| Row Ch1 | 5V | Hall1 C | Hall1 B | Hall1 A | Ground |
| Row Ch2 | 5V | Hall2 C | Hall2 B | Hall2 A | Ground |

Hall Sensor vs Motor Output sequencing

The controller requires the Hall sensors inside the motor to be 120 degrees apart. The controller's 3-phase bridge will activate each of the motor winding according to the sequence shown in the figure below.

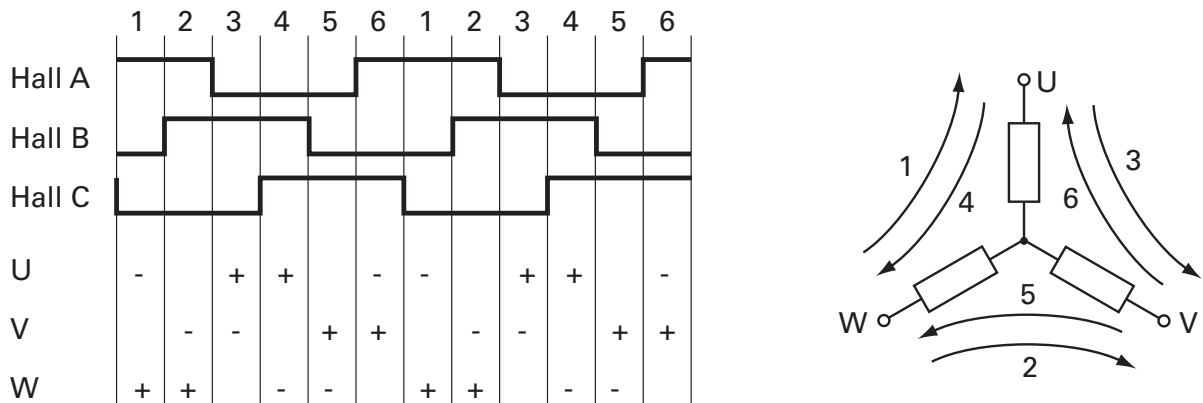

FIGURE 13. Hall Sensors sequence

Commands and I/O Connections

Connection to RC Radio, Microcomputer, Joystick and other low current sensors and actuators is done via the 15-pin connector located in front of the controller. The functions of many pins vary depending on controller model and user configuration. Pin assignment is found in the table below.

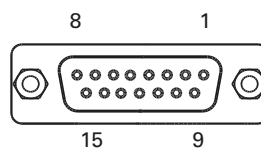

FIGURE 14. Connector pin locations

TABLE 5.

| Connector Pin | Power | Dout | Com | RC | Ana | Dinput | Default Config |
|---------------|-------|-------|-------|-----|------|--------|------------------|
| 1 | | DOUT1 | | | | | Motor Brake |
| 9 | | DOUT2 | | | | | Safety Contactor |
| 2 | | | TxOut | | | | RS232Tx |
| 10 | | | | RC5 | ANA1 | DIN5 | AnaCmd1 (1) |
| 3 | | | RxIn | | | | RS232Rx |
| 11 | | | | RC4 | ANA4 | DIN4 | AnaCmd2 (1) |
| 4 | | | | RC1 | | DIN1 | RCRadio1 |
| 12 | | | | RC3 | ANA3 | DIN3 | Unused |
| 5 | GND | | | | | | |
| 13 | GND | | | | | | |
| 6 | | | SCLI | | | | Reserved |
| 14 | 5VOut | | | | | | |
| 7 | | | SDAI | | | | Reserved |
| 15 | | | | | | DIN6 | Unused |
| 8 | | | | RC2 | ANA2 | DIN2 | RCRadio2 |

Note 1: Analog command is disabled in factory default configuration.

Default I/O Configuration

The controller can be configured so that practically any Digital, Analog and RC pin can be used for any purpose. The controller's factory default configuration provides an assignment that is suitable for most applications. The figure below shows how to wire the controller to two analog potentiometers, an RC radio, and the RS232 port. It also shows how to connect the two outputs to motor brake solenoids. You may omit any connection that is not required in your application. The controller automatically arbitrates the command priorities depending on the presence of a valid command signal in the following order: 1-RS232, 2-RC Pulse, 3-None. If needed, use the Roborun+ PC Utility to change the pin assignments and the command priority order.

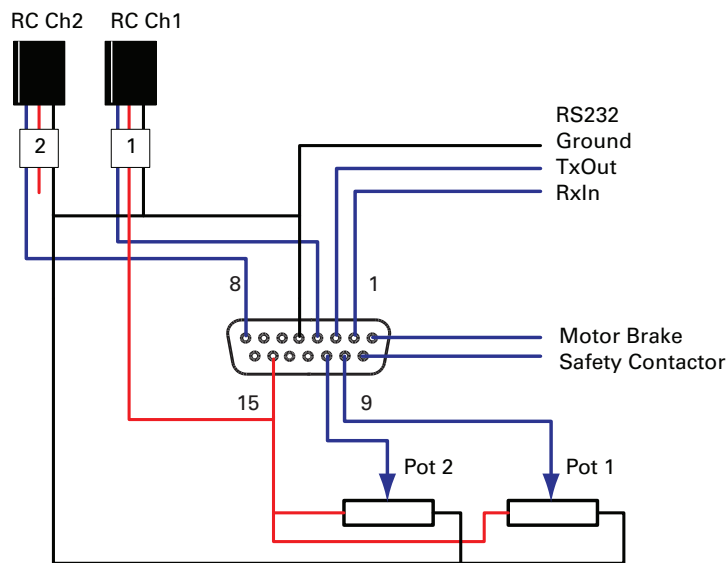

FIGURE 15. Factory default pins assignment

Analog command mode is disabled by default. The drawing shows suggested assignment of Pot 1 to ANA1 and Pot 2 to ANA4. Use the PC utility to enable and assign analog inputs.

Status LED Flashing Patterns

After the controller is powered on, the Power LED will turn on, indicating that the controller is On. The Status LED will be flashing at a 2 seconds interval. The flashing pattern provides operating or exception status information.



FIGURE 16. Normal Operation Flashing Patterns

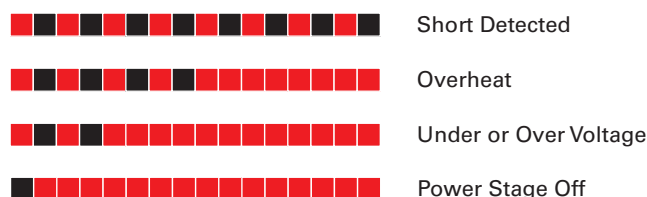

FIGURE 17. Exception or Fault Flashing Patterns

Additional status information may be obtained by monitoring the controller with the PC utility.

Electrical Specifications

Absolute Maximum Values

The values in the table below should never be exceeded, Permanent damage to the controller may result.

TABLE 6.

| Parameter | Measure point | Min | Typ | Max | Units |
|-----------------------------------|--|-----|-----|---------|-------|
| Battery Leads Voltage | Ground to VMot | | | 50 | Volts |
| Reverse Voltage on Battery Leads | Ground to VMot | -1 | | | Volts |
| Power Control Voltage | Ground to Pwr Control wire | | | 65 | Volts |
| Motor Leads Voltage | Ground to U, V, W wires | | | 50 (1) | Volts |
| Digital Output Voltage | Ground to Output pins | | | 30 | Volts |
| Analog and Digital Inputs Voltage | Ground to any signal pin on 15-pin & Hall inputs | | | 15 | Volts |
| RS232 I/O pins Voltage | External voltage applied to Rx/Tx pins | | | 15 | Volts |
| Case Temperature | Case | -40 | | 85 | oC |
| Humidity | Case | | | 100 (2) | % |

Note 1: Maximum regeneration voltage in normal operation. Never inject a DC voltage from a battery or other fixed source

Note 2: Non-condensing

Power Stage Electrical Specifications (at 25oC ambient)

TABLE 7.

| Continuous Max Current per channel | Measure point | Min | Typ | Max | Units |
|---|---|---|------------|------------|---------------|
| Battery Leads Voltage | Ground to VMot | 0 (1) | | 50 | Volts |
| Motor Leads Voltage | Ground to U, V, W wires | 0 (1) | | 50 (2) | Volts |
| Power Control Voltage | Ground to Power Control wire | 0 (1) | | 65 | Volts |
| Minimum Operating Voltage | VMot or Pwr Ctrl wires | 9 (3) | | | Volts |
| Over Voltage protection range | Ground to VMot | 5 | 50 (4) | 50 | Volts |
| Under Voltage protection range | Ground to VMot | 0 | 5 (4) | 50 | Volts |
| Idle Current Consumption | VMot or Pwr Ctrl wires | 50 | 100 (5) | 150 | mA |
| ON Resistance (Excluding wire resistance) | VMot to U, V or W. Ground to U, V or W | | 6 | | mOhm |
| Max Current for 30s | Motor current | | | 75 | Amps |
| Continuous Max Current per channel | Motor current | | | 40(6) | Amps |
| Current Limit range | Motor current | 10 | 50 (7) | 75 | Amps |
| Stall Detection Amps range | Motor current | 10 | 75 (7) | 75 | Amps |
| Stall Detection timeout range | Motor current | 1 | 500 (8) | 65000 | milli-seconds |
| Short Circuit Detection threshold (9) | Between Motor wires or Between Motor wires and Ground | 140 (10) | | 400 (10) | Amps |
| Short Circuit Detection threshold | Between Motor wires and VMot | No Protection. Permanent damage will result | | | |
| Motor Acceleration/Deceleration range | Motor Output | 100 | 500 (11) | 65000 | milli-seconds |

Note 1: Negative voltage will cause a large surge current. Protection fuse needed if battery polarity inversion is possible

Note 2: Maximum regeneration voltage in normal operation. Never inject a DC voltage from a battery or other fixed source

Note 3: Minimum voltage must be present on VMot or Power Control wire

Note 4: Factory default value. Adjustable in 0.1V increments

Note 5: Current consumption is lower when higher voltage is applied to the controller's VMotVMot or PwrCtrl wires

Note 6: Estimate. Limited by case temperature. Current may be higher with better cooling

Note 7: Factory default value. Adjustable in 0.1A increments

Note 8: Factory default value. Time in ms that Stall current must be exceeded for detection

Note 9: Controller will stop until restarted in case of short circuit detection

Note 10: Sensitivity selectable by software

Note 11: Factory default value. Time in ms for power to go from 0 to 100%

Command, I/O and Sensor Signals Specifications

TABLE 8.

| Parameter | Measure point | Min | Typ | Max | Units |
|------------------------|----------------------------|------------|------------|------------|--------------|
| Main 5V Output Voltage | Ground to 5V pins on | 4.6 | 4.75 | 4.9 | Volts |
| 5V Output Current | 5V pins on RJ45 and DSub15 | | | 200 (1) | mA |
| Digital Output Voltage | Ground to Output pins | | | 40 | Volts |

TABLE 8.

| Parameter | Measure point | Min | Typ | Max | Units |
|------------------------------------|---------------------------|-------|------|-------|-------|
| Output On resistance | Output pin to ground | | 0.25 | 0.5 | Ohm |
| Output Short circuit threshold | Output pin | 1.7 | | 3.5 | Amps |
| Digital Output Current | Output pins, sink current | | | 1.5 | Amps |
| Input Impedances (except DIN11-19) | AIN/DIN Input to Ground | | 53 | | kOhm |
| Digital Input 0 Level | Ground to Input pins | -1 | | 1 | Volts |
| Digital Input 1 Level | Ground to Input pins | 3 | | 15 | Volts |
| Analog Input Range | Ground to Input pins | 0 | | 5.1 | Volts |
| Analog Input Precision | Ground to Input pins | | 0.5 | | % |
| Analog Input Resolution | Ground to Input pins | | 1 | | mV |
| Pulse durations | Pulse inputs | 20000 | | 10 | us |
| Pulse repeat rate | Pulse inputs | 50 | | 250 | Hz |
| Pulse Capture Resolution | Pulse inputs | | 1 | | us |
| Frequency Capture | Pulse inputs | 100 | | 10000 | Hz |

Note 1: Sum of all 5VOut outputs

Operating & Timing Specifications

TABLE 9.

| Parameter | Measure Point | Min | Typ | Max | Units |
|-------------------------|--------------------------|-------|------------|-------|--------|
| Command Latency | Command to output change | 1 | 0.5 | 1 | ms |
| PWM Frequency | Motor Output | 10 | 18 | 20 | kHz |
| Closed Loop update rate | Internal | | 1000 | | Hz |
| RS232 baud rate | Rx & Tx pins | | 115200 (1) | | Bits/s |
| RS232 Watchdog timeout | Rx pin | 1 (2) | | 65000 | ms |

Note 1: 115200, 8-bit, no parity, 1 stop bit, no flow control
 Note 2: May be disabled with value 0

Scripting

TABLE 10.

| Parameter | Measure Point | Min | Typ | Max | Units |
|-----------------------------|---------------|--------|---------|------|-----------|
| Scripting Flash Memory | Internal | | 8192 | | Bytes |
| Max Basic Language programs | Internal | 1000 | | 1500 | Lines |
| Integer Variables | Internal | | 1024 | | Words (1) |
| Boolean Variables | Internal | | 1024 | | Symbols |
| Execution Speed | Internal | 50 000 | 100 000 | | Lines/s |

Note 1: 32-bit words

Thermal Specifications

TABLE 11.

| Parameter | Measure Point | Min | Typ | Max | Units |
|--------------------------|-----------------------|-----|-----|--------|-------|
| Case Temperature | Case | -40 | | 85 (1) | oC |
| Thermal Protection range | Case | 80 | | 90 (2) | oC |
| Power Dissipation | Case | | | 70 | Watts |
| Thermal resistance | Power MOSFETs to case | | | 0.6 | oC/W |
| Humidity | Case | | | 100(3) | % |

Note 1: Thermal protection will protect the controller power
 Note 2: Max allowed power out starts lowering at minimum of range, down to 0 at max of range

Mechanical Specifications

TABLE 12.

| Parameter | Measure Point | Min | Typ | Max | Units |
|-----------------------|------------------|-----|------------|-----|-------------|
| Weight | Case | | 1.0 (2.0) | | kg (lbs) |
| Wire Length | Case | | 17 (43) | | inches (mm) |
| Battery Wire Gauge | Wire | | 8 | | AWG |
| Battery Wire Diameter | Outside diameter | | 0.26 (6.6) | | inches (mm) |
| Motor Wire Gauge | Wire | | 8 | | AWG |
| Motor Wire Diameter | Outside diameter | | 0.26 (6.6) | | inches (mm) |

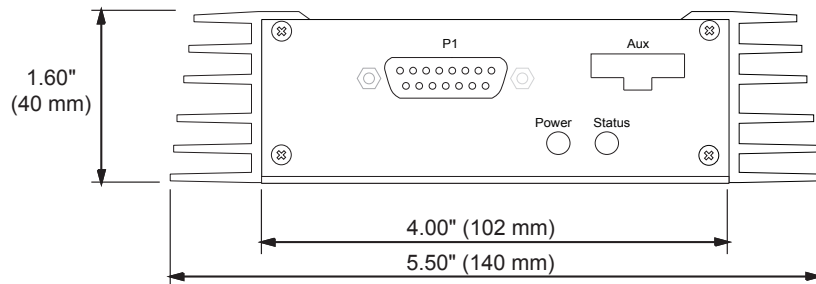

FIGURE 18. VBL2350 front view and dimensions

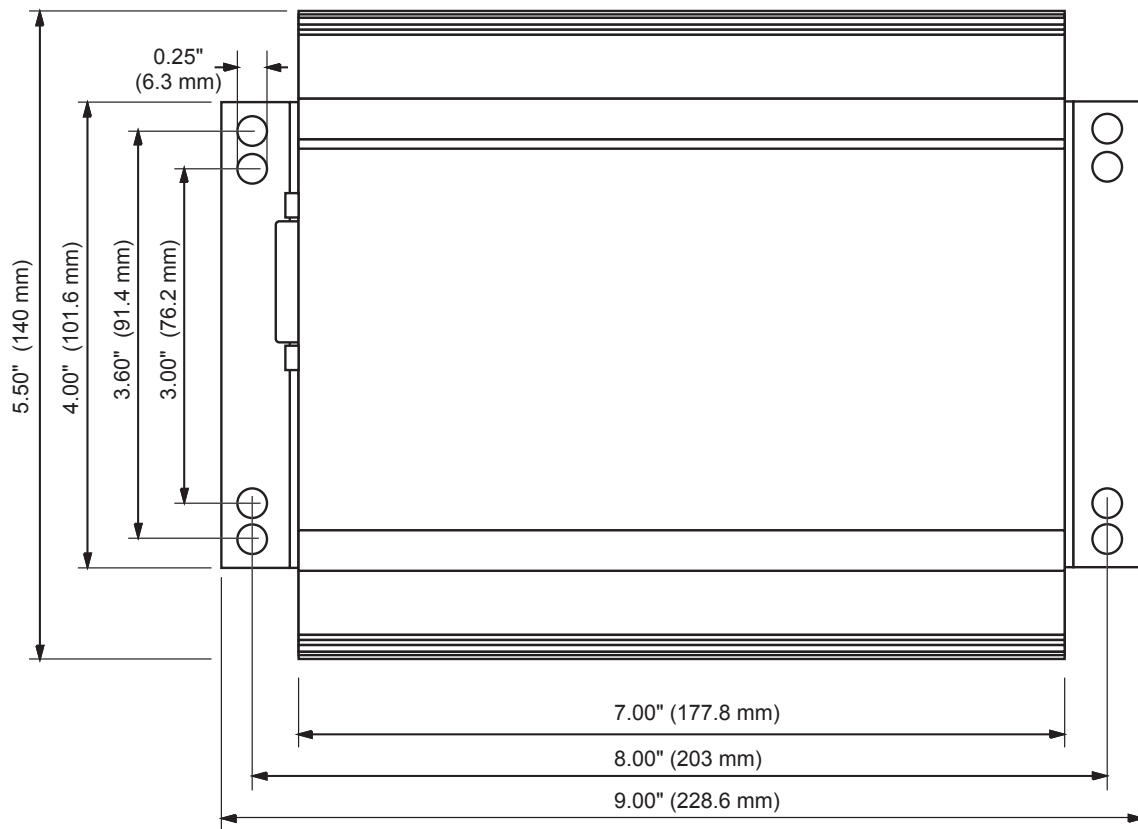

FIGURE 19. VBL2350 top view and dimensions