



FEATURES

- 1.5W continuous output power
- PCB Mounting
- Small size
- Outputs up to 3kV
- Positive or negative polarity
- Output proportional to input
- No minimum load requirements
- Input polarity protected
- Open and short circuit protected
- EU RoHS Compliant to 2002/95/EC
- CE Marked (LVD)

DESCRIPTION

The Series GMA is a unique range of low cost, general purpose high voltage DC to DC converters. All units are configured for direct PCB mounting and are intended to be “designed in” to the customer’s equipment as a component. The Series GMA is suitable for ink jet printing, electrostatic precipitation, Geiger-Muller tubes, photomultiplier tubes, electron beam deflection and focussing, as well as various general purpose applications.

If none of the standard models in this datasheet suit your requirements, please contact our sales team about a custom version.

SPECIFICATION

Output Power:

1.5W max continuous.

Output Voltage:

Units available with maximum output voltages from 100V to 3kV.

Input Voltage:

12V or 24V DC.

Polarity:

Positive or negative to order.

Load Regulation:

Typically less than 10% (for a 0 to 1.5W load change), maximum 20%.

Line Regulation:

Output is proportional to input over a 10% to 100% input range, with a variation of 10% or rated output voltage.

Ripple:

1% peak to peak (0.1% for Screened Case version).

Efficiency:

Better than 50% at 1.5W load.

Oscillator Frequency:

25kHz to 200kHz depending on model.

Protection:

Protected against intermittent flashover.

Operating Temperature:

0 to +40°C.

Options:

Screened Case: Screened case of tin plate construction with its own pin reduces radiated noise and output ripple.

Isolated unit: Isolated units give input to output isolation of up to 100V. This can allow, for example, a sense resistor to be added for load current measurements. A capacitor may be added between the input 0V and output 0V to reduce common mode ripple.

Operation:

The unregulated output is proportional to the input voltage. Alternatively external feedback control loops can be added to provide regulated outputs. The converters are vacuum encapsulated in an ABS case to ensure maximum reliability and safety. Standard GMA models are three pin devices which provide a common 0V for input and output. All models are available with a range of input and output voltages, with either positive or negative output.

Series GMA

MINIATURE HIGH VOLTAGE DC-DC CONVERTERS



Safety:

This DC-DC converter meets the requirements of the Low Voltage Directive (LVD) 73/23/EEC, by complying with BS EN60950 when it is installed as a component part of other equipment and is CE marked accordingly.

RoHS:

The Series GMA meets the requirements of EU Directive 2002/95/EC on the Restriction of use of certain Hazardous Substances in Electrical and Electronic Equipment (RoHS).

Mechanical specification:

Dimensions: See outline drawing
Weight: 60g (2 oz) approx.

Outputs and ordering information:

Model no	Input Voltage	Output Voltage
GMA12-100*E	12V	100V
GMA24-100*E	24V	100V
GMA12-200*E	12V	200V
GMA24-200*E	24V	200V
GMA12-300*E	12V	300V
GMA24-300*E	24V	300V
GMA12-500*E	12V	500V
GMA24-500*E	24V	500V
GMA12-1K*E	12V	1kV
GMA24-1K*E	24V	1kV
GMA12-1K5*E	12V	1.5kV
GMA24-1K5*E	24V	1.5kV
GMA12-2K*E	12V	2kV
GMA24-2K*E	24V	2kV
GMA12-3K*E	12V	3kV
GMA24-3K*E	24V	3kV

*Please add the required suffix to the model number:

P or N Positive or negative polarity.
S Screened version
I Isolated unit

eg GMA12-300PSE for a positive, screened 300V unit.

Series GMA

MINIATURE HIGH VOLTAGE DC-DC CONVERTERS



UNSCREENED VERSION

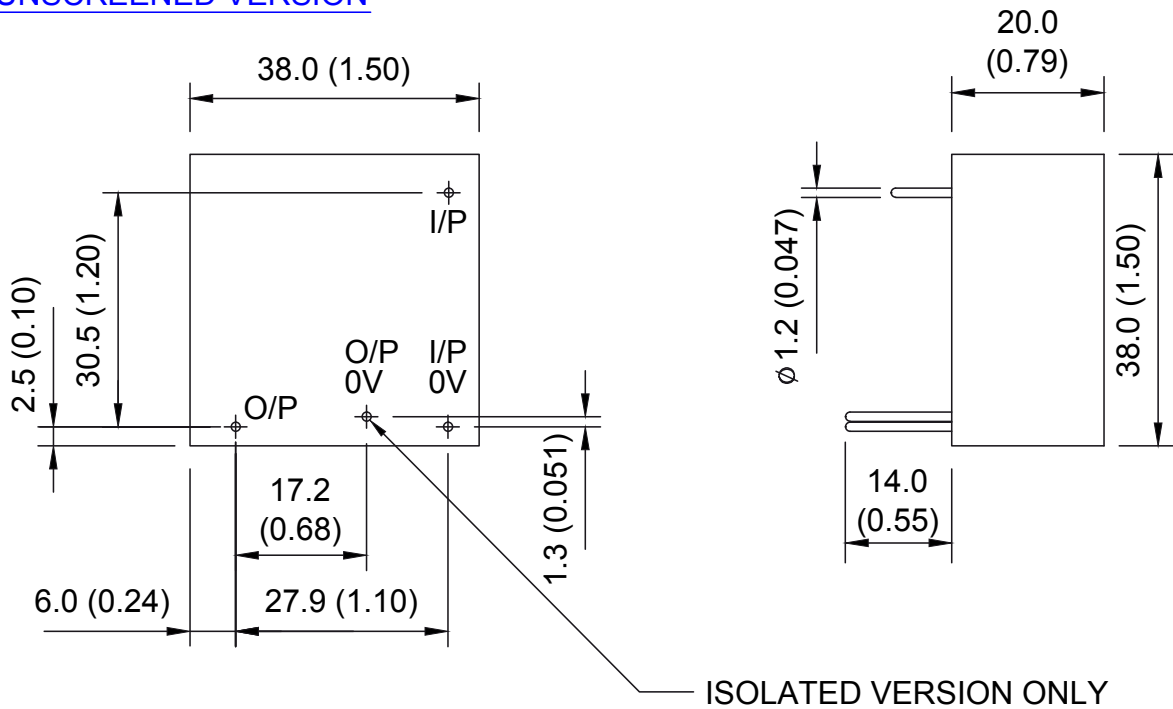

SCREENED VERSION

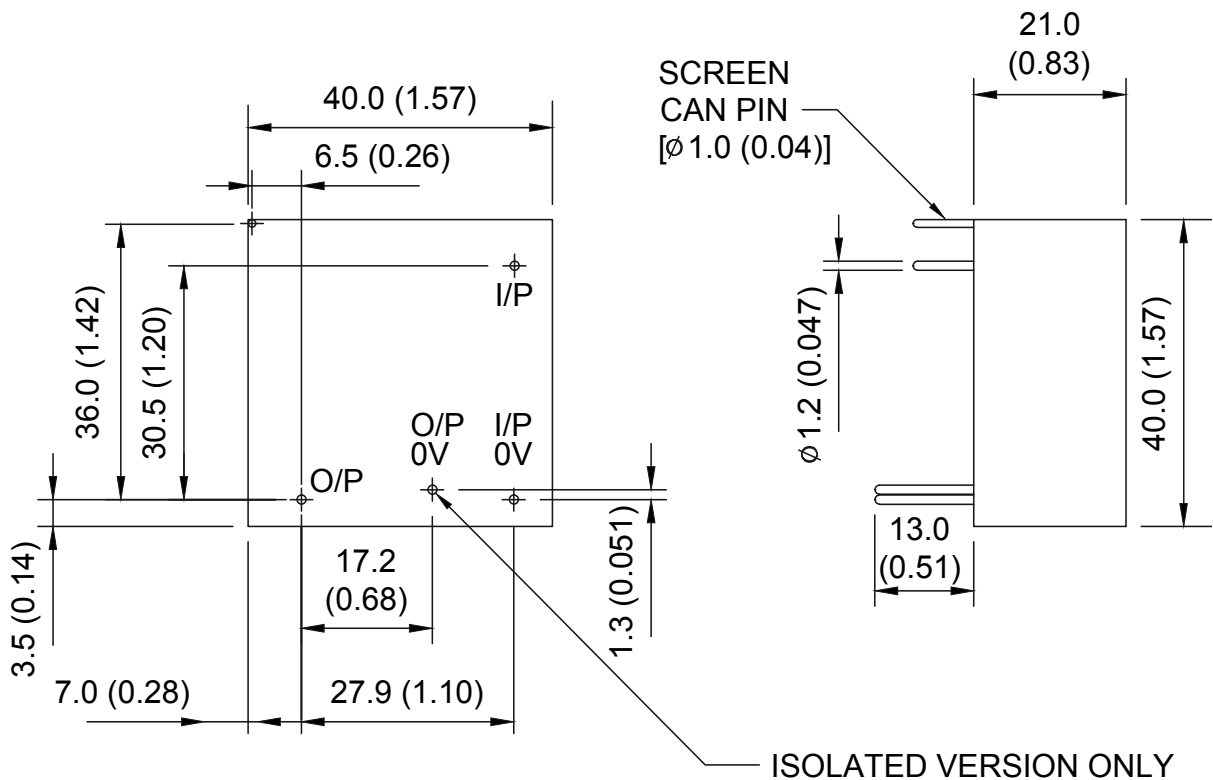

Drawing dimensions are in mm (inches)
Design developments may result in specification changes

HiTek



Power

*The Power Supply
Pioneer*

UK

HiTek Power Ltd
Hawthorn Road, Littlehampton
West Sussex BN17 7LT
UK
Tel: **+44 (0) 1903 712400**
Fax: **+44 (0) 1903 712500**
e-mail: sales.uk@hitekpower.com

USA

HiTek Power Inc
124 Jewett Street, Unit #2
Georgetown, MA 01833-1868
USA
Tel: **+1 (978) 352-9100**
Fax: **+1 (978) 352-9133**
e-mail: sales.us@hitekpower.com

GERMANY

HiTek Power GmbH
Joh.-Friedr.-Boettger-Str. 21
D-63322 Roedermark
Germany
Tel: **+49 (0) 6074 69285 0**
Fax: **+49 (0) 6074 69285 10**
e-mail: sales.de@hitekpower.com

JAPAN

HiTek Power Japan
1-5-13 Kyutaroumachi
Chou-ku, Osaka 541-0056
Japan
Tel: **+81 (6) 6271 8180**
Fax: **+81 (6) 6271 8190**
e-mail: info@hitekpowerjapan.co.jp