



FEATURES

- 20kW of output power
- Output voltages from 60kV to over 200kV
- Positive or Negative polarity to order
- Robust IGBT converter design
- Exceptional reliability
- High Stability
- Excellent inherent ruggedness
- Arc Count and Extinguish (ACE) option
- C € Marked

DESCRIPTION

The Series OL20K is a range of high reliability products designed to meet the rigorous requirements of ion and electron beam systems. These high performance switch mode systems are based on a power converter using zero-volt switching. A full bridge of the latest generation of Insulated Gate Bipolar Transistors (IGBTs) in a fully regulated closed-loop system capable of continuously supplying up to 20kW of output power whilst maintaining flexible control down to a few hundred Watts. These highly reliable rugged systems comprise two units, a rack mounting power converter through which remote controls are facilitated, and a separate HV unit employing a modular disc construction. Numerous features are incorporated to ensure system integrity is maintained during adverse operating conditions. Such features include continuous primary current monitoring with fast pulse truncation and soft recovery, extensive thermal monitoring and automatic shutdown on key components, passive output current limiting for instantaneous surge control and independent output overvoltage sensing. Optionally HiTek Power's Arc Count and Extinguish (ACE) system can be installed for active arc management.

SPECIFICATION

Output Power:

20kW maximum at full rated output voltage and current.

Output Voltage:

Units available with maximum output voltages from 60kV to 200kV.

Output Current:

Up to 250mA for 60kV and 80mA for 200kV.

Input Voltage:

208VAC $\pm 10\%$ (187VAC to 229VAC) 47-63Hz 3 phase via three M8 studs, and earth, via M10 stud at 87A rms per phase.

OR

400VAC $\pm 10\%$ (360VAC to 440VAC) 47-63Hz 3 phase via three M6 studs, and earth, via M8 stud 45A rms per phase.

Polarity:

Positive or negative to order.

Minimum Voltage:

5% of rated output voltage. The unit may be turned down below this but the specifications are not guaranteed below this level.

Line Regulation:

Less than 0.1% change in output voltage for a 10% change in mains voltage.

Load Regulation:

Less than 0.1% of rated output voltage for a full load change.

Ripple:

Less than 0.1% peak to peak of rated output voltage.

Transient Response:

The output will recover to within $\pm 1\%$ of set value in less than 100ms from the removal of a short circuit.

Temperature Coefficient:

200ppm/ $^{\circ}$ C (0.02%/ $^{\circ}$ C).

Series OL20K

20kW HIGH VOLTAGE POWER SUPPLY



Drift:

Less than 0.5%/8 hours after 1 hour warm up.

Front Panel Controls and Indicators:

- Circuit Breaker HV On indicator
- HV Off indicator
- Trip indicator

Operating Temperature:

0°C to +40°C (32°F to 140°F) ambient and air intake.

Storage Temperature:

-20°C to +85°C (-4°F to 185°F).

Humidity:

80% maximum relative humidity up to 31°C, reducing linearly to 50% at 40°C. Non-condensing (ref BS EN61010-1).

Vibration:

In accordance with BS EN60068-2-6: 1995

Transport, when contained in the original packaging.

Frequency range: 10Hz to 500Hz

Acceleration: 20m/s² crossover at 58Hz (table C.2)

Displacement: 0.15mm maximum

Test conditions as defined in table A.1.

Altitude:

Sea level to 2000 metres (6500 feet).

Installation Category:

II (BS EN61010-1)

Pollution Degree:

2 (BS EN61010-1)

Usage:

Indoor use only.

Control:

The power supply is operated by remote control via the 25-way D-type connector situated on the rear panel of the converter. Full control and monitoring functions are available by this method. Application of 0 to 10V to the voltage and current control lines programmes the unit for 0 to 100% of rated output. Similarly 0 to 10V signals provide monitors of the output voltage and current levels. HV ON/OFF is obtained by shorting two terminals and status lines are provided by open collector outputs.

Protection:

The units are fully protected against over voltage, over current, over temperature, load arcing and output short circuits. The ACE system can be installed to give added arc management functionality.

Safety:

The OL20K high voltage power supplies meet the requirements of the Low Voltage Directive, LVD, 73/23/EEC by complying with BS EN61010-1:2001 when installed as a component part of other equipment. They are CE marked accordingly.

RoHS:

The OL20K is currently built to non-RoHS standard. This unit can, however, be configured to meet the requirements of RoHS where significant customer demand requires it, although please note that this will have an impact on delivery timescales.

Mechanical Specification:

Dimensions: See outline drawings.

Weight: Converter 64kg (141 lb).

Stack - see table

Connections: All connections are mounted on the rear panel.

HV Output: M5 bush mounted on HV unit.

Front Panel: Stoving enamel trimate semi-gloss S60/6 colour cream R87177 as standard.

Outputs and Ordering Information:

| Model no (208VAC input) | Model no (400VAC input) | Output Voltage | Output Current | HV Stack Weight |
|-------------------------|-------------------------|----------------|----------------|-----------------|
| OL20K/603* | OL20KE/603* | 60kV | 250mA | 78kg |
| OL20K/803* | OL20KE/803* | 80kV | 240mA | 86.5kg |
| OL20K/104* | OL20KE/104* | 100kV | 200mA | 95kg |
| OL20K/124* | OL20KE/124* | 120kV | 160mA | 103.5kg |
| OL20K/144* | OL20KE/144* | 140kV | 130mA | 112kg |
| OL20K/164* | OL20KE/164* | 160kV | 110mA | 120.5kg |
| OL20K/184* | OL20KE/184* | 180kV | 90mA | 129kg |
| OL20K/204* | OL20KE/204* | 200kV | 80mA | 137.5kg |

* Please add the required suffix to the part number:

P Positive polarity

N Negative polarity

R Arc Count and Extinguish (ACE) system

eg OL20KE/803PR for an 80kV positive polarity unit with ACE system and 400VAC input voltage.

Interface Connections:

25-way D-type connector:

| | | | |
|---------------------------|----|----|---------------------------|
| V STATUS INDICATOR | 1 | 14 | HV OUTPUT CURRENT MONITOR |
| I STATUS INDICATOR | 2 | 15 | HV OFF INDICATOR |
| HV OUTPUT VOLTAGE MONITOR | 3 | 16 | REMOTE INDICATOR |
| TRIP INDICATOR | 4 | 17 | RESERVED |
| LOCAL INDICATOR | 5 | 18 | +10V REFERENCE VOLTAGE |
| HV ON INDICATION | 6 | 19 | RESERVED |
| PROGRAM VOLTAGE MONITOR | 7 | 20 | RESERVED |
| HV ON Lo | 8 | 21 | ENABLE Lo |
| HV ON Hi | 9 | 22 | ENABLE Hi |
| PROGRAM VOLTAGE Hi | 10 | 23 | CURRENT PROGRAM 0V |
| PROGRAM VOLTAGE Lo | 11 | 24 | CURRENT PROGRAM |
| 0V | 12 | 25 | RESERVED |
| 0V | 13 | | |

Series OL20K
20kW HIGH VOLTAGE POWER SUPPLY

CE These component power supplies meet the requirements of EC Directive 73/23/EEC (LVD)

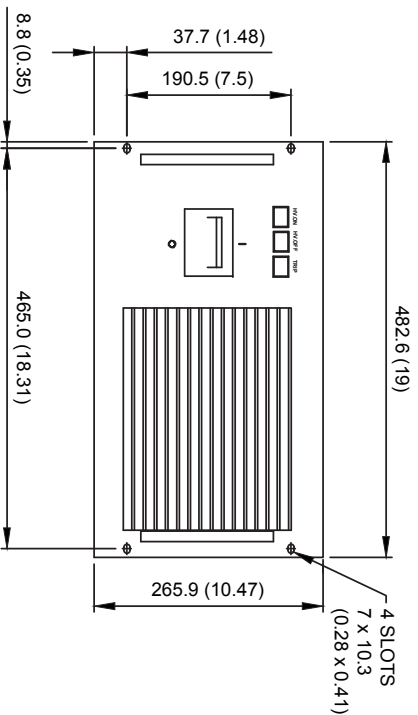
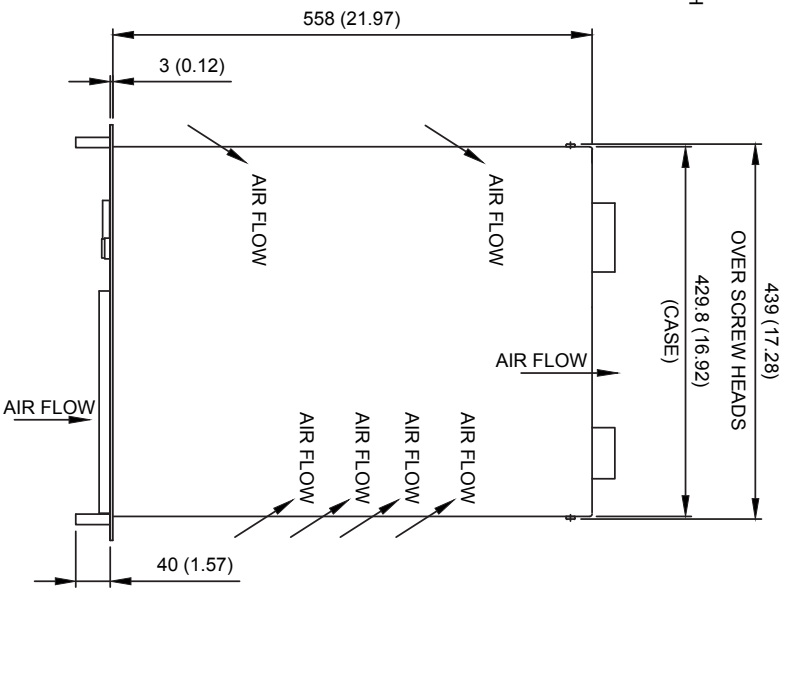
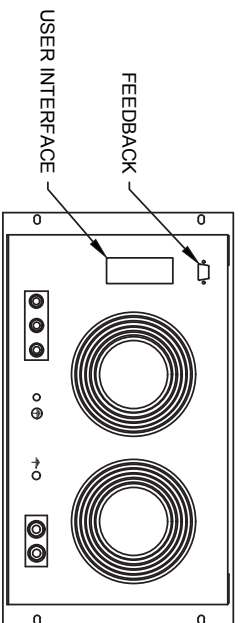
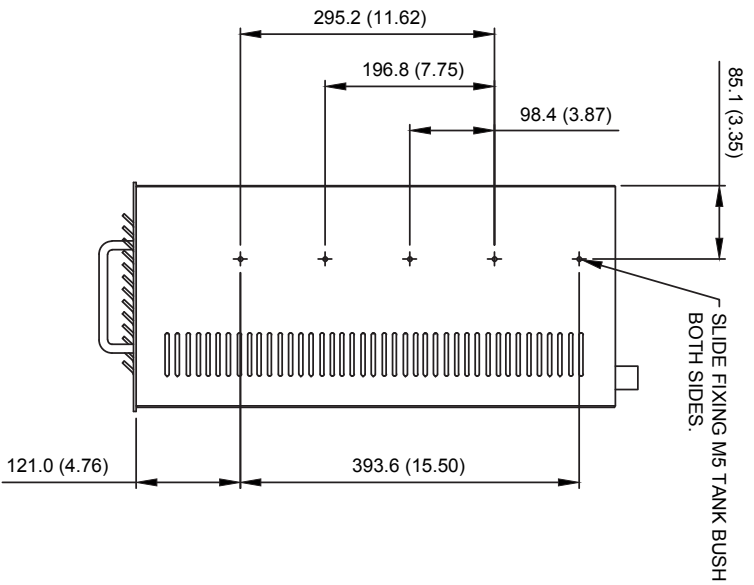

Drawing dimensions are in mm (inches)
Design developments may result in specification changes

Series OL20K

20kW HIGH VOLTAGE POWER SUPPLY



| OUTPUT kV | DIM 'A' NOMINAL |
|-----------|---|
| 60 | 313.0 (MAX), 303.0 (MIN) (12.32 (MAX), 11.93 (MIN)) |
| 80 | 365.0 (MAX), 353.0 (MIN) (14.37 (MAX), 13.90 (MIN)) |
| 100 | 417.0 (MAX), 403.0 (MIN) (16.42 (MAX), 15.87 (MIN)) |
| 120 | 470.0 (MAX), 453.0 (MIN) (18.50 (MAX), 17.83 (MIN)) |
| 140 | 522.0 (MAX), 503.0 (MIN) (20.56 (MAX), 19.80 (MIN)) |
| 160 | 574.0 (MAX), 553.0 (MIN) (22.60 (MAX), 21.77 (MIN)) |
| 180 | 626.0 (MAX), 603.0 (MIN) (24.65 (MAX), 23.74 (MIN)) |
| 200 | 678.0 (MAX), 653.0 (MIN) (26.69 (MAX), 25.71 (MIN)) |

AIR FLOW ←

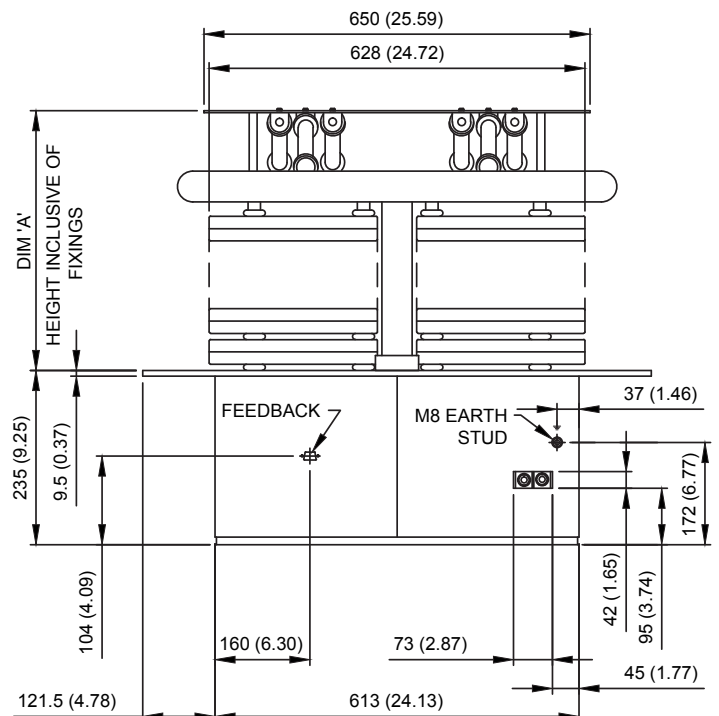
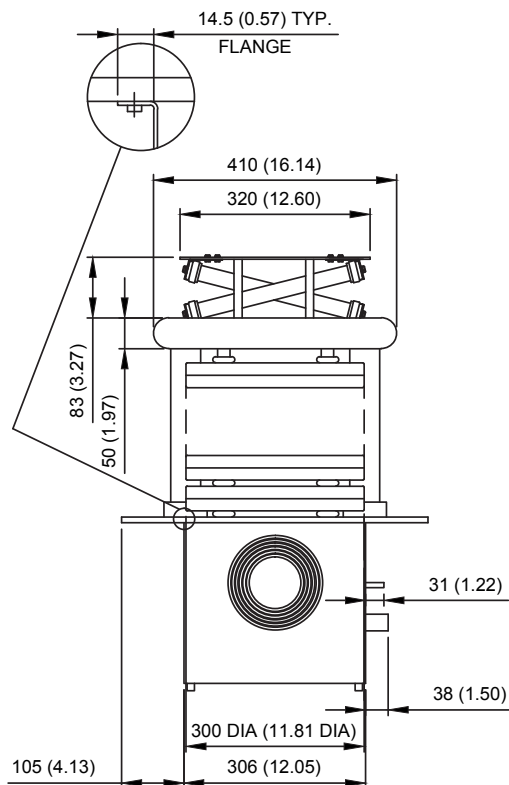
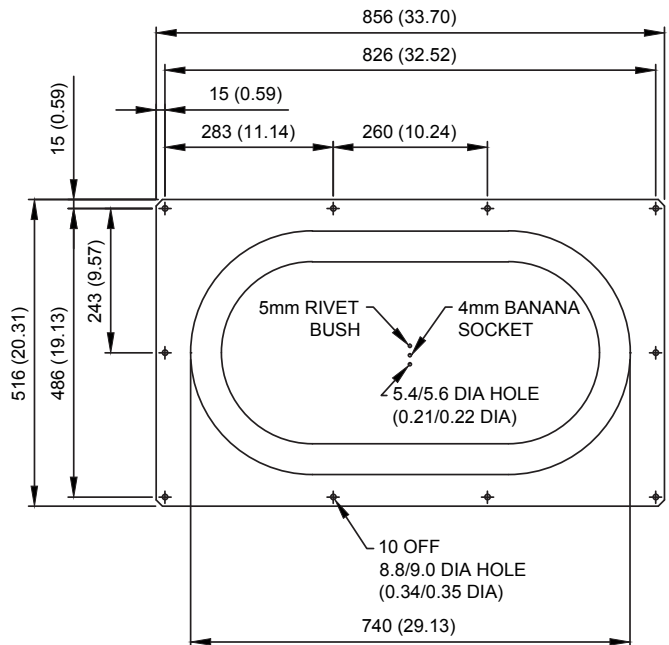

Drawing dimensions are in mm (inches)
Design developments may result in specification changes

HiTek



Power

*The Power Supply
Pioneer*

UK

HiTek Power Ltd
Hawthorn Road, Littlehampton
West Sussex BN17 7LT
UK

Tel: **+44 (0) 1903 712400**

Fax: **+44 (0) 1903 712500**

e-mail: sales.uk@hitekpower.com

USA

HiTek Power Inc
124 Jewett Street, Unit #2
Georgetown, MA 01833-1868
USA

Tel: **+1 (978) 352-9100**

Fax: **+1 (978) 352-9133**

e-mail: sales.us@hitekpower.com

GERMANY

HiTek Power GmbH
Joh.-Friedr.-Boettger-Str. 21
D-63322 Roedermark
Germany

Tel: **+49 (0) 6074 69285 0**

Fax: **+49 (0) 6074 69285 10**

e-mail: sales.de@hitekpower.com

JAPAN

HiTek Power Japan
1-5-13 Kyutaroumachi
Chou-ku, Osaka 541-0056
Japan

Tel: **+81 (6) 6271 8180**

Fax: **+81 (6) 6271 8190**

e-mail: info@hitekpowerjapan.co.jp