

Series OL6000

6kW HIGH VOLTAGE POWER SUPPLY



FEATURES

- 6kW of output power
- Output voltages from 60kV to over 200kV
- Positive or Negative polarity to order
- Robust IGBT converter design
- Low stored energy
- Exceptional reliability
- High stability
- Low ripple
- Arc and short circuit protected
- $\text{C} \text{ } \text{E}$ Marked for EU LV Directive 73/23/EEC

DESCRIPTION

The Series OL6000 is a range of high reliability, high voltage power supply systems designed to meet the rigorous requirements of ion and electron beam systems within a compact assembly. The design utilises IGBT technology operating at 20kHz to provide superior performance, coupled with an unrivalled resistance to damage from surges and arcs. The power converter uses a unique non-dissipative snubber which keeps the main power IGBTs cool, enhancing their long term reliability. The high voltage modules within the system are based on HiTek Power's proprietary disc technology proven over many years and thousands of modules to achieve the ultimate performance and reliability in high voltage generators. Each system consists of two units: the converter, housed in a 4U (7") 19" rack mounting unit and the HV unit, which is a separate high voltage multiplier assembly.

SPECIFICATION

Output Power:

6kW maximum at full rated output voltage and current.

Output Voltage:

Units available with maximum output voltages from 60kV to 200kV.

Output Current:

Up to 100mA for 60kV and 30mA for 200kV.

Input Voltage:

187VAC to 229VAC, 47-63Hz 3 phase and earth.

Polarity:

Positive or negative to order.

Line Regulation:

0.02% of rated output voltage for 10% change in mains voltage.

Load Regulation:

0.05% of rated output voltage for 1% to 100% change in load current where 100% is the rated current at rated output voltage.

Ripple:

Standard unit: 0.14% peak to peak of rated output voltage.
(0.1% at 5kW)

Filtered unit (F): 0.07% peak to peak of rated output voltage.
(0.05% at 5kW)

Transient Response:

The output will recover to within 1% of set value in less than 100ms from the removal of a short circuit.

Efficiency:

Greater than 80% at full load and rated output voltage.

Temperature Coefficient:

200ppm/°C max. Typically better than 100ppm/°C.

Operating Temperature:

0°C to +40°C.

Storage Temperature:

-20°C to +50°C.

Humidity:

85% maximum relative humidity. Non-condensing.

Series OL6000

6kW HIGH VOLTAGE POWER SUPPLY

Altitude:

Sea level to 2000 metres (6500 feet).

Local Controls and Indicators:

AC supply 3 pole circuit breaker, AC ON indicator, HV ON/OFF switch, HV ON indicator, Local/Remote switch, Trip indicator, Voltage Control and Current Control indicators, 10-turn voltage control potentiometer, analogue output voltage meter, analogue output current meter.

The power supply is operated by remote control via the 25-way D-type connector situated on the rear panel of the converter. Full control and monitoring functions are available by this method.

Protection:

The units are fully protected against over-voltage, over-current, over-temperature, load arcing and output short circuit.

Optional Arc Count and Extinguish (ACE):

Each time the ACE system detects an arc it blanks the supply off for a brief period to extinguish the arc. The unit is then allowed to recover. If more arcs occur they are counted to determine the arc rate; if this exceeds a safe level the power supply is shut down. The parameters are factory set.

Safety:

All materials used meet or exceed the requirements of UL94 V-1 for flammability. Meets the requirements of the Low Voltage Directive, 73/23/EEC, by complying with BSEN60950 when installed as a component part of compliant equipment. Units are CE marked accordingly.

RoHS:

The OL6000 is currently built to non-RoHS standard. This unit can, however, be configured to meet the requirements of RoHS where significant customer demand requires it, although this will have an impact on delivery timescales.

Mechanical Specification:

Dimensions: See outline drawing
 Weight: Converter 36kg
 See table below for HV Unit.
 Mains: Via high current connector.
 HV output: M5 bush provided on HV unit.
 Connections: All connectors are mounted on the rear panel.

Interface Connections:

25-way D-type connector:

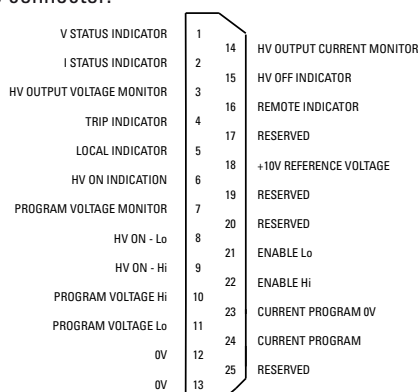

Outputs and Ordering Information:

Model no	Output Voltage	Output Current	HV Unit Weight	
			Standard	Filtered
OL6000/603*	60kV	100mA	31kg	32kg
OL6000/803*	80kV	75mA	35kg	37kg
OL6000/104*	100kV	60mA	40kg	42kg
OL6000/124*	120kV	50mA	44kg	-
OL6000/144*	140kV	42mA	49kg	-
OL6000/164*	160kV	37mA	53kg	-
OL6000/184*	180kV	33mA	58kg	-
OL6000/204*	200kV	30mA	62kg	-

* Please add the required suffix to the part number:

- P Positive polarity
- N Negative polarity
- A Analogue meter
- D Digital meters
- B Blank front panel (remote control only)
- S Surge limit resistor (optional)
- F Filtered unit
- R Arc Count and Extinguish (ACE) system

eg OL6000/204PAR for a 200kV positive polarity unit with analogue meter and ACE system.

Higher voltages than those in the table are available to special order, but at a reduced output power. Please contact our sales team for more information.

If required, this unit can be configured to meet the requirements of RoHS providing a significant quantity is ordered - please contact our sales team.

CE These component power supplies meet the requirements of EC Directive 73/23/EEC (LVD)

Series OL6000

6kW HIGH VOLTAGE POWER SUPPLY

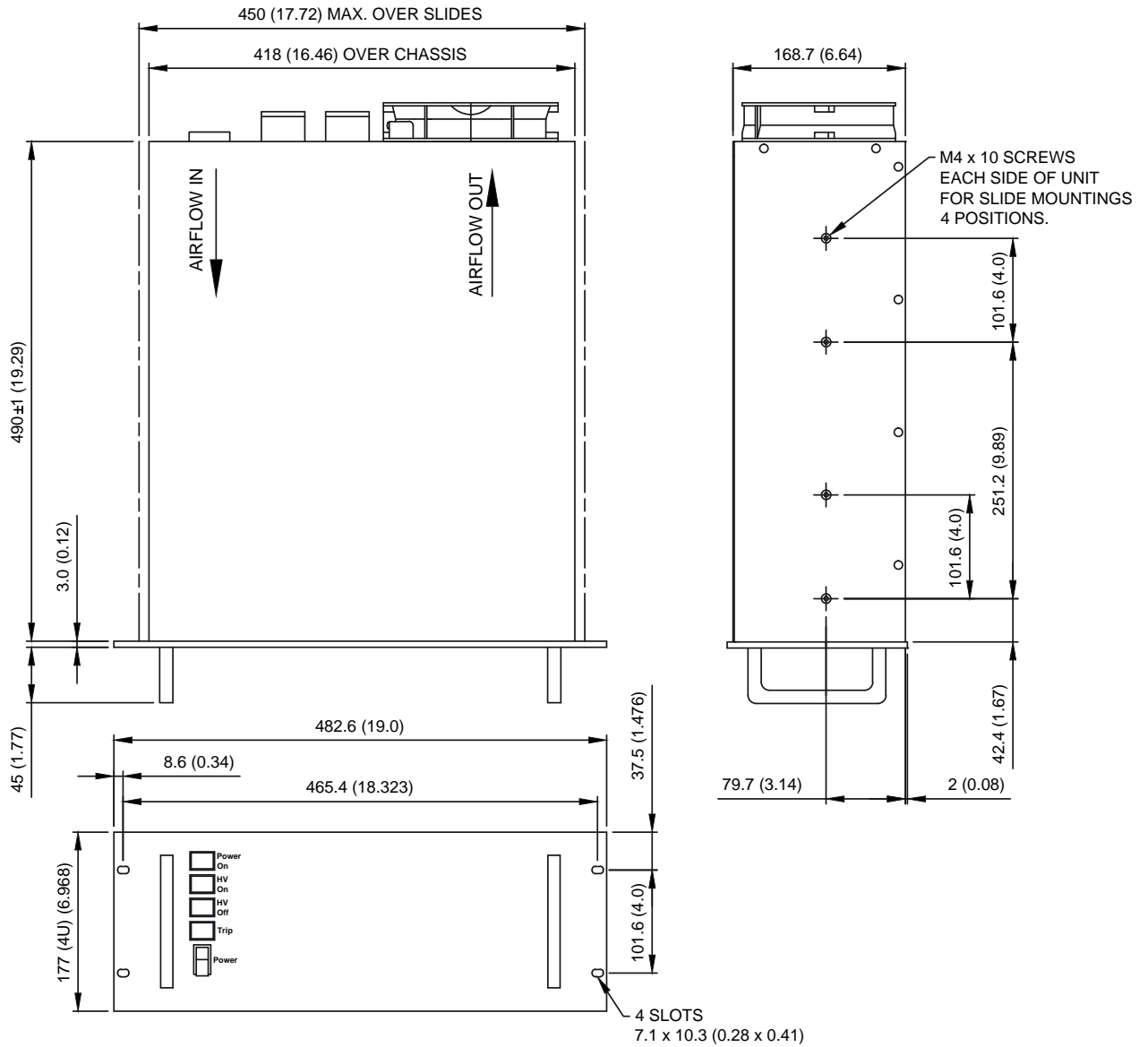
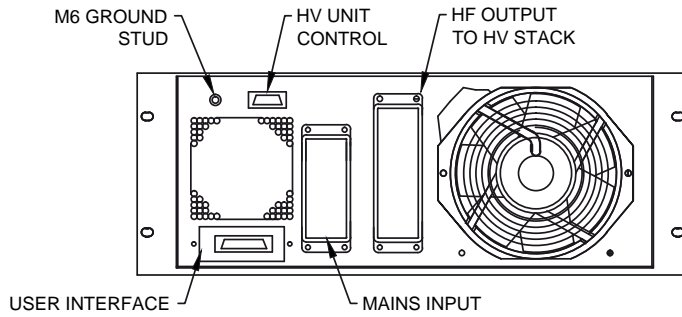

Drawing dimensions are in mm (inches)
Design developments may result in specification changes

Series OL6000

6kW HIGH VOLTAGE POWER SUPPLY

Standard Unit:

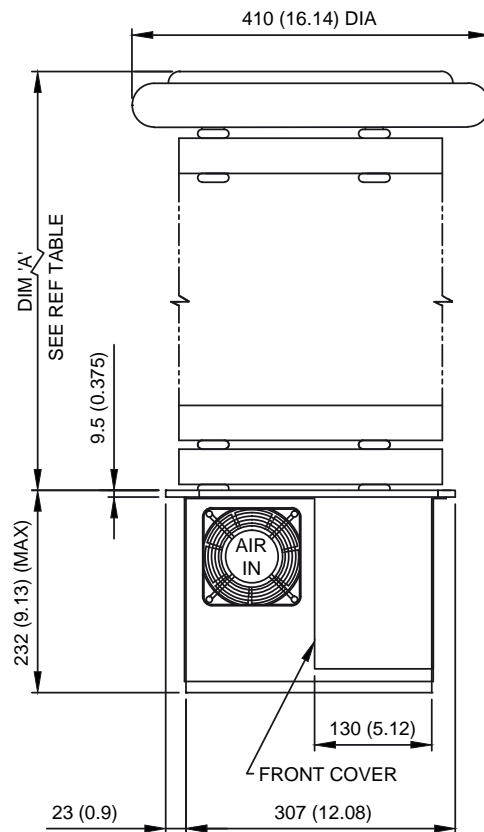
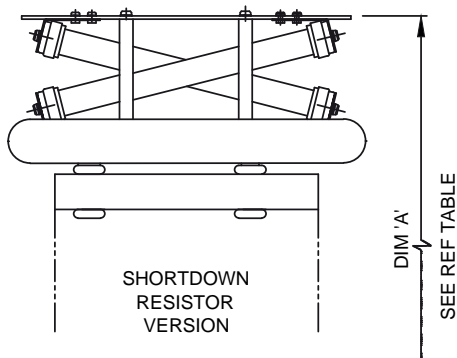
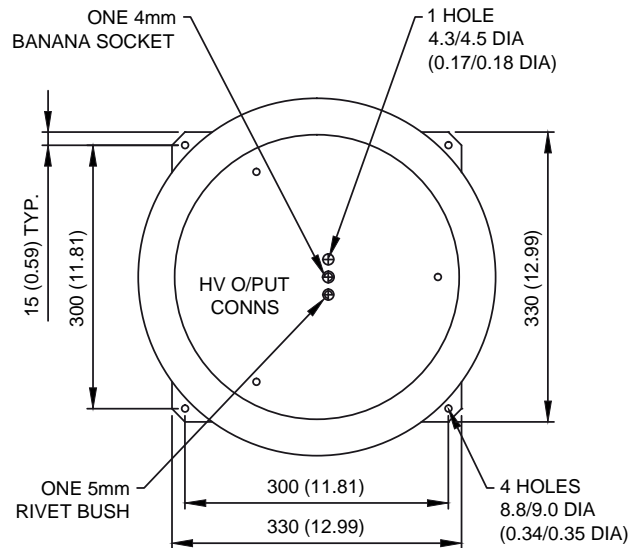
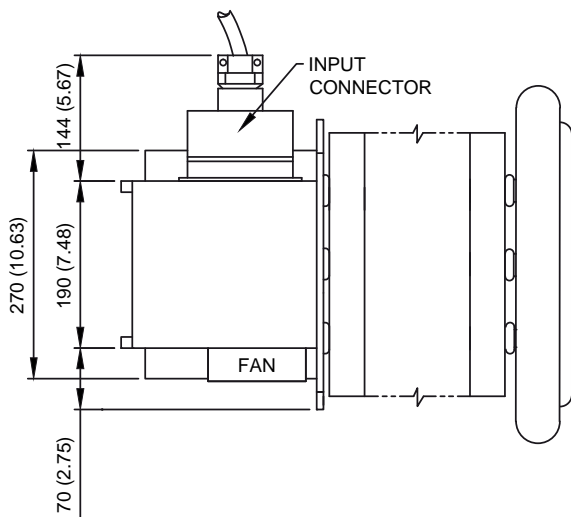

OUTPUT kV	DIM 'A' NOMINAL	
	NO SHORTDOWN	SHORTDOWN
60	223 (8.78)	303 (11.93)
80	273 (10.75)	353 (13.90)
100	323 (12.72)	403 (15.87)
120	373 (14.69)	453 (17.84)
140	423 (16.65)	503 (19.80)
160	473 (18.62)	553 (21.77)
180	523 (20.60)	603 (23.74)
200	573 (22.56)	653 (25.71)

Drawing dimensions are in mm (inches)
Design developments may result in specification changes

Series OL6000

6kW HIGH VOLTAGE POWER SUPPLY

Filtered Unit - Option F:

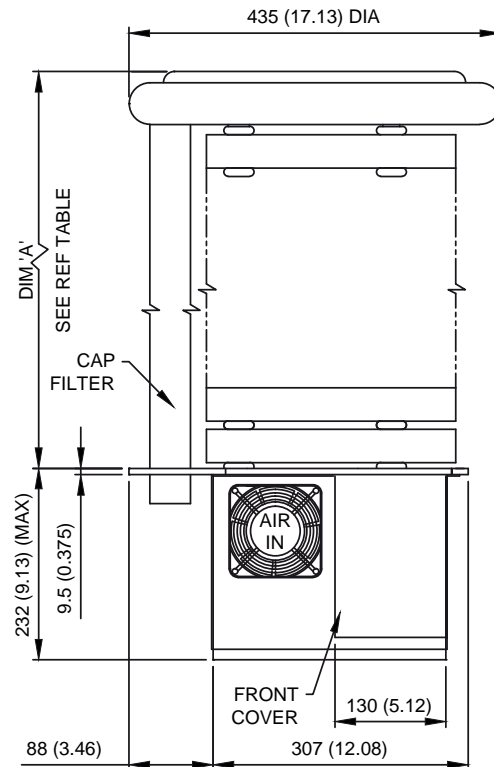
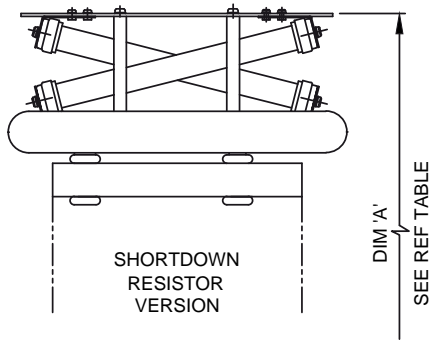
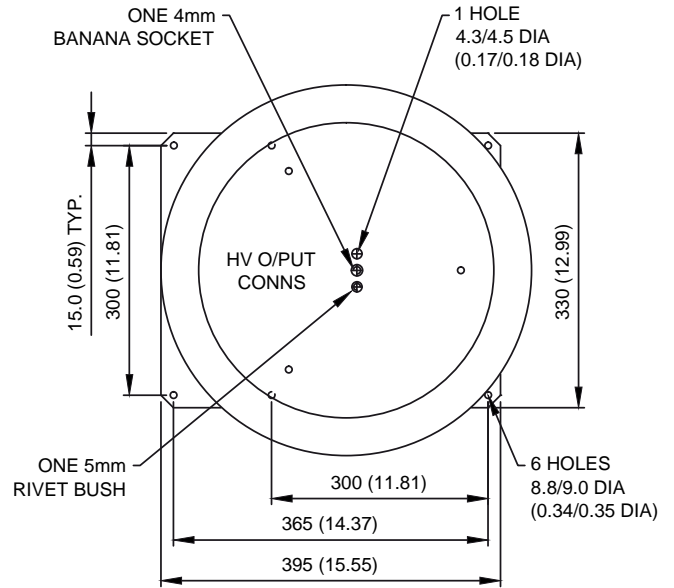
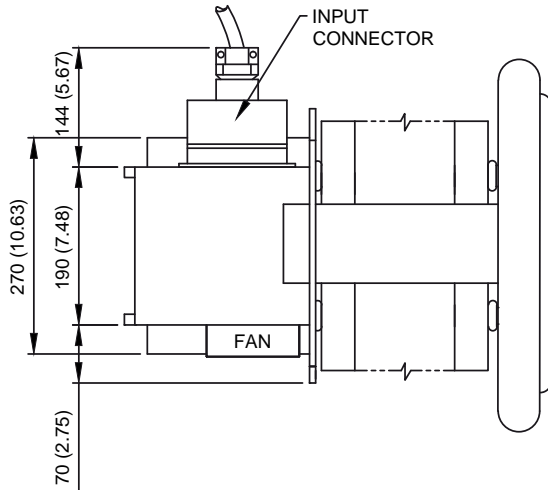

OUTPUT kV	DIM 'A' NOMINAL	
	NO SHUTDOWN	SHUTDOWN
60	223 (8.78)	303 (11.93)
80	273 (10.75)	353 (13.90)
100	323 (12.72)	403 (15.87)
120	373 (14.69)	453 (17.84)
140	423 (16.65)	503 (19.80)
160	473 (18.62)	553 (21.77)
180	523 (20.60)	603 (23.74)
200	573 (22.56)	653 (25.71)

Drawing dimensions are in mm (inches)
Design developments may result in specification changes

UK

HiTek Power Ltd
Hawthorn Road, Littlehampton
West Sussex BN17 7LT
UK
Tel: **+44 (0) 1903 712400**
Fax: **+44 (0) 1903 712500**
e-mail: sales.uk@hitekpower.com

GERMANY

HiTek Power GmbH
Joh.-Friedr.-Boettger-Str. 21
D-63322 Roedermark
Germany
Tel: **+49 (0) 6074 69285 0**
Fax: **+49 (0) 6074 69285 10**
e-mail: sales.de@hitekpower.com

USA

HiTek Power Inc
124 Jewett Street, Unit #2
Georgetown, MA 01833-1868
USA
Tel: **+1 (978) 352-9100**
Fax: **+1 (978) 352-9133**
e-mail: sales.us@hitekpower.com

JAPAN

HiTek Power Japan
1-5-13 Kyutaroumachi
Chou-ku, Osaka 541-0056
Japan
Tel: **+81 (6) 6271 8180**
Fax: **+81 (6) 6271 8190**
e-mail: info@hitekpowerjapan.co.jp