

## Inductive linear sensors

## IWRM 30Z8704/S14C

## dimension drawing



## general data

mounting type	quasi shielded
special type	2 adjust. switching points
measuring distance Sd	0 ... 16 mm
resolution	< 0,01 mm (stat.) < 0,01 mm (dynam.)
repeat accuracy	< 0,015 mm
adjustment	external Teach-in
linearity error	± 160 µm
temperature drift	± 5 % (Full Scale)

## electrical data

response time (factory characteristic)	< 2,5 ms
response time (teach in characteristic)	< 3,1 ms
voltage supply range +Vs	15 ... 30 VDC
current consumption max. (no load)	20 mA
output circuit	voltage output / PNP
output signal	0 ... 10 VDC
load resistance	> 1000 Ohm
output current	< 10 mA (PNP)
voltage drop Vd	< 5 VDC (PNP)
short circuit protection	yes
reverse polarity protection	yes

## mechanical data

type	cylindrical threaded
housing material	brass nickel plated
dimension	30 mm
housing length	62 mm
connection types	connector M12

## ambient conditions

operating temperature	-10 ... +70 °C
protection class	IP 67

## photo



## connection diagram

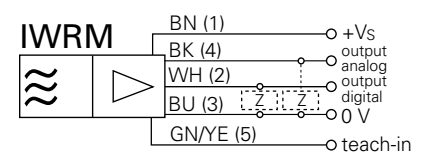

## installation drawing

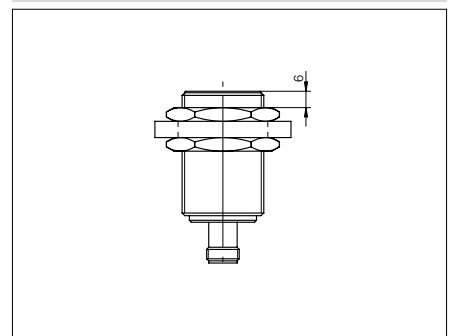

- external Teach-in
- Integrated Analog- and switching output
- Linear analog output