

features

- Available in various types of standard circuits in different sizes and power
- Higher temperature soldering of the leads prevents terminals from loosening during board assembly
- For automatic insertion machines, stick magazines and taping packages are available
- Marking: Black body color with white marking
- Products with lead-free terminations meet EU RoHS requirements. EU RoHS regulation is not intended for Pb-glass contained in electrode, resistor element and glass.

dimensions and construction

(See table below)

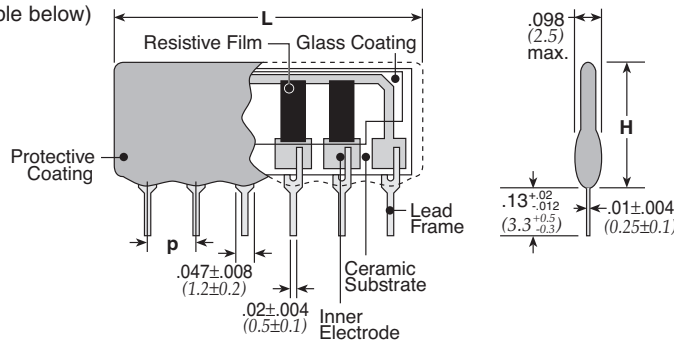

Size Code		Number of Pins														Dimen. in. (mm)	
		3	4	5	6	7	8	9	10	11	12	13	14	15	16	H max.	p
RKL	L	8.20	10.16	12.70	15.24	17.78	20.32	22.86	25.40	27.94	30.48	—	—	—	—	.200 (5.08)	.100±.008 (2.54±0.2)
	B,A,R circuit	250	375	500	625	750	875	1000	1050	1150	1250	—	—	—	—		
	C,T,E circuit	—	—	500	—	750	—	1000	—	1150	—	—	—	—	—		
	D circuit	—	—	375	500	625	750	875	1000	1125	1250	—	—	—	—		
	S Circuit	—	—	—	600	—	800	—	1000	—	1200	—	—	—	—		
RKC (2.54 pitch)	L	8.20	10.8	13.2	15.8	18.3	20.9	23.4	25.9	28.5	31.0	33.6	36.1	38.7	41.3	.256 (6.5)	.100±.008 (2.54±0.2)
	B,A,R circuit	250	375	500	625	750	875	1000	1050	1150	1250	1350	1450	1500	1550		
	C,T,E circuit	—	—	500	—	750	—	1000	—	1150	—	1350	—	—	—		
	D circuit	—	—	375	500	625	750	875	1000	1125	1250	1350	1450	—	—		
	S Circuit	—	500	—	750	—	1000	—	1050	—	1250	—	1450	—	—		
RKH	L	—	10.8	13.3	15.8	18.3	20.9	23.4	25.9	28.5	31.0	33.6	—	—	—	.421 (10.7)	.100±.008 (2.54±0.2)
	B,A,R circuit	—	525	700	875	1050	1250	1400	1500	1600	1700	1800	—	—	—		
	C,T,E circuit	—	—	700	—	1050	—	1400	—	1600	—	1800	—	—	—		
	D circuit	—	—	700	875	1050	1250	1400	1500	1600	1700	—	—	—	—		
	S Circuit	—	500	—	1050	—	1400	1400	1500	—	1700	—	—	—	—		
RKC (1.8 pitch)	L	—	10.2	10.8	12.7	15.5	15.8	17.8	20.4	20.9	23.5	25.4	28.5	—	—	.256 (6.5)	.071±.006 (1.8±0.15)
	W	—	300	400	500	580	650	720	760	820	850	880	900	—	—		
RKS (2.54 pitch)	L	—	10.1	12.7	12.7	15.3	17.8	20.3	22.8	22.8	25.4	—	—	—	—	.200 (5.08)	.079±.008 (2.0±0.2)
	W	—	195	260	325	390	455	520	585	650	715	—	—	—	—		

L = L dimension (mm) max. W = Wattage/Package (mW) max.

ordering information

New Part #	RKC	8	B	D	STP	103	F
Type	RKC RKH RKL	Number of Resistors 3 - 16	Circuit Symbol B, S, C, D, A, T, E, R RKC: L, K	Termination Material D: SnAgCu (Other termination styles available, contact factory for options)	Packaging STP, STB, TBA, TPA, TUA	Nominal Resistance 2 significant figures + 1 multiplier for ±2% & ±5% 3 significant figures + 1 multiplier for ±1% R1/R2 3 digits/3 digits	Tolerance F: ±1% G: ±2% J: ±5%

For further information on packaging, please refer to Appendix C.

Specifications given herein may be changed at any time without prior notice. Please confirm technical specifications before you order and/or use.

12/17/11

circuit schematics

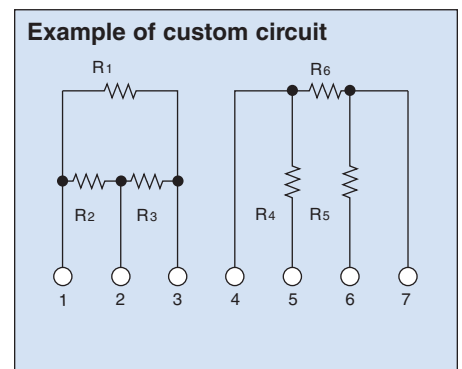
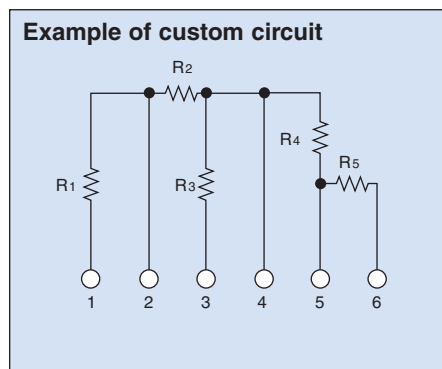
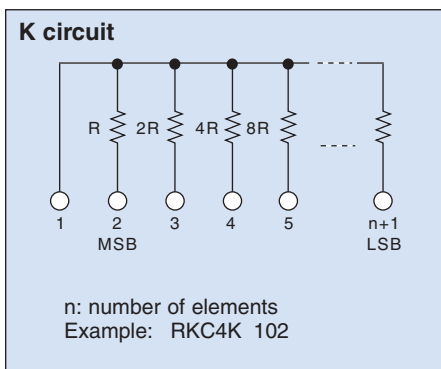
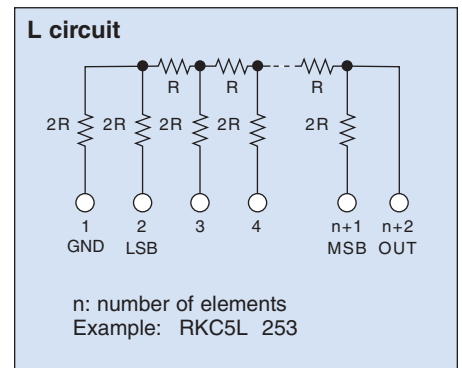
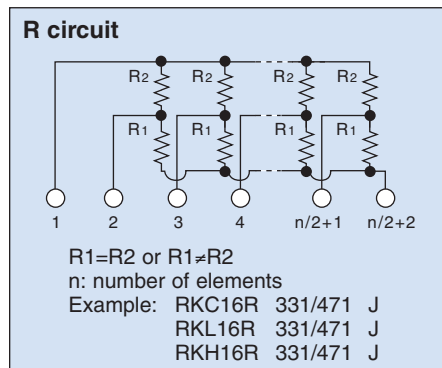
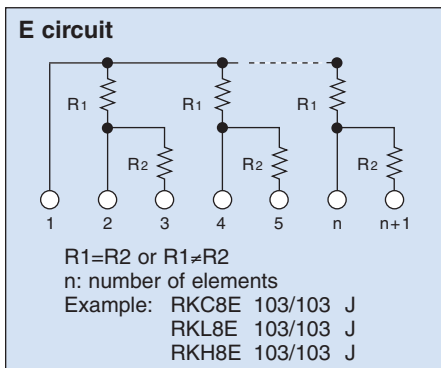
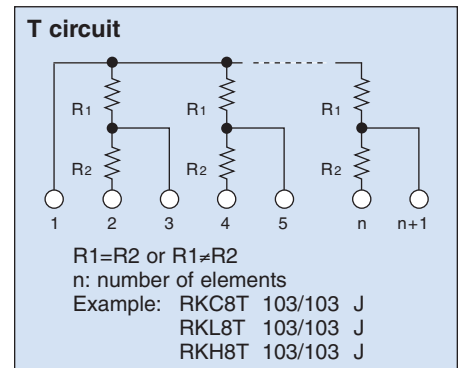
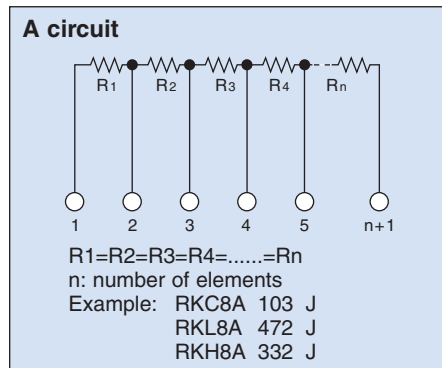
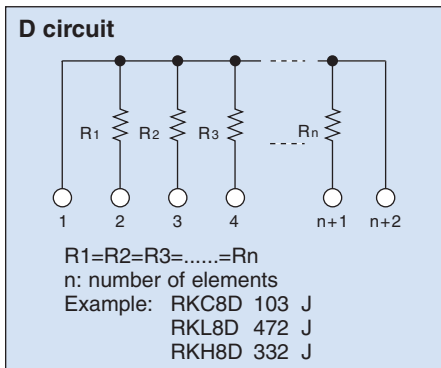
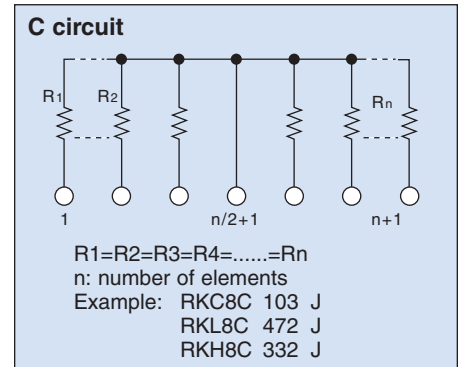
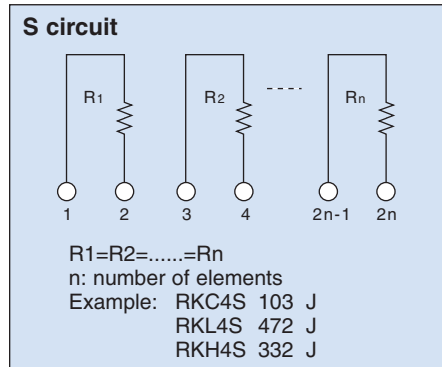
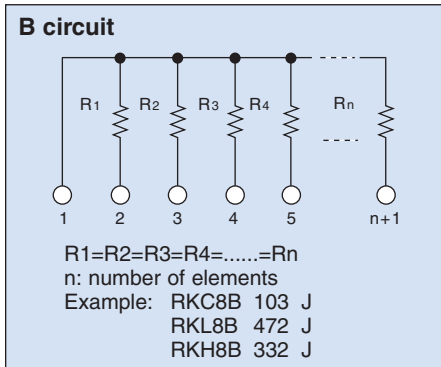

applications and ratings

Part Designation	Circuit Symbol	Number of Pins	Power Rating/Element	T.C.R. (ppm/°C) Max.	Resistance Range (Ω)	Resistance Tolerance	Maximum Working Voltage	Rated Ambient Temperature	Operating Temperature Range	
RKC	B	3-16	125mW	±200	22-2.2M (E24)	F: ±1% G: ±2% J: ±5%	200V	+70°C	-55°C to +155°C	
	C	5-13								
	D	5-14								
	A	4-14								
	T	5-13								
	E	5-13	250mW							
	S	4-16	125mW		100-100k (E24)	G: ±2% J: ±5%				
	R	4-16	20mW		±200	R=2.5k, 5k 10k, 25k 50k, 100k	±1/2LSB (Bit Error)	20V		+70°C
	L	6-11	40mW			R1(MSB):100 Min Rn(LSB):1M Max	±1/2LSB (Bit Error)			
RKL	B	3-12	125mW	±200	22-1M (E24)	F: ±1% G: ±2% J: ±5%	100V	+70°C	-55°C to +125°C	
	C	5-11								
	D	5-12								
	A	3-12								
	T	5-11								
	E	5-11	200mW							
	S	4-12	125mW		100-100k (E24)	G: ±2% J: ±5%				
RKH	B	4-13	125mW	±200	56-2.2M (E24)	F: ±1% G: ±2% J: ±5%	250V	+70°C	-55°C to +155°C	
	C	5-13								
	D	5-12								
	A	4-12								
	T	5-13								
	E	5-13	500mW							
	S	4-12	250mW		100-100k (E24)	G: ±2% J: ±5%				
Custom	RKL	3-12	0.1W 0.125W 0.25W 0.5W 1W	±100 ±150 ±200	10-1M	±0.5% ±1% ±2% ±5%	100V	+70°C	-55°C to +125°C	
	RKC (1.8 pitch)	4-14					50V			
	RKC (2.54 pitch)	3-16					200V			
	RKH	4-13					250V			
	RKS (2.0 pitch)	4-12					100V			

Rated voltage = $\sqrt{\text{power rating} \times \text{resistance value}}$ or max. working voltage, whichever is lower.

weight (g/1000 pcs)

	Number of Pins						
	3	4	5	6	7	8	9
RKL	147	185	228	271	314	357	400
RKC	160	217	273	330	387	444	501
RKH	—	416	511	606	701	796	891

	Number of Pins						
	10	11	12	13	14	15	16
RKL	443	486	529	—	—	—	—
RKC	558	615	672	728	785	842	893
RKH	986	1081	1176	1271	—	—	—

environmental applications

Derating Curve

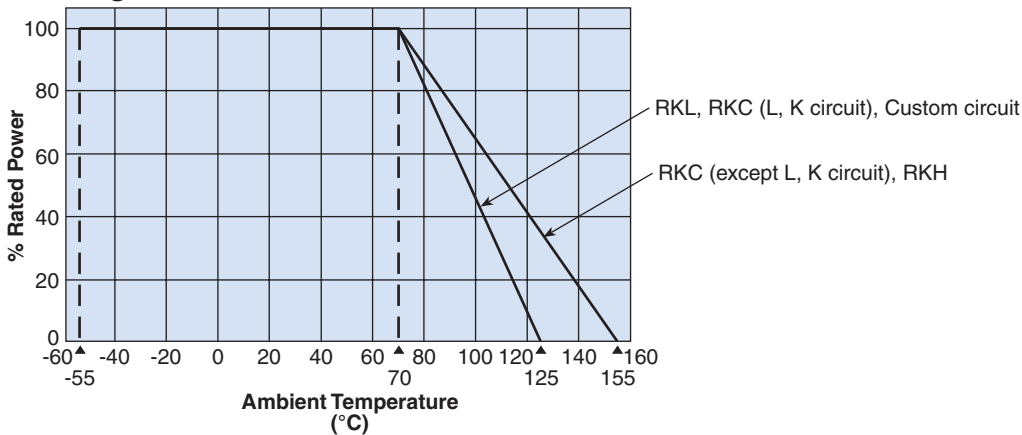

Performance Characteristics

Parameter	Requirement ΔR		Test Method
	Limit	Typical	
Resistance	Within specified tolerance	—	25°C
T.C.R.	Within specified T.C.R.	—	+25°C/-55°C, +25°C/+125°C (RKL) +25°C/-55°C, +25°C/+155°C (RKC, RKH)
Overload (Short time)	±0.5%	±0.25%	Rated voltage x 2.5 for 5 seconds
Resistance to Solder Heat	±0.5%	±0.25%	260°C ± 5°C, 10 seconds ± 1 second
Temperature Cycling	±0.5%	±0.25%	-40°C (30 minutes), +85°C (30 minutes), 5 cycles
Moisture Resistance	±2.0%	±1.0%	40°C ± 2°C, 90 - 95% RH, 1000 hours, 1.5 hr ON, 0.5 hr OFF cycle
Endurance at 70°C	±2.0%	±1.0%	70°C ± 2°C, 1000 hours, 1.5 hr ON, 0.5 hr OFF cycle