

NEW

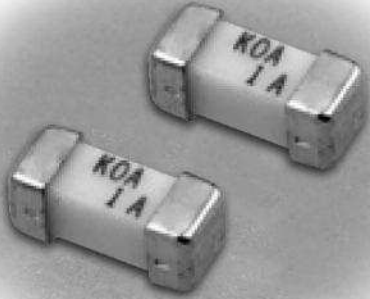

features

- Meets IEC60127-4 specifications
- Stable fusing characteristics due to original technology
- Suitable for reflow and flow soldering
- Marking: White body color with black marking
- Products meet EU RoHS requirements

dimensions and construction

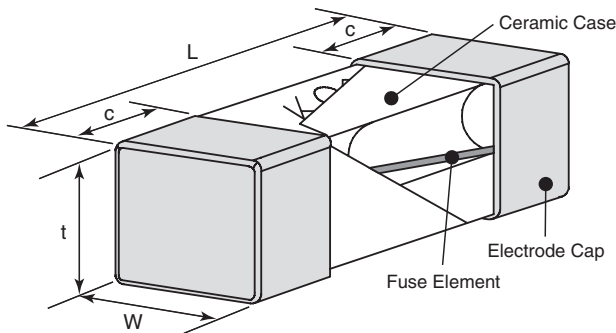

Type	Dimensions inches (mm)			
	L	W	t	c
CCF	.240±.008 (6.1±0.2)	.098±.008 (2.5±0.2)	.098±.008 (2.5±0.2)	.055±.008 (1.4±0.2)

ordering information

New Part #	CCF	1	F	1	T	TE
	Type	Style	Fusing Characteristic F: Fast-acting	Rated Current	Termination Surface Material T: Sn	Packaging TE: 4mm pitch plastic embossed BK: Bulk

applications and ratings

Part Designation	Current Rating	Voltage Rating	Interrupting Capacity	Fusing Characteristics		Internal R. (mΩ) Max.	Normal Melting I _t (A; sec.)	Operating Temperature Range
				Rated Current	Fusing Time			
CCF1F0.4	0.4A	UL(c-UL) AC 125V DC 125V	UL(c-UL) AC125V 50A DC125V 50A	UL(c-UL) 100% 200% 1000%	4 hour min. 120 sec. max. 0.001 sec. min. 0.01 sec. max.	650	0.024	-55°C to +125°C
CCF1F0.5	0.5A					510	0.030	
CCF1F0.63	0.63A					390	0.052	
CCF1F0.8	0.8A					250	0.125	
CCF1F1	1A					90.4	0.156	
CCF1F1.25	1.25A					75.9	0.220	
CCF1F1.6	1.6A					59.3	0.513	
CCF1F2	2A					42.9	0.814	
CCF1F2.5	2.5A					36.6	1.31	

For further information on packaging, please refer to Appendix A.

Specifications given herein may be changed at any time without prior notice. Please confirm technical specifications before you order and/or use.

1/27/12

applications and ratings (continued)

	Part Designation	Current Rating	Voltage Rating	Interrupting Capacity	Fusing Characteristics		Internal R. (mΩ) Max.	Normal Melting It (A², sec.)	Operating Temperature Range
					Rated Current	Fusing Time			
UNDER DEVELOP.	CCF1F3.15	3.15A	UL(c-UL) AC 125V DC 125V	UL(c-UL) AC125V 50A DC125V 50A	UL(c-UL) 100% 200%	4 hour min. 120 sec. max.	26.0	2.37	-55°C to +125°C
	CCF1F4	4A					20.1	3.85	
	CCF1F5	5A					15.3	6.5	
	CCF1F6.3	6.3A					11.4	10.6	
	CCF1F7	7A					10.6	12.8	
	CCF1F8	8A					9.5	17.0	
	CCF1F10	10A					7.5	27.7	
	CCF1F12	12A					4.5	73.5	
	CCF1F15	15A	3.5	125.5					

environmental applications

Derating Curve

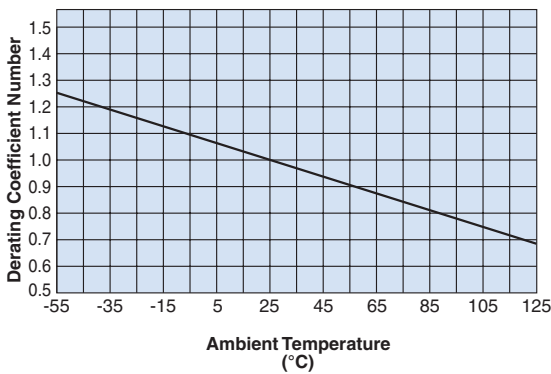

Normal derating of this product should be 0.7max. as standards. Deratings by ambient temperatures. When using the products at the temperatures other than normal temperature (25°C ± 5°), temperature adjustment will be required. Please refer the derating coefficient as shown in the figure.

Fusing Characteristics

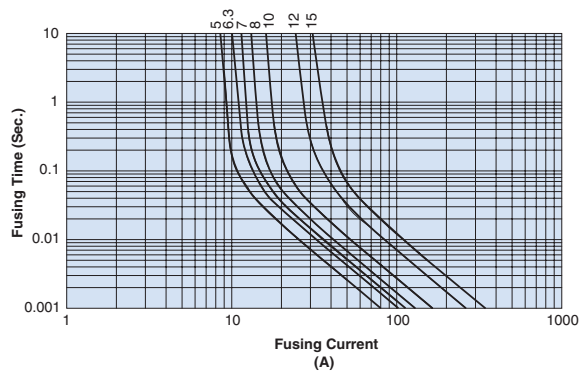

Performance Characteristics

Parameter	Requirements Limit	Ref.	Test
			Test Method
Fusing Characteristics	Within specified time. Insulation resistance shall not be less than 0.1MΩ	IEC60127-4 9.2	Fusing time measured under 2/N (rated current 200%) and 10/N (rated current 1000%)
Surface Temperature Rise	Maximum temperature rise 95K and not fusing	IEC60127-4 9.7	Surface temperature should be measured by 1.25/N
Voltage Drop	Refer to ratings table	IEC60127-4 9.1	When the fuse-link has carried its rated current for a time sufficient to reach temperature stability
Maximum Sustained Dissipation	Refer to ratings table	IEC60127-4 9.5	At the end of electrify test to 1.25/N the voltage drop across the fuse-link is measured and used for the calculation of the sustained dissipation
Bending Test	Shall not exceed the ratings table	IEC60127-4 8.3	Distance between holding points 90mm, bent by 1mm at rate of 1mm/second
Resistance to Soldering Heat	Shall not exceed the ratings table	IEC60127-4 8.7	260°C ± 5°C, 10 seconds ± 0.5 seconds, After the solder depth, voltage drop across the fuse-link is measured
Rapid Change of Temperature	ΔR±10%	—	-55°C (30 minutes), +125°C (30 minutes), 100 cycles