

features

- Virtually eliminates channel capacitance, a primary cause of reduced system performance
- Eases routing design of DDR SDRAM termination
- High precision $\pm 1\%$ is standard
- Saves board space and high density mounting
- Marking: Black body color with white marking (cut-out)
- Products with lead-free terminations meet EU RoHS requirements. EU RoHS regulation is not intended for Pb-glass contained in electrode, resistor element and glass.

dimensions and construction

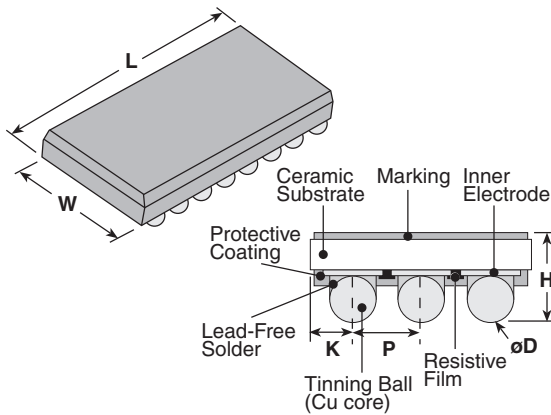

| Size Code | Dimensions inches (mm) | | | | | | Coplanarity |
|-----------|-------------------------|--------------------------|--------------------------|--------------------------|-------------------------|-------------------------|--------------------------|
| | P | ØD | K | H | L | W | |
| BR27A | .039±.010 (1.0±0.25) | .026±.002 (0.67±0.05) | .020±.010 (0.50±0.25) | .045±.006 (1.15±0.15) | .354±.006 (9.0±0.15) | .118±.006 (3.0±0.15) | .006 Max. (0.15 Max.) |
| BR36S | .039±.010 (1.0±0.25) | .026±.002 (0.67±0.05) | .020±.010 (0.50±0.25) | .045±.006 (1.15±0.15) | .087 Max. (9.0±0.15) | .157±.006 (4.0±0.15) | |

circuit schematic

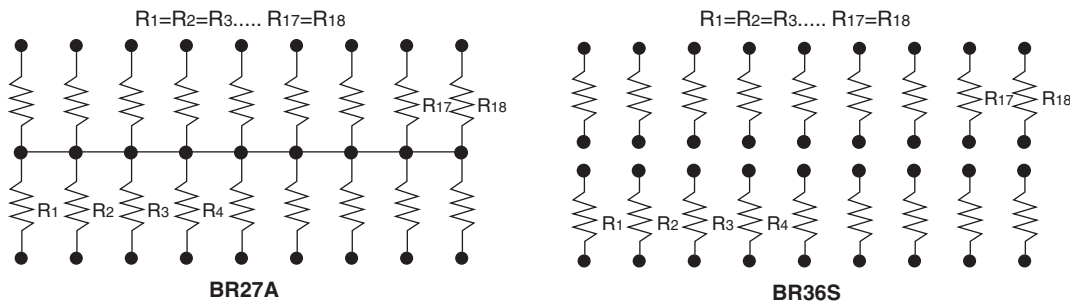

ordering information

| New Part # | BR | 27 | A | P | T | TEB | 1001 | F |
|----------------------|----|------------------------------------|------------------------------------|---------|-------|-------------------------------------|---|--------------|
| Type | BR | 27 | A | P | T | TEB | 1001 | F |
| Number of Terminals | | 27: 27 Terminal 36: 36 Terminal | | | | | | |
| Circuit Symbol | | | A: Parallel network S: Separate | | | | | |
| Terminal Pitch | | | | P: 1 mm | | | | |
| Termination Material | | | | | T: Sn | | | |
| Packaging | | | | | | TEB: 8 mm pitch embossed plastic | | |
| Nominal Resistance | | | | | | | $\pm 1\%$: 3 significant figures + multiplier "R" indicates decimal on values <100Ω | |
| Resistance Tolerance | | | | | | | | F: $\pm 1\%$ |

For further information on packaging, please refer to Appendix A.

Specifications given herein may be changed at any time without prior notice. Please confirm technical specifications before you order and/or use.

12/28/10

applications and ratings

| Part Designation | Number of Terminals | Circuit Symbol | Power Rating | Resistance Range (Ω) E-24 F: $\pm 1\%$ | T.C.R. (ppm/ $^{\circ}\text{C}$) | Maximum Working Voltage | Maximum Overload Voltage | Rated Ambient Temperature | Operating Temperature Range |
|------------------|---------------------|----------------|-----------------------------|---|-----------------------------------|-------------------------|--------------------------|---------------------------|--|
| BR | 27 | A | 0.05W/element 1W/package | 10-1K | ± 200 | 25V | 50V | +70 $^{\circ}\text{C}$ | -55 $^{\circ}\text{C}$ to +125 $^{\circ}\text{C}$ |
| | 36 | S | | | | | | | |

environmental applications

Derating Curve

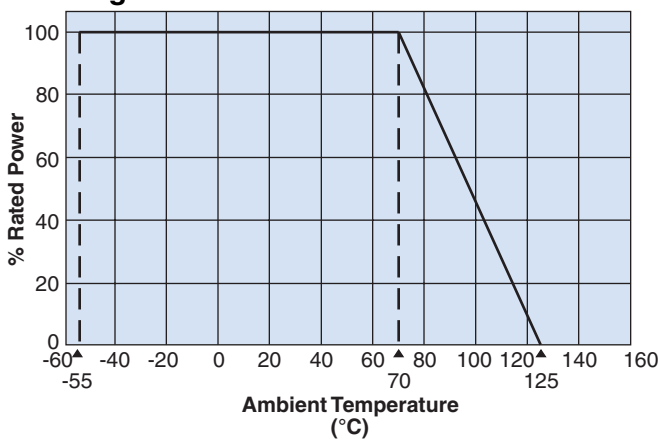

Performance Characteristics

| Parameter | Maximum $\Delta R \pm\%$ | Test Method |
|------------------------------------|-------------------------------|---|
| Resistance | 1% within specified tolerance | 25 $^{\circ}\text{C}$ |
| T.C.R. | Within specified T.C.R. | -55 $^{\circ}\text{C}$ /+125 $^{\circ}\text{C}$ |
| Short Time Overload | $\pm 0.5\%$ | Rated voltage times 2.5 for 5 seconds |
| Resistance to Soldering Heat | $\pm 0.5\%$ | 250 $^{\circ}\text{C} \pm 5^{\circ}\text{C}$, 30 seconds, 3 times |
| Rapid Change of Temperature | $\pm 0.5\%$ | -65 $^{\circ}\text{C}$ (30 min.)/+125 $^{\circ}\text{C}$ (30 min.) 5 cycles |
| Moisture Resistance | 1.0% | 0.1 Rated load, 85 $^{\circ}\text{C}$, 85% RH, 1000 hours |
| Endurance at 70 $^{\circ}\text{C}$ | 1.0% | 70 $^{\circ}\text{C}$, full load 2000h 1.5h ON/0.5h OFF cycle |
| Low Temperature Storage | 0.5% | -65 $^{\circ}\text{C}$, 24h, no load |
| High Temperature Exposure | 1.0% | 125 $^{\circ}\text{C}$, 1000h, no load |