

## Ultrasoft Recovery Rectifier Diode

### PRODUCT APPLICATIONS

- Anti-Parallel Diode
  - Switchmode Power Supply
  - Inverters
- Applications
  - Induction Heating
- Resonant Mode Circuits
  - ZVS and ZCS Topologies
  - Phase Shifted Bridge

### PRODUCT FEATURES

- Ultrasoft Recovery Times ( $t_r$ )
- Popular TO-247 Package or Surface Mount D<sup>3</sup>PAK Package
- Ultra Low Forward Voltage
- Low Leakage Current

### PRODUCT BENEFITS

- Soft Switching - High  $Q_r$
- Low Noise Switching
  - Reduced Ringing
- Higher Reliability Systems
- Minimizes or eliminates snubber

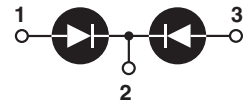
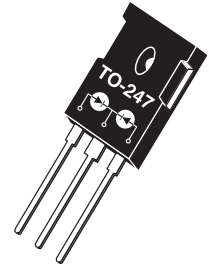

1 - Anode 1  
 2 - Common Cathode  
 Back of Case - Cathode  
 3 - Anode 2

### MAXIMUM RATINGS

All Ratings per leg :  $T_C = 25^\circ\text{C}$  unless otherwise specified.

Symbol	Characteristic / Test Conditions	Ratings	Unit
$V_R$	Maximum D.C. Reverse Voltage	600	Volts
$V_{RRM}$	Maximum Peak Repetitive Reverse Voltage		
$V_{RWM}$	Maximum Working Peak Reverse Voltage		
$I_{F(AV)}$	Maximum Average Forward current ( $T_C = 115^\circ\text{C}$ , Duty Cycle = 0.5)	50	Amps
$I_{F(RMS)}$	RMS Forward Current (Square wave, 50% duty)	150	
$I_{FSM}$	Non-Repetitive Forward Surge Current ( $T_J = 45^\circ\text{C}$ , 8.3 ms)	320	
$T_J, T_{STG}$	Operating and Storage Junction Temperature Range	-55 to 175	$^\circ\text{C}$
$T_L$	Lead Temperature for 10 Seconds	300	

### STATIC ELECTRICAL CHARACTERISTICS

Symbol	Characteristic / Test Conditions	Min	Typ	Max	Unit	
$V_F$	Forward Voltage		$I_F = 50\text{A}$	1.25	1.6	Volts
			$I_F = 100\text{A}$	2.0		
			$I_F = 50\text{A}, T_J = 125^\circ\text{C}$	1.25		
$I_{RM}$	Maximum Reverse Leakage Current		$V_R = 600\text{V}$		25	$\mu\text{A}$
			$V_R = 600\text{V}, T_J = 125^\circ\text{C}$		250	
$C_T$	Junction Capacitance, $V_R = 200\text{V}$		51		pF	

## DYNAMIC CHARACTERISTICS

APT50DL60BCT(G)

Symbol	Characteristic / Test Conditions	Min	Typ	Max	Unit
$t_{rr}$	Reverse Recovery Time $I_F = 1A, di_F/dt = -100A/\mu s, V_R = 30V, T_J = 25^\circ C$		52		ns
$t_{rr}$	Reverse Recovery Time		399		
$Q_{rr}$	Reverse Recovery Charge		1498		
$I_{RRM}$	Maximum Reverse Recovery Current		9		Amps
$t_{rr}$	Reverse Recovery Time		449		ns
$Q_{rr}$	Reverse Recovery Charge		3734		
$I_{RRM}$	Maximum Reverse Recovery Current		15		
$t_{rr}$	Reverse Recovery Time		284		ns
$Q_{rr}$	Reverse Recovery Charge		5134		
$I_{RRM}$	Maximum Reverse Recovery Current		34		

## THERMAL AND MECHANICAL CHARACTERISTICS

Symbol	Characteristic / Test Conditions	Min	Typ	Max	Unit
$R_{\theta JC}$	Junction-to-Case Thermal Resistance			0.63	$^\circ C/W$
$W_T$	Package Weight		0.22		oz
			5.9		g
Torque	Maximum Mounting Torque			10	lb-in
				1.1	N-m

Microsemi reserves the right to change, without notice, the specifications and information contained herein.

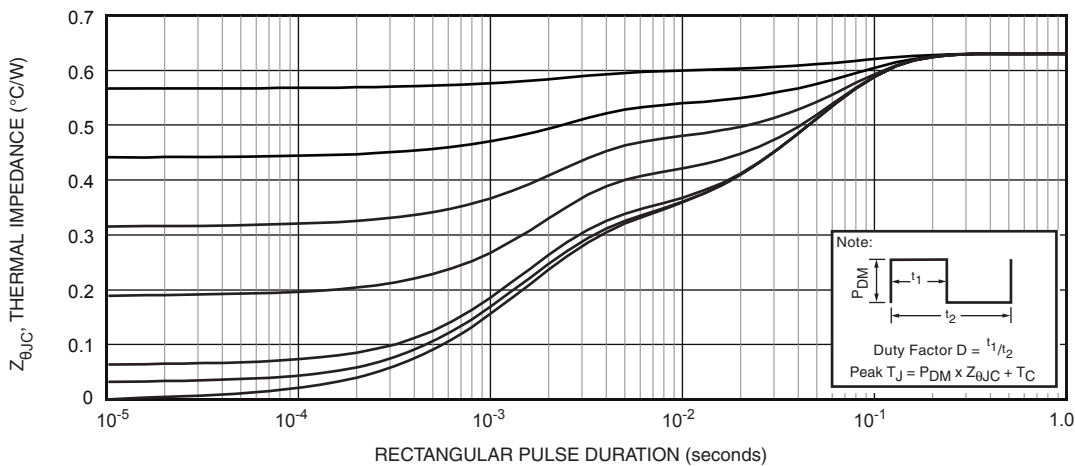

FIGURE 1a. MAXIMUM EFFECTIVE TRANSIENT THERMAL IMPEDANCE, JUNCTION-TO-CASE vs. PULSE DURATION

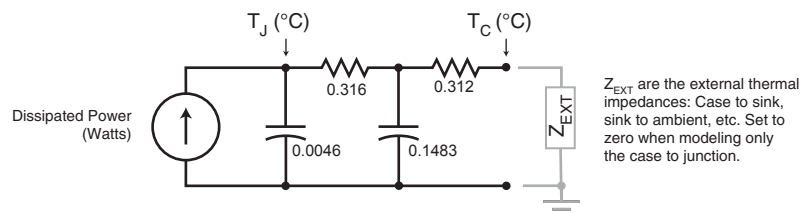
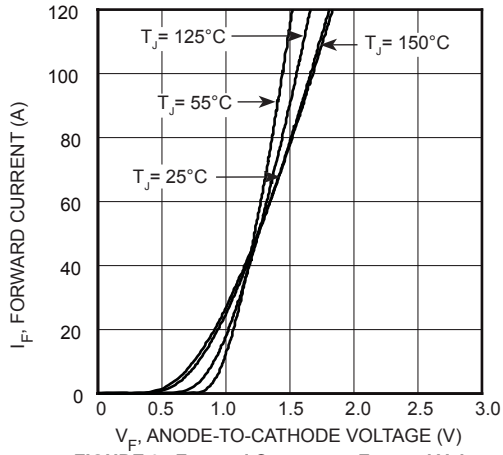

FIGURE 1b, TRANSIENT THERMAL IMPEDANCE MODEL

**TYPICAL PERFORMANCE CURVES**

**APT50DL60BCT(G)**



**FIGURE 2, Forward Current vs. Forward Voltage**

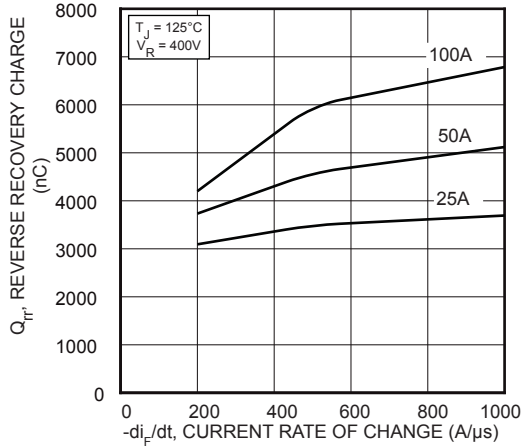

**FIGURE 4, Reverse Recovery Charge vs. Current Rate of Change**

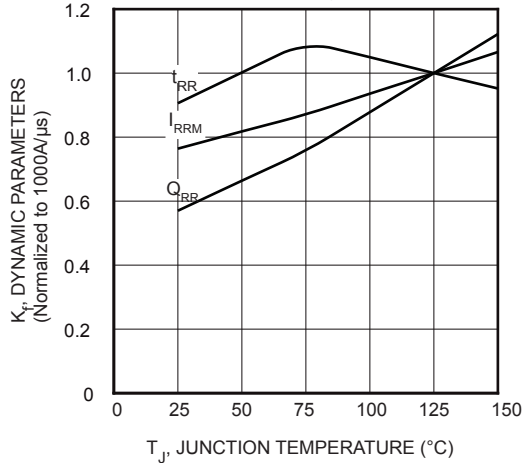

**FIGURE 6, Dynamic Parameters vs. Junction Temperature**

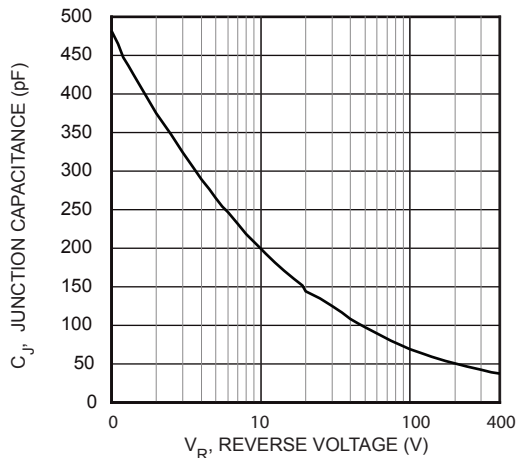

**FIGURE 8, Junction Capacitance vs. Reverse Voltage**

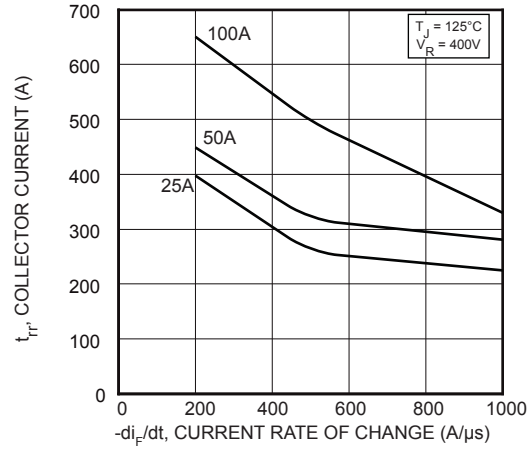

**FIGURE 3, Reverse Recovery Time vs. Current Rate of Change**

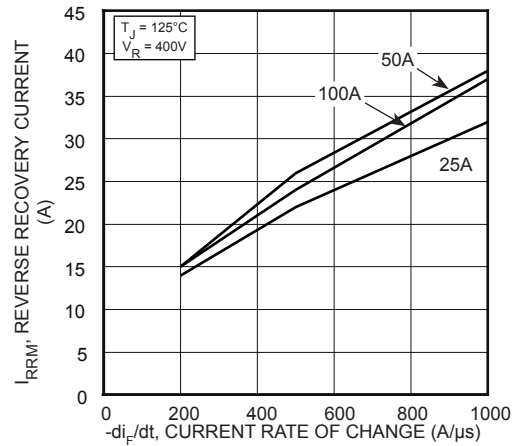

**FIGURE 5, Reverse Recovery Current vs. Current Rate of Change**

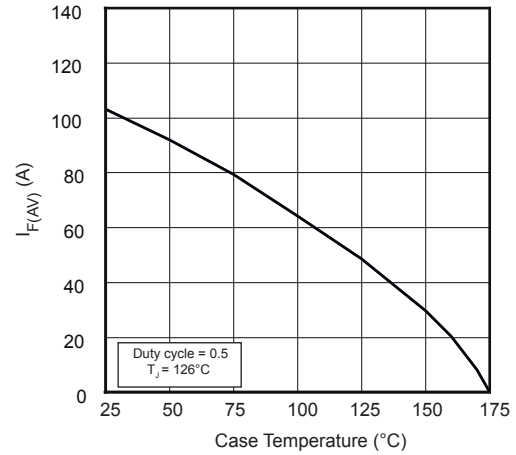

**FIGURE 7, Maximum Average Forward Current vs. Case Temperature**

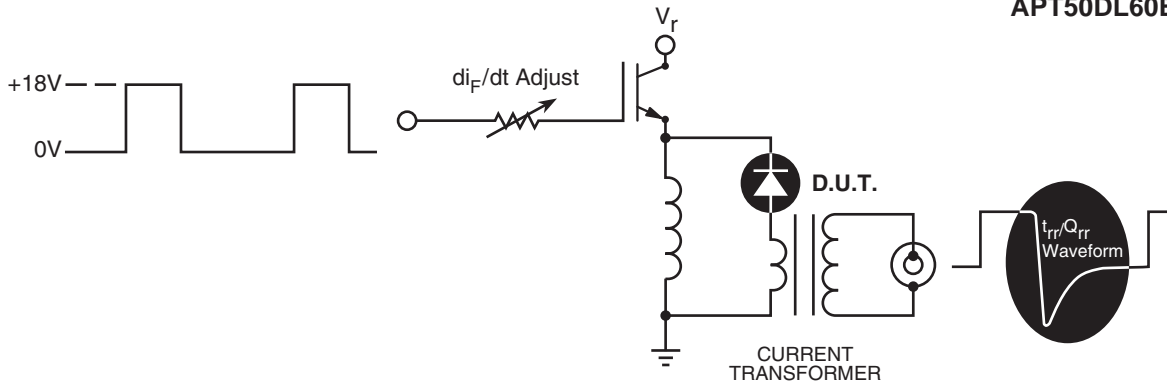

Figure 9. Diode Test Circuit

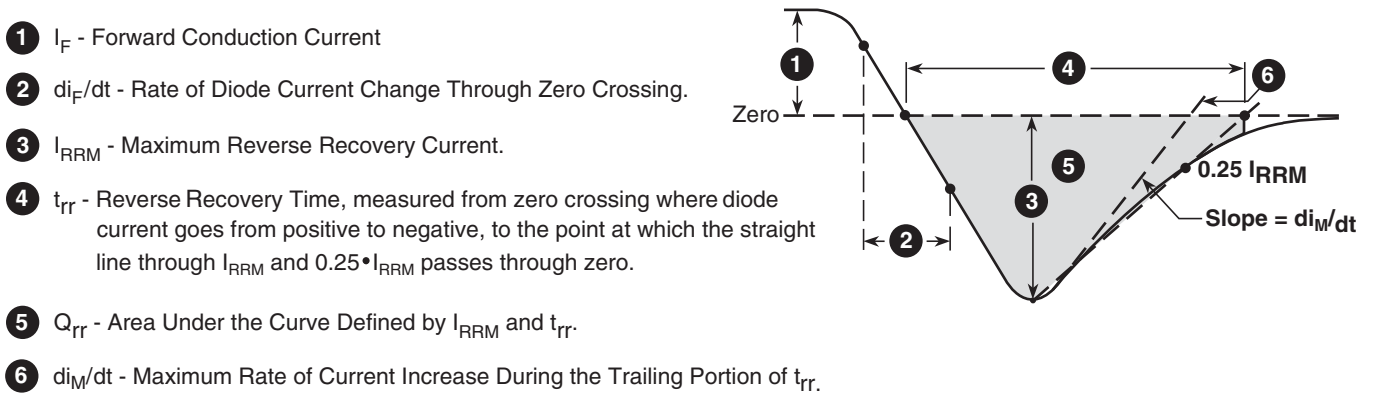
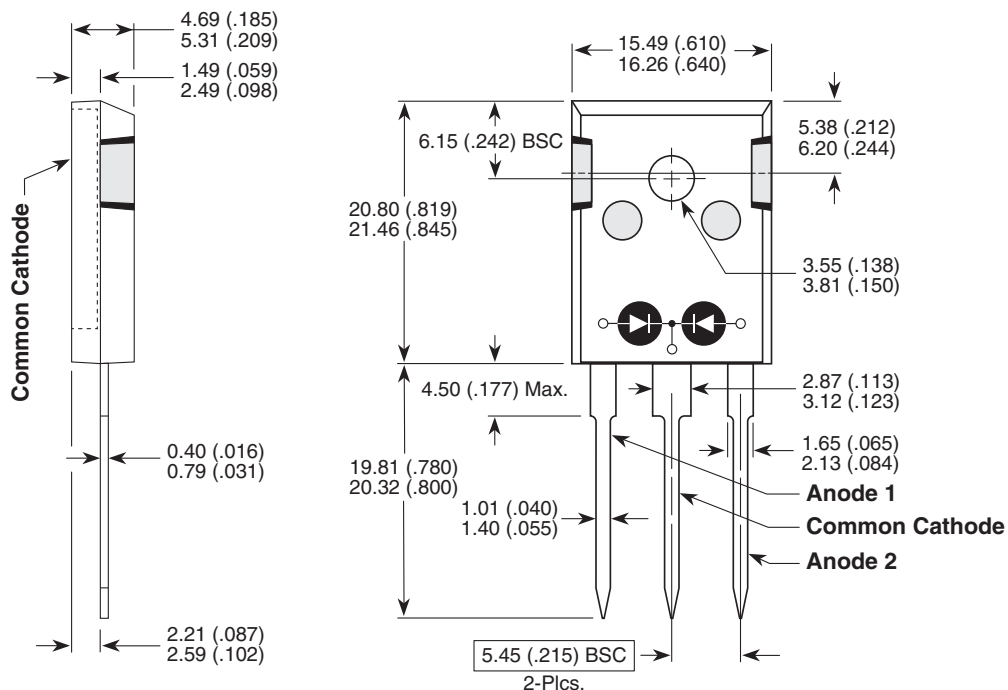

Figure 10, Diode Reverse Recovery Waveform and Definitions

TO-247 (BCT) Package Outline



Dimensions in Millimeters and (Inches)

Microsemi's products are covered by one or more of U.S. patents 4,895,810 5,045,903 5,089,434 5,182,234 5,019,522 5,262,336 6,503,786 5,256,583 4,748,103 5,283,202 5,231,474 5,434,095 5,528,058 6,939,743, 7,352,045 5,283,201 5,801,417 5,648,283 7,196,634 6,664,594 7,157,886 6,939,743 7,342,262 and foreign patents. US and Foreign patents pending. All Rights Reserved.