

# SYNCHRONOUS PWM CONTROLLER WITH CURRENT LIMIT, POWER GOOD & OVER VOLTAGE

**PRELIMINARY DATA SHEET**

**Pb Free Product**

## DESCRIPTION

The NX2116/2117 family of products are synchronous Buck controller IC designed for step down DC to DC converter applications. They are optimized to convert bus voltages from 2V to 25V to as low as 0.8V output voltage. The NX2116 and 2117 offer an Enable pin that can be used to program the converter's start up voltage using an external divider from bus voltage. These products operate at fixed internal frequency of 300kHz, except that NX2116A operates at 600kHz and 2116B at 1MHz frequency. These products employ loss-less current limiting protection by sensing the R<sub>ds(on)</sub> of synchronous MOSFET followed by latch out feature. Feedback under voltage triggers Hiccup.

Other features are; 5V gate drive, Power good indicator, Adaptive deadband control, Internal digital soft start; V<sub>cc</sub> undervoltage lock out and shutdown capability via the enable pin or comp pin.

## FEATURES

- Bus voltage operation from 2V to 25V
- Power Good indicator available in NX2116
- Fixed 300kHz, 600kHz and 1MHz for NX2116 and 300kHz, 600kHz for NX2117 family.
- Internal Digital Soft Start Function
- Less than 50 nS adaptive deadband
- Enable pin to program BUS UVLO for NX2116/2117
- Programmable current limit triggers latch out by sensing R<sub>ds(on)</sub> of Synchronous MOSFET
- No negative spike at V<sub>out</sub> during startup and shutdown

## APPLICATIONS

- Graphic Card on board converters
- Memory V<sub>ddq</sub> Supply
- On board DC to DC such as 2V to 3.3V, 2.5V or 1.8V
- ADSL Modem

## TYPICAL APPLICATION

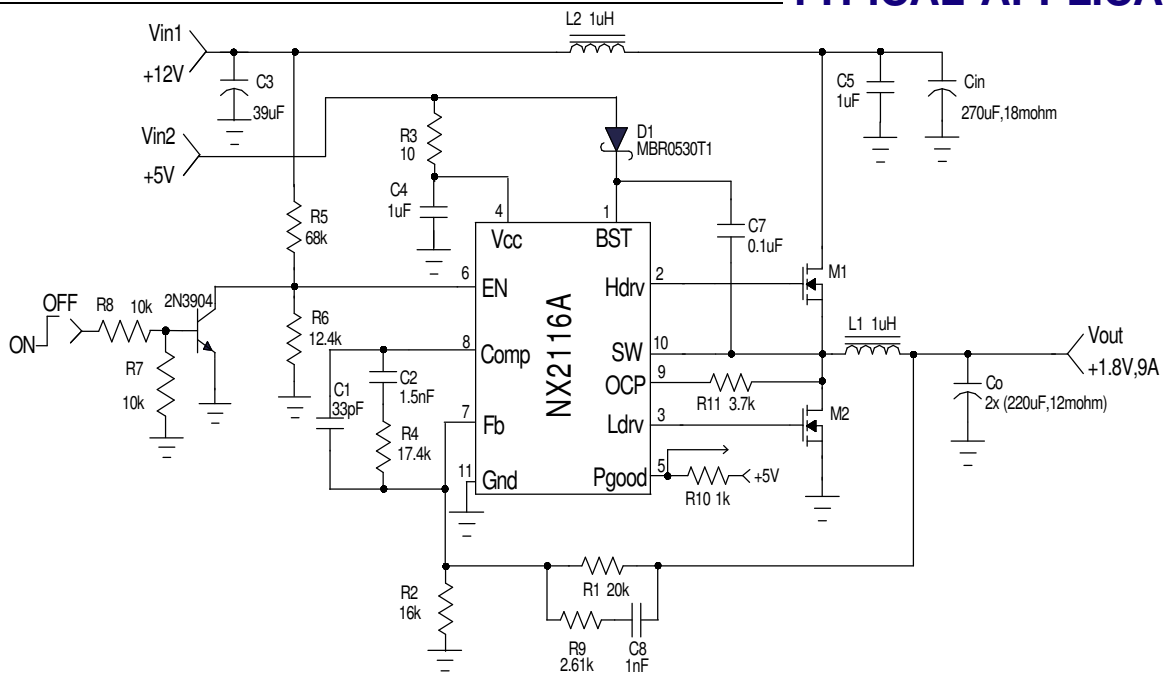

Figure 1 - Typical application of 2116

## ORDERING INFORMATION

| Device      | Temperature | Package  | Frequency | Pb-Free |
|-------------|-------------|----------|-----------|---------|
| NX2116CMTR  | 0 to 70°C   | MLPD-10L | 300kHz    | Yes     |
| NX2116ACMTR | 0 to 70°C   | MLPD-10L | 600kHz    | Yes     |
| NX2116BCMTR | 0 to 70°C   | MLPD-10L | 1MHz      | Yes     |
| NX2117CUTR  | 0 to 70°C   | MSOP-10L | 300kHz    | Yes     |
| NX2117ACUTR | 0 to 70°C   | MSOP-10L | 600kHz    | Yes     |

## ABSOLUTE MAXIMUM RATINGS

|  |                           |
|--|---------------------------|
| VCC to GND & BST to SW voltage .....       | -0.3V to 6.5V             |
| BST to GND Voltage .....                   | -0.3V to 35V              |
| SW to GND .....                            | -2V to 35V                |
| All other pins .....                       | -0.3V to VCC+0.3V or 6.5V |
| Storage Temperature Range .....            | -65°C to 150°C            |
| Operating Junction Temperature Range ..... | -40°C to 125°C            |
| ESD Susceptibility .....                   | 2kV                       |

CAUTION: Stresses above those listed in "ABSOLUTE MAXIMUM RATINGS", may cause permanent damage to the device. This is a stress only rating and operation of the device at these or any other conditions above those indicated in the operational sections of this specification is not implied.

## PACKAGE INFORMATION

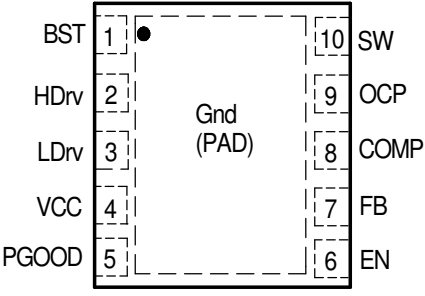
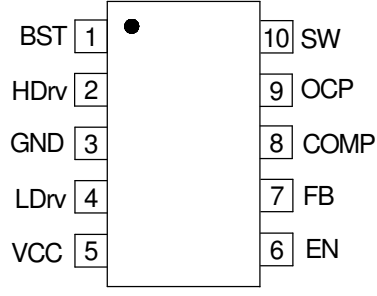
| NX2116/2116A/2116B<br>10-LEAD PLASTIC MLPD   | NX2117/2117A<br>10-LEAD PLASTIC MSOP  |
|--|---|
| $\theta_{JA} \approx 52^{\circ}\text{C/W}$   | $\theta_{JA} \approx 200^{\circ}\text{C/W}$   |
|  |  |

## ELECTRICAL SPECIFICATIONS

Unless otherwise specified, these specifications apply over Vcc = 5V, and T<sub>A</sub> = 0 to 70°C. Typical values refer to T<sub>A</sub> = 25°C. Low duty cycle pulse testing is used which keeps junction and case temperatures equal to the ambient temperature.

| PARAMETER                                 | SYM                        | Test Condition                                      | Min | TYP | MAX | Units |
|---|----------------------------|---|-----|-----|-----|-------|
| <b>Reference Voltage</b>                  |                            |   |     |     |     |       |
| Ref Voltage                               | V <sub>REF</sub>           |   |     | 0.8 |     | V     |
| Ref Voltage line regulation               |                            |   |     | 0.2 |     | %     |
| <b>Supply Voltage(Vcc)</b>                |                            |   |     |     |     |       |
| V <sub>CC</sub> Voltage Range             | V <sub>CC</sub>            |   | 4.5 | 5   | 5.5 | V     |
| V <sub>CC</sub> Supply Current (Static)   | I <sub>CC</sub> (Static)   | Outputs not switching                               |     | 3   |     | mA    |
| V <sub>CC</sub> Supply Current (Dynamic)  | I <sub>CC</sub> (Dynamic)  | C <sub>LOAD</sub> =3300pF<br>F <sub>S</sub> =300kHz |     | TBD |     | mA    |
| <b>Supply Voltage(V<sub>BST</sub>)</b>    |                            |   |     |     |     |       |
| V <sub>BST</sub> Supply Current (Static)  | I <sub>BST</sub> (Static)  | Outputs not switching                               |     | TBD |     | mA    |
| V <sub>BST</sub> Supply Current (Dynamic) | I <sub>BST</sub> (Dynamic) | C <sub>LOAD</sub> =3300pF<br>F <sub>S</sub> =300kHz |     | TBD |     | mA    |

| PARAMETER                                  | SYM                        | Test Condition                              | Min | TYP  | MAX | Units |
|--|----------------------------|---|-----|------|-----|-------|
| <b>Under Voltage Lockout</b>               |                            |   |     |      |     |       |
| V <sub>CC</sub> -Threshold                 | V <sub>CC_UVLO</sub>       | V <sub>CC</sub> Rising                      | 3.8 | 4    | 4.2 | V     |
| V <sub>CC</sub> -Hysteresis                | V <sub>CC_Hyst</sub>       | V <sub>CC</sub> Falling                     |     | 0.2  |     | V     |
| <b>Oscillator</b>                          |                            |   |     |      |     |       |
| Frequency                                  | F <sub>S</sub>             | 2116, 2117                                  |     | 300  |     | kHz   |
|  |                            | 2116A,2117A                                 |     | 600  |     | kHz   |
|  |                            | 2116B                                       |     | 1000 |     | kHz   |
| Ramp-Amplitude Voltage                     | V <sub>RAMP</sub>          |   |     | 1.5  |     | V     |
| Max Duty Cycle                             |                            |   |     | 95   |     | %     |
| Min Duty Cycle                             |                            |   |     |      | 0   | %     |
| <b>Error Amplifiers</b>                    |                            |   |     |      |     |       |
| Transconductance                           |                            |   |     | 2000 |     | umho  |
| Input Bias Current                         | I <sub>b</sub>             |   |     | 10   |     | nA    |
| <b>EN &amp; SS</b>                         |                            |   |     |      |     |       |
| Soft Start time                            | T <sub>ss</sub>            | NX2116,NX2117                               |     | 6.8  |     | mS    |
|  |                            | NX2116A, NX2117A                            |     |      |     |       |
|  |                            | NX2116B                                     |     |      |     |       |
| Enable HI Threshold                        |                            |   |     | 1.25 |     | V     |
| Enable Hysteresis                          |                            |   |     | 150  |     | mV    |
| <b>High Side Driver (CL=3300pF)</b>        |                            |   |     |      |     |       |
| Output Impedance , Sourcing Current        | R <sub>source</sub> (Hdrv) | I=200mA                                     |     | 0.9  |     | ohm   |
| Output Impedance , Sinking Current         | R <sub>sink</sub> (Hdrv)   | I=200mA                                     |     | 0.65 |     | ohm   |
| Rise Time                                  | T <sub>Hdrv</sub> (Rise)   | V <sub>BST</sub> -V <sub>SW</sub> =4.5V     |     | 50   |     | ns    |
| Fall Time                                  | T <sub>Hdrv</sub> (Fall)   | V <sub>BST</sub> -V <sub>SW</sub> =4.5V     |     | 50   |     | ns    |
| Deadband Time                              | T <sub>dead</sub> (L to H) | Ldrv going Low to Hdrv going High, 10%-10%  |     | 30   |     | ns    |
| <b>Low Side Driver (CL=3300pF)</b>         |                            |   |     |      |     |       |
| Output Impedance, Sourcing Current         | R <sub>source</sub> (Ldrv) | I=200mA                                     |     | 0.9  |     | ohm   |
| Output Impedance, Sinking Current          | R <sub>sink</sub> (Ldrv)   | I=200mA                                     |     | 0.5  |     | ohm   |
| Rise Time                                  | T <sub>Ldrv</sub> (Rise)   | 10% to 90%                                  |     | 50   |     | ns    |
| Fall Time                                  | T <sub>Ldrv</sub> (Fall)   | 90% to 10%                                  |     | 50   |     | ns    |
| Deadband Time                              | T <sub>dead</sub> (H to L) | SW going Low to Ldrv going High, 10% to 10% |     | 30   |     | ns    |
| <b>OCP Adjust</b>                          |                            |   |     |      |     |       |
| OCP current                                |                            |   |     | 40   |     | uA    |
| <b>Power Good(Pgood)</b>                   |                            |   |     |      |     |       |
| Threshold Voltage as % of V <sub>ref</sub> |                            | FB ramping up                               |     | 90   |     | %     |
| Hysteresis                                 |                            |   |     | 5    |     | %     |

## PIN DESCRIPTIONS

| PIN SYMBOL | PIN DESCRIPTION   |
|------------|---|
| VCC        | Power supply voltage. A high freq 1uF ceramic capacitor is placed as close as possible to and connected to this pin and ground pin. The maximum rating of this pin is 5V.   |
| BST        | This pin supplies voltage to high side FET driver. A high freq 0.1uF ceramic capacitor is placed as close as possible to and connected to these pins and respected SW pins.   |
| GND        | Ground pin.   |
| FB         | This pin is the error amplifier inverting input. It is connected via resistor divider to the output of the switching regulator to set the output DC voltage. When FB pin voltage is lower than 0.6V, hiccup circuit starts to recycle the soft start circuit after 2048 switching cycles.   |
| OCP        | This pin is connected to the drain of the external low side MOSFET via resistor and is the input of the over current protection(OCP) comparator. An internal current source 40uA is flown to the external resistor which sets the OCP voltage across the Rds-on of the low side MOSFET. Current limit point is this voltage divided by the Rds-on. Once this threshold is reached the Hdrv and Ldrv pins are latched out. |
| SW         | This pin is connected to source of high side FET and provides return path for the high side driver. It is also used to hold the low side driver low until this pin is brought low by the action of high side turning off. LDRV can only go high if SW is below 1V threshold .   |
| HDRV       | High side gate driver output.   |
| LDRV       | Low side gate driver output.  |
| PGOOD      | An open drain output that requires a pull up resistor to Vcc or a voltage lower than Vcc. When FB pin reaches 90% of the reference voltage PGOOD transitions from LO to HI state.   |
| EN         | A resistor divider is connected from the respective switcher BUS voltages to these pins that holds off the controller's soft start until this threshold is reached. An external low cost Transistor can be connected to this pin for external enable control.   |
| COMP       | This pin is the output of error amplifier and is used to compensate the voltage control feedback loop. This pin can also be used to perform a shutdown if pulled lower than 0.3V.   |

## BLOCK DIAGRAM

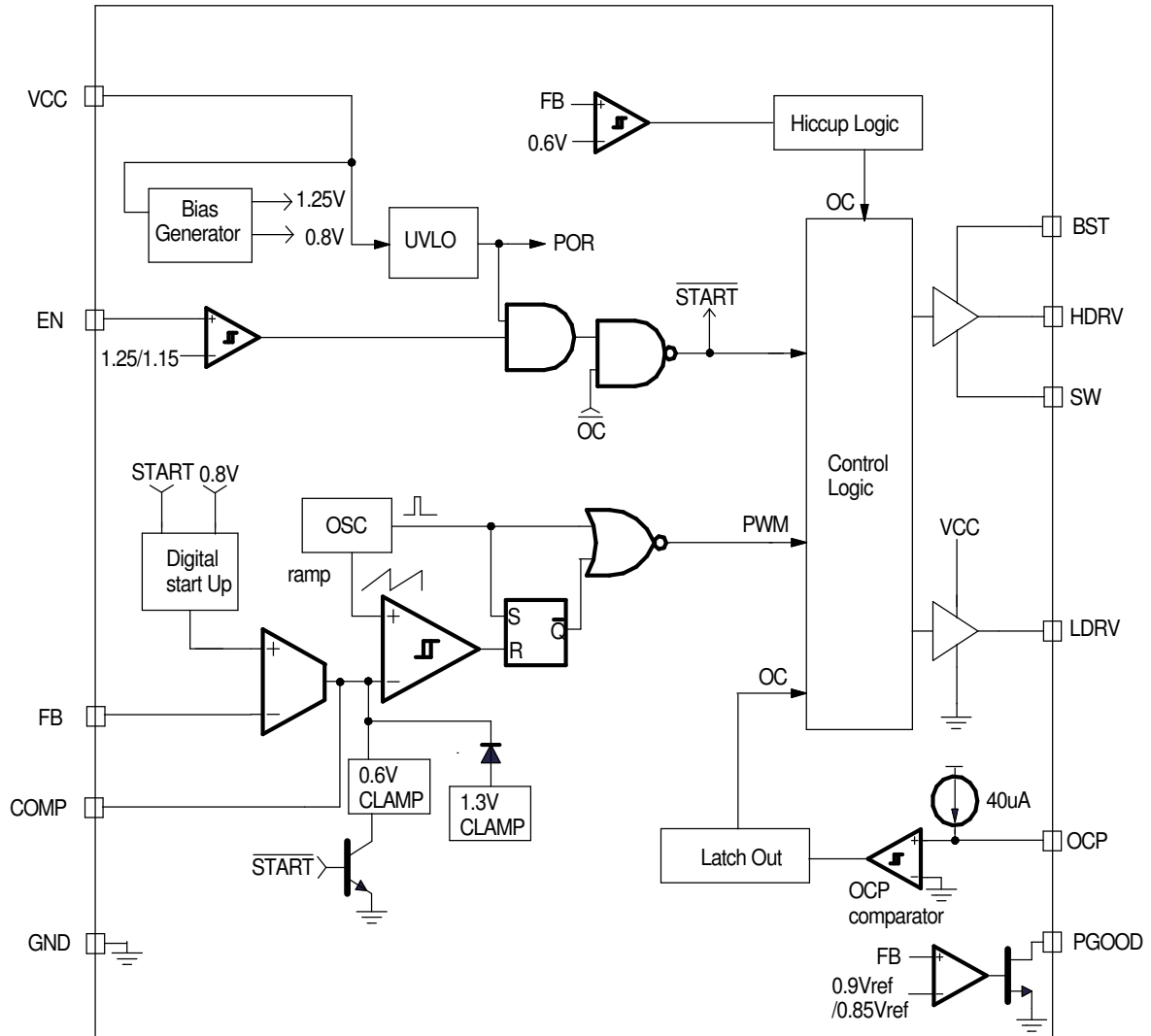

Figure 2 - Simplified block diagram of the NX2116

## APPLICATION INFORMATION

### Symbol Used In Application Information:

- $V_{IN}$  - Input voltage
- $V_{OUT}$  - Output voltage
- $I_{OUT}$  - Output current
- $\Delta V_{RIPPLE}$  - Output voltage ripple
- $F_S$  - Working frequency
- $\Delta I_{RIPPLE}$  - Inductor current ripple

### Design Example

The following is typical application for NX2116A, the schematic is figure 1.

- $V_{IN} = 12V$
- $V_{OUT} = 1.8V$
- $F_S = 600kHz$
- $I_{OUT} = 9A$
- $\Delta V_{RIPPLE} \leq 20mV$
- $\Delta V_{DROOP} \leq 100mV @ 9A \text{ step}$

### Output Inductor Selection

The selection of inductor value is based on inductor ripple current, power rating, working frequency and efficiency. Larger inductor value normally means smaller ripple current. However if the inductance is chosen too large, it brings slow response and lower efficiency. Usually the ripple current ranges from 20% to 40% of the output current. This is a design freedom which can be decided by design engineer according to various application requirements. The inductor value can be calculated by using the following equations:

$$L_{OUT} = \frac{V_{IN} - V_{OUT}}{\Delta I_{RIPPLE}} \times \frac{V_{OUT}}{V_{IN}} \times \frac{1}{F_S} \quad \dots(1)$$

$$I_{RIPPLE} = k \times I_{OUTPUT}$$

where k is between 0.2 to 0.4.

Select  $k=0.3$ , then

$$L_{OUT} = \frac{12V - 1.8V}{0.3 \times 9A} \times \frac{1.8V}{12V} \times \frac{1}{600kHz}$$

$$L_{OUT} = 0.94\mu H$$

Choose inductor from COILCRAFT DO3316P-102HC with  $L=1\mu H$  is a good choice.

Current Ripple is recalculated as

$$\Delta I_{RIPPLE} = \frac{V_{IN} - V_{OUT}}{L_{OUT}} \times \frac{V_{OUT}}{V_{IN}} \times \frac{1}{F_S}$$

$$= \frac{12V - 1.8V}{1\mu H} \times \frac{1.8V}{12V} \times \frac{1}{600kHz} = 2.55A \quad \dots(2)$$

### Output Capacitor Selection

Output capacitor is basically decided by the amount of the output voltage ripple allowed during steady state(DC) load condition as well as specification for the load transient. The optimum design may require a couple of iterations to satisfy both condition.

#### Based on DC Load Condition

The amount of voltage ripple during the DC load condition is determined by equation(3).

$$\Delta V_{RIPPLE} = ESR \times \Delta I_{RIPPLE} + \frac{\Delta I_{RIPPLE}}{8 \times F_S \times C_{OUT}} \quad \dots(3)$$

Where ESR is the output capacitors' equivalent series resistance,  $C_{OUT}$  is the value of output capacitors.

Typically when large value capacitors are selected such as Aluminum Electrolytic, POSCAP and OSCON types are used, the amount of the output voltage ripple is dominated by the first term in equation(3) and the second term can be neglected.

For this example, POSCAP are chosen as output capacitors, the ESR and inductor current typically determines the output voltage ripple.

$$ESR_{desire} = \frac{\Delta V_{RIPPLE}}{\Delta I_{RIPPLE}} = \frac{20mV}{2.55A} = 7.8m\Omega \quad \dots(4)$$

If low ESR is required, for most applications, multiple capacitors in parallel are better than a big capacitor. For example, for 20mV output ripple, POSCAP 2R5TPE220MC with 12m $\Omega$  are chosen.

$$N = \frac{ESR_E \times \Delta I_{RIPPLE}}{\Delta V_{RIPPLE}} \quad \dots(5)$$

Number of Capacitor is calculated as

$$N = \frac{12m\Omega \times 2.56A}{20mV}$$

$$N = 1.5$$

The number of capacitor has to be round up to a integer. Choose  $N=2$ .

If ceramic capacitors are chosen as output ca

capacitors, both terms in equation (3) need to be evaluated to determine the overall ripple. Usually when this type of capacitors are selected, the amount of capacitance per single unit is not sufficient to meet the transient specification, which results in parallel configuration of multiple capacitors .

For example, one 100uF, X5R ceramic capacitor with 2mΩ ESR is used. The amount of output ripple is

$$\Delta V_{\text{RIPPLE}} = 2\text{m}\Omega \times 2.55\text{A} + \frac{2.56\text{A}}{8 \times 600\text{kHz} \times 100\mu\text{F}}$$

$$= 10.4\text{mV}$$

Although this meets DC ripple spec, however it needs to be studied for transient requirement.

### Based On Transient Requirement

Typically, the output voltage droop during transient is specified as:

$$\Delta V_{\text{DROOP}} < \Delta V_{\text{TRAN}} \text{ @ step load } \Delta I_{\text{STEP}}$$

During the transient, the voltage droop during the transient is composed of two sections. One Section is dependent on the ESR of capacitor, the other section is a function of the inductor, output capacitance as well as input, output voltage. For example, for the overshoot, when load from high load to light load with a  $\Delta I_{\text{STEP}}$  transient load, if assuming the bandwidth of system is high enough, the overshoot can be estimated as the following equation.

$$\Delta V_{\text{overshoot}} = \text{ESR} \times \Delta I_{\text{step}} + \frac{V_{\text{OUT}}}{2 \times L \times C_{\text{OUT}}} \times \tau^2 \quad \dots(6)$$

where  $\tau$  is the a function of capacitor, etc.

$$\tau = \begin{cases} 0 & \text{if } L \leq L_{\text{crit}} \\ \frac{L \times \Delta I_{\text{step}}}{V_{\text{OUT}}} - \text{ESR} \times C_{\text{OUT}} & \text{if } L \geq L_{\text{crit}} \end{cases} \quad \dots(7)$$

where

$$L_{\text{crit}} = \frac{\text{ESR} \times C_{\text{OUT}} \times V_{\text{OUT}}}{\Delta I_{\text{step}}} = \frac{\text{ESR}_E \times C_E \times V_{\text{OUT}}}{\Delta I_{\text{step}}} \quad \dots(8)$$

where  $\text{ESR}_E$  and  $C_E$  represents ESR and capacitance of each capacitor if multiple capacitors are used in parallel.

The above equation shows that if the selected output inductor is smaller than the critical inductance, the voltage droop or overshoot is only dependent on the ESR

of output capacitor. For low frequency capacitor such as electrolytic capacitor, the product of ESR and capacitance is high and  $L \leq L_{\text{crit}}$  is true. In that case, the transient spec is dependent on the ESR of capacitor.

In most cases, the output capacitors are multiple capacitors in parallel. The number of capacitors can be calculated by the following

$$N = \frac{\text{ESR}_E \times \Delta I_{\text{step}}}{\Delta V_{\text{tran}}} + \frac{V_{\text{OUT}}}{2 \times L \times C_E \times \Delta V_{\text{tran}}} \times \tau^2 \quad \dots(9)$$

where

$$\tau = \begin{cases} 0 & \text{if } L \leq L_{\text{crit}} \\ \frac{L \times \Delta I_{\text{step}}}{V_{\text{OUT}}} - \text{ESR}_E \times C_E & \text{if } L \geq L_{\text{crit}} \end{cases} \quad \dots(10)$$

For example, assume voltage droop during transient is 100mV for 9A load step.

If the POSCAP 2R5TPE220MC(220uF, 12mΩ) is used, the critical inductance is given as

$$L_{\text{crit}} = \frac{\text{ESR}_E \times C_E \times V_{\text{OUT}}}{\Delta I_{\text{step}}}$$

$$\frac{12\text{m}\Omega \times 220\mu\text{F} \times 1.8\text{V}}{9\text{A}} = 0.56\mu\text{H}$$

The selected inductor is 1uH which is bigger than critical inductance. In that case, the output voltage transient not only dependent on the ESR, but also capacitance.

number of capacitors is

$$\tau = \frac{L \times \Delta I_{\text{step}}}{V_{\text{OUT}}} - \text{ESR}_E \times C_E$$

$$= \frac{1\mu\text{H} \times 9\text{A}}{1.8\text{V}} - 12\text{m}\Omega \times 220\mu\text{F} = 2.36\mu\text{s}$$

$$N = \frac{\text{ESR}_E \times \Delta I_{\text{step}}}{\Delta V_{\text{tran}}} + \frac{V_{\text{OUT}}}{2 \times L \times C_E \times \Delta V_{\text{tran}}} \times \tau^2$$

$$= \frac{12\text{m}\Omega \times 9\text{A}}{100\text{mV}} + \frac{1.8\text{V}}{2 \times 1\mu\text{H} \times 220\mu\text{F} \times 100\text{mV}} \times (2.36\mu\text{s})^2$$

$$= 1.3$$

The number of capacitors has to satisfied both ripple and transient requirement. Overall, we can choose N=2.

It should be considered that the proposed equation is based on ideal case, in reality, the droop or overshoot is typically more than the calculation. The equation gives a good start. For more margin, more capacitors have to be chosen after the test. Typically, for high frequency capacitor such as high quality POSCAP especially ceramic capacitor, 20% to 100% (for ceramic) more capacitors have to be chosen since the ESR of capacitors is so low that the PCB parasitic can affect the results tremendously. More capacitors have to be selected to compensate these parasitic parameters.

### Compensator Design

Due to the double pole generated by LC filter of the power stage, the power system has 180° phase shift, and therefore, is unstable by itself. In order to achieve accurate output voltage and fast transient response, compensator is employed to provide highest possible bandwidth and enough phase margin. Ideally, the Bode plot of the closed loop system has crossover frequency between 1/10 and 1/5 of the switching frequency, phase margin greater than 50° and the gain crossing 0dB with -20dB/decade. Power stage output capacitors usually decide the compensator type. If electrolytic capacitors are chosen as output capacitors, type II compensator can be used to compensate the system, because the zero caused by output capacitor ESR is lower than crossover frequency. Otherwise type III compensator should be chosen.

#### A. Type III compensator design

For low ESR output capacitors, typically such as Sanyo oscap and poscap, the frequency of ESR zero caused by output capacitors is higher than the crossover frequency. In this case, it is necessary to compensate the system with type III compensator. The following figures and equations show how to realize the type III compensator by transconductance amplifier.

$$F_{Z1} = \frac{1}{2 \times \pi \times R_4 \times C_2} \quad \dots(11)$$

$$F_{Z2} = \frac{1}{2 \times \pi \times (R_2 + R_3) \times C_3} \quad \dots(12)$$

$$F_{P1} = \frac{1}{2 \times \pi \times R_3 \times C_3} \quad \dots(13)$$

$$F_{P2} = \frac{1}{2 \times \pi \times R_4 \times \frac{C_1 \times C_2}{C_1 + C_2}} \quad \dots(14)$$

where  $F_{Z1}, F_{Z2}, F_{P1}$  and  $F_{P2}$  are poles and zeros in the compensator. Their locations are shown in figure 4.

The transfer function of type III compensator for transconductance amplifier is given by:

$$\frac{V_e}{V_{OUT}} = \frac{1 - g_m \times Z_f}{1 + g_m \times Z_{in} + Z_{in} / R_1}$$

For the voltage amplifier, the transfer function of compensator is

$$\frac{V_e}{V_{OUT}} = \frac{-Z_f}{Z_{in}}$$

To achieve the same effect as voltage amplifier, the compensator of transconductance amplifier must satisfy this condition:  $R_4 \gg 2/g_m$ . And it would be desirable if  $R_1 || R_2 || R_3 \gg 1/g_m$  can be met at the same time.

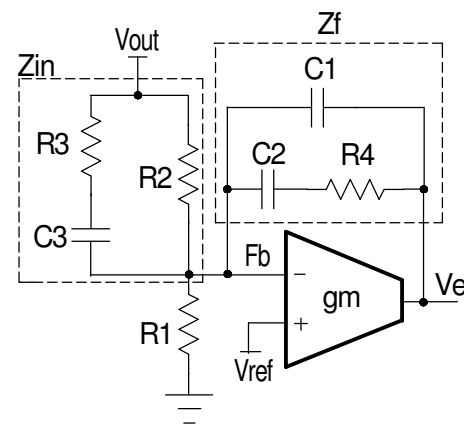

Figure 3 - Type III compensator using transconductance amplifier

**Case 1:**  $F_{LC} < F_O < F_{ESR}$

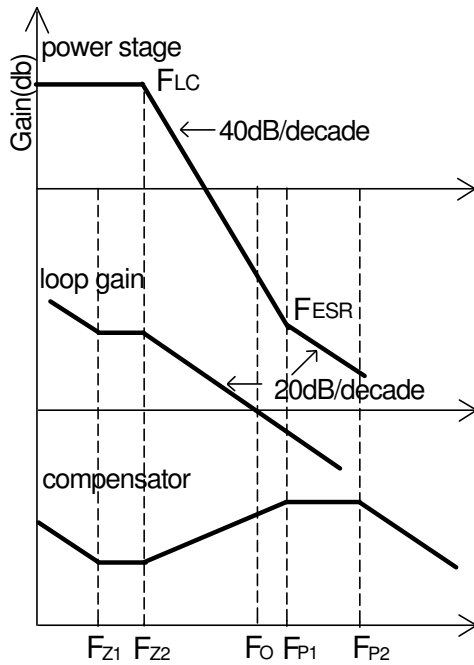

Figure 4 - Bode plot of Type III compensator

Design example for type III compensator are in order. The crossover frequency has to be selected as  $F_{LC} < F_O < F_{ESR}$ , and  $F_O \approx 1/10 \sim 1/5 F_s$ .

1. Calculate the location of LC double pole  $F_{LC}$  and ESR zero  $F_{ESR}$ .

$$F_{LC} = \frac{1}{2 \times \pi \times \sqrt{L_{OUT} \times C_{OUT}}} = \frac{1}{2 \times \pi \times \sqrt{1\mu H \times 440\mu F}} = 7.6\text{kHz}$$

$$F_{ESR} = \frac{1}{2 \times \pi \times ESR \times C_{OUT}} = \frac{1}{2 \times \pi \times 6\text{m}\Omega \times 440\mu F} = 60.3\text{kHz}$$

2. Set  $R_2$  equal to 20k $\Omega$ .

$$R_1 = \frac{R_2 \times V_{REF}}{V_{OUT} - V_{REF}} = \frac{20\text{k}\Omega \times 0.8\text{V}}{1.8\text{V} - 0.8\text{V}} = 16\text{k}\Omega$$

Choose  $R_1 = 16\text{k}\Omega$ .

3. Set zero  $F_{Z2} = F_{LC}$  and  $F_{P1} = F_{ESR}$ .

4. Calculate  $R_4$  and  $C_3$  with the crossover frequency at 1/10~ 1/5 of the switching frequency. Set  $F_O = 50\text{kHz}$ .

$$C_3 = \frac{1}{2 \times \pi \times R_2} \times \left( \frac{1}{F_{Z2}} - \frac{1}{F_{P1}} \right) = \frac{1}{2 \times \pi \times 20\text{k}\Omega} \times \left( \frac{1}{7.6\text{kHz}} - \frac{1}{60.3\text{kHz}} \right) = 916\text{pF}$$

$$R_4 = \frac{V_{OSC}}{V_{in}} \times \frac{2 \times \pi \times F_O \times L}{C_3} \times C_{out} = \frac{1.5\text{V}}{12\text{V}} \times \frac{2 \times \pi \times 50\text{kHz} \times 1\mu H}{1\text{nF}} \times 440\mu F = 17.2\text{k}\Omega$$

Choose  $C_3 = 1\text{nF}$ ,  $R_4 = 17.4\text{k}\Omega$ .

5. Calculate  $C_2$  with zero  $F_{Z1}$  at 75% of the LC double pole by equation (11).

$$C_2 = \frac{1}{2 \times \pi \times F_{Z1} \times R_4} = \frac{1}{2 \times \pi \times 0.75 \times 7.6\text{kHz} \times 17.4\text{k}\Omega} = 1.6\text{nF}$$

Choose  $C_2 = 1.5\text{nF}$ .

6. Calculate  $C_1$  by equation (14) with pole  $F_{P2}$  at half the switching frequency.

$$C_1 = \frac{1}{2 \times \pi \times R_4 \times F_{P2}} = \frac{1}{2 \times \pi \times 17.4\text{k}\Omega \times 300\text{kHz}} = 30\text{pF}$$

Choose  $C_1 = 33\text{pF}$ .

7. Calculate  $R_3$  by equation (13).

$$R_3 = \frac{1}{2 \times \pi \times F_{P1} \times C_3} = \frac{1}{2 \times \pi \times 60.3\text{kHz} \times 1\text{nF}} = 2.64\text{k}\Omega$$

Choose  $R_3 = 2.61\text{k}\Omega$ .

Case 2:  $F_{LC} < F_{ESR} < F_O$

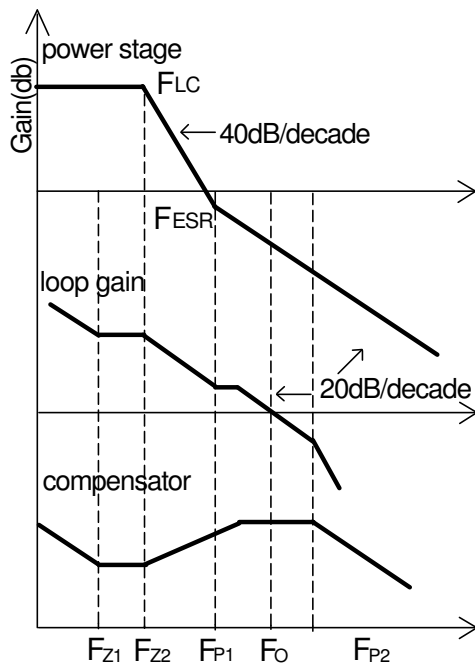

Figure 5 - Bode plot of Type III compensator  
( $F_{LC} < F_{ESR} < F_O$ )

If electrolytic capacitors are used as output capacitors, typical design example of type III compensator in which the crossover frequency is selected as  $F_{LC} < F_{ESR} < F_O$  and  $F_O \leq 1/10 \sim 1/5 F_s$  is shown as the following steps. Here two SANYO MV-WG1500 with 13 mΩ is chosen as output capacitor.

1. Calculate the location of LC double pole  $F_{LC}$  and ESR zero  $F_{ESR}$ :

$$F_{LC} = \frac{1}{2 \times \pi \times \sqrt{L_{OUT} \times C_{OUT}}}$$

$$= \frac{1}{2 \times \pi \times \sqrt{1 \mu\text{H} \times 3000 \mu\text{F}}}$$

$$= 2.9 \text{ kHz}$$

$$F_{ESR} = \frac{1}{2 \times \pi \times \text{ESR} \times C_{OUT}}$$

$$= \frac{1}{2 \times \pi \times 6.5 \text{ m}\Omega \times 3000 \mu\text{F}}$$

$$= 8.2 \text{ kHz}$$

2. Set  $R_2$  equal to 10kΩ.

$$R_1 = \frac{R_2 \times V_{REF}}{V_{OUT} - V_{REF}} = \frac{10 \text{ k}\Omega \times 0.8 \text{ V}}{1.8 \text{ V} - 0.8 \text{ V}} = 8 \text{ k}\Omega$$

Choose  $R_1 = 8 \text{ k}\Omega$ .

3. Set zero  $F_{Z2} = F_{LC}$  and  $F_{P1} = F_{ESR}$ .

4. Calculate  $C_3$ .

$$C_3 = \frac{1}{2 \times \pi \times R_2} \times \left( \frac{1}{F_{Z2}} - \frac{1}{F_{P1}} \right)$$

$$= \frac{1}{2 \times \pi \times 10 \text{ k}\Omega} \times \left( \frac{1}{2.9 \text{ kHz}} - \frac{1}{8.2 \text{ kHz}} \right)$$

$$= 3.5 \text{ nF}$$

Choose  $C_3 = 3.3 \text{ nF}$ .

5. Calculate  $R_3$ .

$$R_3 = \frac{1}{2 \times \pi \times F_{P1} \times C_3}$$

$$= \frac{1}{2 \times \pi \times 8.2 \text{ kHz} \times 3.3 \text{ nF}}$$

$$= 5.9 \text{ k}\Omega$$

Choose  $R_3 = 5.9 \text{ k}\Omega$ .

6. Calculate  $R_4$  with  $F_O = 60 \text{ kHz}$ .

$$R_4 = \frac{V_{OSC}}{V_{in}} \times \frac{2 \times \pi \times F_O \times L}{\text{ESR}} \times \frac{R_2 \times R_3}{R_2 + R_3}$$

$$= \frac{1.5 \text{ V}}{12 \text{ V}} \times \frac{2 \times \pi \times 60 \text{ kHz} \times 1 \mu\text{H}}{6.5 \text{ m}\Omega} \times \frac{10 \text{ k}\Omega \times 5.9 \text{ k}\Omega}{10 \text{ k}\Omega + 5.9 \text{ k}\Omega}$$

$$= 26.9 \text{ k}\Omega$$

Choose  $R_4 = 26.7 \text{ k}\Omega$ .

5. Calculate  $C_2$  with zero  $F_{Z1}$  at 75% of the LC double pole by equation (11).

$$C_2 = \frac{1}{2 \times \pi \times F_{Z1} \times R_4}$$

$$= \frac{1}{2 \times \pi \times 0.75 \times 2.9 \text{ kHz} \times 26.7 \text{ k}\Omega}$$

$$= 2 \text{ nF}$$

Choose  $C_2 = 2.2 \text{ nF}$ .

6. Calculate  $C_1$  by equation (14) with pole  $F_{P2}$  at half the switching frequency.

$$C_1 = \frac{1}{2 \times \pi \times R_4 \times F_{P2}}$$

$$= \frac{1}{2 \times \pi \times 26.7 \text{ k}\Omega \times 300 \text{ kHz}}$$

$$= 20 \text{ pF}$$

Choose  $C_1 = 22 \text{ pF}$ .

### B. Type II compensator design

If the electrolytic capacitors are chosen as power stage output capacitors, usually the Type II compensator can be used to compensate the system.

Type II compensator can be realized by simple RC circuit without feedback as shown in figure 7.  $R_3$  and  $C_1$  introduce a zero to cancel the double pole effect.  $C_2$  introduces a pole to suppress the switching noise. The following equations show the compensator pole zero location and constant gain.

$$\text{Gain} = g_m \times \frac{R_1}{R_1 + R_2} \times R_3 \quad \dots (15)$$

$$F_z = \frac{1}{2 \times \pi \times R_3 \times C_1} \quad \dots (16)$$

$$F_p \approx \frac{1}{2 \times \pi \times R_3 \times C_2} \quad \dots (17)$$

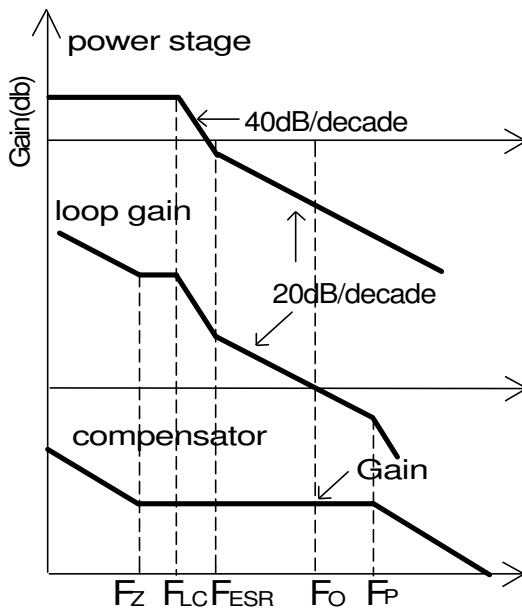

Figure 6 - Bode plot of Type II compensator

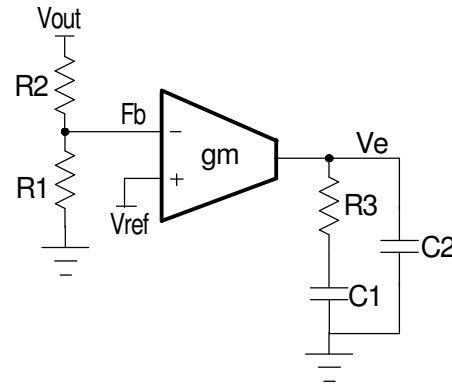

Figure 7 - Type II compensator with transconductance amplifier

For this type of compensator,  $F_o$  has to satisfy  $F_{LC} < F_{ESR} \ll F_o \leq 1/10 \sim 1/5 F_s$ .

The following is parameters for type II compensator design. Input voltage is 12V, output voltage is 1.8V, output inductor is 1uH, output capacitors are two 1500uF with 13mΩ electrolytic capacitors.

1. Calculate the location of LC double pole  $F_{LC}$  and ESR zero  $F_{ESR}$ .

$$F_{LC} = \frac{1}{2 \times \pi \times \sqrt{L_{OUT} \times C_{OUT}}} = \frac{1}{2 \times \pi \times \sqrt{1 \mu H \times 3000 \mu F}} = 2.9 \text{ kHz}$$

$$F_{ESR} = \frac{1}{2 \times \pi \times \text{ESR} \times C_{OUT}} = \frac{1}{2 \times \pi \times 6.5 \text{ m}\Omega \times 3000 \mu F} = 8.2 \text{ kHz}$$

2. Set  $R_2$  equal to 1kΩ.

$$R_1 = \frac{R_2 \times V_{REF}}{V_{OUT} - V_{REF}} = \frac{1 \text{ k}\Omega \times 0.8 \text{ V}}{1.8 \text{ V} - 0.8 \text{ V}} = 800 \Omega$$

Choose  $R_1 = 806 \Omega$ .

3. Set crossover frequency at 1/10 ~ 1/5 of the switching frequency, here  $F_o = 60 \text{ kHz}$ .

4. Calculate  $R_3$  value by the following equation.

4. Calculate  $R_3$  value by the following equation.

$$\begin{aligned}
 R_3 &= \frac{V_{OSC}}{V_{in}} \times \frac{2 \times \pi \times F_o \times L}{R_{ESR}} \times \frac{1}{g_m} \times \frac{V_{OUT}}{V_{REF}} \\
 &= \frac{1.5V}{12V} \times \frac{2 \times \pi \times 60kHz \times 1\mu H}{6.5m\Omega} \times \frac{1}{2.0mA/V} \\
 &\quad \times \frac{1.8V}{0.8V} \\
 &= 8.15k\Omega
 \end{aligned}$$

Choose  $R_3 = 8.2k\Omega$ .

5. Calculate  $C_1$  by setting compensator zero  $F_z$  at 75% of the LC double pole.

$$\begin{aligned}
 C_1 &= \frac{1}{2 \times \pi \times R_3 \times F_z} \\
 &= \frac{1}{2 \times \pi \times 8.2k\Omega \times 0.75 \times 2.9kHz} \\
 &= 8.9nF
 \end{aligned}$$

Choose  $C_1 = 8.2nF$ .

6. Calculate  $C_2$  by setting compensator pole  $F_p$  at half the switching frequency.

$$\begin{aligned}
 C_2 &= \frac{1}{\pi \times R_3 \times F_s} \\
 &= \frac{1}{\pi \times 8.2k\Omega \times 300kHz} \\
 &= 129pF
 \end{aligned}$$

Choose  $C_2 = 120pF$ .

## Output Voltage Calculation

Output voltage is set by reference voltage and external voltage divider. The reference voltage is fixed at 0.8V. The divider consists of two ratioed resistors so that the output voltage applied at the Fb pin is 0.8V when the output voltage is at the desired value. The following equation and picture show the relationship between  $V_{OUT}$ ,  $V_{REF}$  and voltage divider.

$$R_1 = \frac{R_2 \times V_{REF}}{V_{OUT} - V_{REF}} \quad \dots(18)$$

where  $R_2$  is part of the compensator, and the value of  $R_1$  value can be set by voltage divider.

See compensator design for  $R_1$  and  $R_2$  selection.

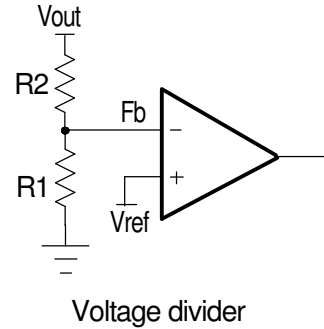

Figure 8 - Voltage divider

## Input Capacitor Selection

Input capacitors are usually a mix of high frequency ceramic capacitors and bulk capacitors. Ceramic capacitors bypass the high frequency noise, and bulk capacitors supply switching current to the MOSFETs. Usually 1uF ceramic capacitor is chosen to decouple the high frequency noise. The bulk input capacitors are decided by voltage rating and RMS current rating. The RMS current in the input capacitors can be calculated as:

$$\begin{aligned}
 I_{RMS} &= I_{OUT} \times \sqrt{D} \times \sqrt{1-D} \\
 D &= \frac{V_{OUT}}{V_{IN}}
 \end{aligned} \quad \dots(19)$$

$V_{IN} = 12V$ ,  $V_{OUT} = 1.8V$ ,  $I_{OUT} = 9A$ , using equation (19), the result of input RMS current is 3.2A.

For higher efficiency, low ESR capacitors are recommended. One Sanyo OS-CON 16SP180M 16V 180uF 20mΩ with 3.4A RMS rating is chosen as input bulk capacitors.

## Power MOSFETs Selection

The power stage requires two N-Channel power MOSFETs. The selection of MOSFETs is based on maximum drain source voltage, gate source voltage, maximum current rating, MOSFET on resistance and power dissipation. The main consideration is the power loss contribution of MOSFETs to the overall converter efficiency. In this design example, two IRFR3709Z are used. They have the following parameters:  $V_{DS} = 30V$ ,  $R_{DS(ON)} = 6.5m\Omega$ ,  $Q_{GATE} = 17nC$ .

There are two factors causing the MOSFET power loss: conduction loss, switching loss.

Conduction loss is simply defined as:

$$\begin{aligned}
 P_{HCON} &= I_{OUT}^2 \times D \times R_{DS(ON)} \times K \\
 P_{LCON} &= I_{OUT}^2 \times (1-D) \times R_{DS(ON)} \times K \\
 P_{TOTAL} &= P_{HCON} + P_{LCON}
 \end{aligned}
 \quad \dots(20)$$

where the  $R_{DS(ON)}$  will increase as MOSFET junction temperature increases,  $K$  is  $R_{DS(ON)}$  temperature dependency. As a result,  $R_{DS(ON)}$  should be selected for the worst case, in which  $K$  approximately equals to 1.4 at 125°C according to IRFR3709Z datasheet. Conduction loss should not exceed package rating or overall system thermal budget.

Switching loss is mainly caused by crossover conduction at the switching transition. The total switching loss can be approximated.

$$P_{SW} = \frac{1}{2} \times V_{IN} \times I_{OUT} \times T_{SW} \times F_S \quad \dots(21)$$

where  $I_{OUT}$  is output current,  $T_{SW}$  is the sum of  $T_R$  and  $T_F$  which can be found in mosfet datasheet, and  $F_S$  is switching frequency. Switching loss  $P_{SW}$  is frequency dependent.

Also MOSFET gate driver loss should be considered when choosing the proper power MOSFET. MOSFET gate driver loss is the loss generated by discharging the gate capacitor and is dissipated in driver circuits. It is proportional to frequency and is defined as:

$$P_{gate} = (Q_{HGATE} \times V_{HGS} + Q_{LGATE} \times V_{LGS}) \times F_S \quad \dots(22)$$

where  $Q_{HGATE}$  is the high side MOSFETs gate charge,  $Q_{LGATE}$  is the low side MOSFETs gate charge,  $V_{HGS}$  is the high side gate source voltage, and  $V_{LGS}$  is the low side gate source voltage.

This power dissipation should not exceed maximum power dissipation of the driver device.

## Soft Start and Enable

NX2116 has digital soft start for switching controller and has one enable pin for this start up. When the Power Ready (POR) signal is high and the voltage at enable pin is above 1.25V the internal digital counter starts to operate and the voltage at positive input of Error amplifier starts to increase, the feedback network will force the output voltage follows the reference and starts the output slowly. After 2048 cycles, the soft start is complete and the output voltage is regulated to the de-

sired voltage decided by the feedback resistor divider.

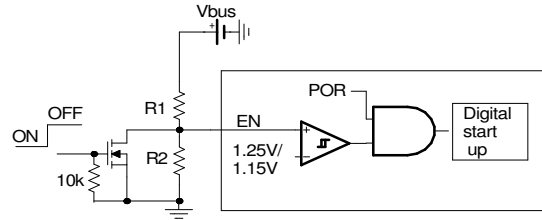

Figure 9 - Enable and Shut down the NX2116 with Enable pin.

The start up of NX2116 can be programmed through resistor divider at Enable pin. For example, if the input bus voltage is 12V and we want NX2116 starts when  $V_{bus}$  is above 9V. We can select using the following equation.

$$R_1 = \frac{(9V - 1.25V) \times R_2}{1.25V}$$

The NX2116 can be turned off by pulling down the Enable pin by extra signal MOSFET as shown in the above Figure. When Enable pin is below 1.25V, the digital soft start is reset to zero. In addition, all the high side and low side driver is off and no negative spike will be generated during the turn off.

## Over Current Protection

Over current protection is achieved by sensing current through the low side MOSFET. An internal current source of 40uA flows through an external resistor connected from OCP pin to SW node sets the over current protection threshold. When synchronous FET is on, the voltage at node SW is given as

$$V_{SW} = -I_L \times R_{DS(ON)}$$

The voltage at pin OCP is given as

$$I_{OCP} \times R_{OCP} + V_{SW}$$

When the voltage is below zero, the over current occurs as shown in figure 10.

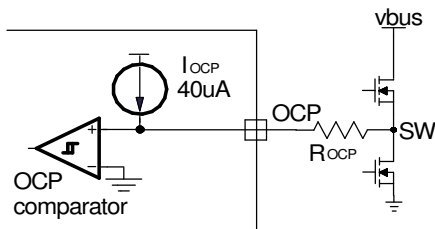

Figure 10 - Over current protection

The over current limit can be set by the following equation

$$I_{SET} = \frac{I_{OCP} \times R_{OCP}}{K \times R_{DSON}}$$

If MOSFET  $R_{DSON}=6.5m\Omega$ , the worst case thermal consideration  $K=1.5$  and the current limit is set at 15A, then

$$R_{OCP} = \frac{I_{SET} \times K \times R_{DSON}}{I_{OCP}} = \frac{15A \times 1.5 \times 6.5m\Omega}{40\mu A} = 3.656k\Omega$$

Choose  $R_{OCP}=3.7k\Omega$

## Layout Considerations

The layout is very important when designing high frequency switching converters. Layout will affect noise pickup and can cause a good design to perform with less than expected results.

Start to place the power components, make all the connection in the top layer with wide, copper filled areas. The inductor, output capacitor and the MOSFET should be close to each other as possible. This helps to reduce the EMI radiated by the power traces due to the high switching currents through them. Place input capacitor directly to the drain of the high-side MOSFET, to reduce the ESR replace the single input capacitor with two parallel units. The feedback part of the system should be kept away from the inductor and other noise sources, and be placed close to the IC. In multilayer PCB use one layer as power ground plane and have a control circuit ground (analog ground), to which all signals are referenced.

The goal is to localize the high current path to a separate loop that does not interfere with the more sensitive analog control function. These two grounds must be connected together on the PC board layout at a single point.