

**DESCRIPTION**

The UM4300 and UM7300 series combine a diode chip of extremely thick intrinsic region with a low thermal resistance construction. This results in diodes uniquely applicable to very low distortion linear attenuators and specialized functions. The UM4300 series, with large cross-sectional chip area offers the highest power capability, of the two series. The UM7300 series offers lower capacitance. Both diode series are intended for use in linear attenuators operating from HF to beyond 1 GHz. Low distortion is a result of transit time frequencies below 5 MHz. Operated as RF switches, either diode series can be operated at low dc reverse bias voltages, to hold off much higher RF voltage levels.

**KEY FEATURES**

- Extremely low distortion performance
- Useful frequency range extends below 500 kHz
- Power dissipation to 20 W (UM4300)
- Capacitance as low as 0.7 pF (UM7300)
- Voltage ratings to 1000V
- Non cavity design
- Thermally matched
- Isolated stud package available

**ABSOLUTE MAXIMUM RATINGS AT 25° C  
(UNLESS OTHERWISE SPECIFIED)**

Pkg	Condition	UM4300		UM7300	
		P <sub>D</sub> (W)	θ (°C/W)	P <sub>D</sub> (W)	θ (°C/W)
A	25 °C Pin Temperature	20	7.5	7.5	20
B & E	½ in. total length to 25 °C Contact Free Air	10 2.5	15	4	37.5
C	25 °C Stud Temperature	20	7.5	7.5	20
D	25 °C Stud Temperature	15	10	6	25
SM	25 °C End Cap Temperature	15	20	5.5	18
ALL	1 us pulse (Single)	500 kW		100 kW	

**APPLICATIONS / BENEFITS**

- RF Switching
- RF Attenuators
- Pick and Place compatible
- Surface Mount Versions
- <sup>1</sup>RoHS compliant packaging available: use UMX4301SM, etc

**VOLTAGE RATINGS**

Reverse Voltage @ 10uA	Part Number	
100	UM4301	UM7301
200	UM4302	UM7302
600	UM4306	UM7306
1000	UM4310	UM7310

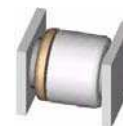
**IMPORTANT:**

For the most current data consult *MICROSEMI's* website:  
[www.MICROSEMI.com](http://www.MICROSEMI.com)

1 - RoHS compliant versions of the UM4300 and UM7300 are available. Specify UMX4300 or UMX7300 for RoHS version. Consult factory for details.

**ELECTRICAL CHARACTERISTICS (@ 25°C unless otherwise specified)**

Parameter	Symbol	Conditions	UM4300	UM7300	Units
Reverse Current (Max)	$I_R$	At rated voltage	10	10	$\mu A$
Series Resistance(Max)	$R_S$	$I_f = 100 \text{ mA}$ , $F = 100 \text{ MHz}$	1.5	3.0	Ohms
Series Resistance(Min)	$R_S$	$I_f = 10 \text{ }\mu A$ , $F = 100 \text{ MHz}$	1000	3000	Ohms
Capacitance (Max)	$C_T$	$V_R = 100 \text{ V}$ , $F = 1 \text{ MHz}$	2.2	0.7	pF
Parallel Resistance(Min)	$R_P$	$V_R = 100 \text{ V}$ , $F = 100 \text{ MHz}$	200k	150k	Ohms
Carrier Lifetime(Min)	$\tau$	$I_F = 10 \text{ mA}$	6.0	4.0	us
I-Region Width (Min)	W	--	250	250	$\mu m$

**TYPICAL  $R_S$  VS  $I_F$**

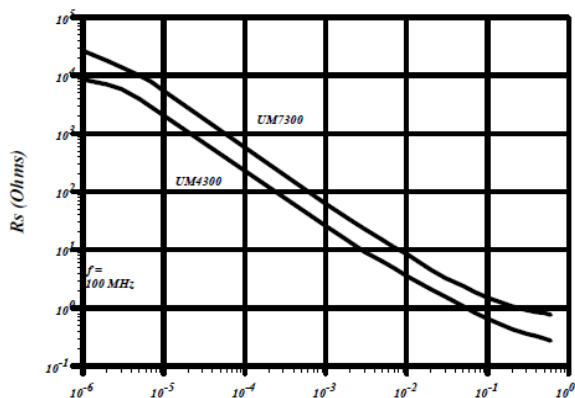

**TYPICAL  $I_F$  VS  $V_f$**

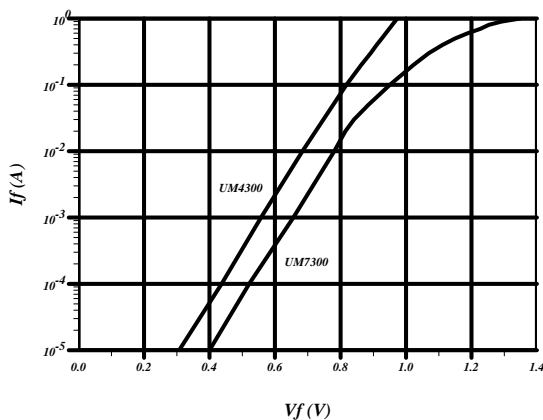

**$R_P$  VS  $V_R$  (UM4300)**

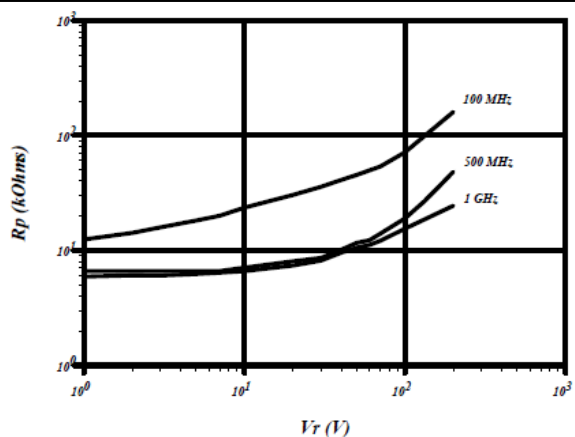

**$R_P$  VS  $V_R$  (UM4300)**

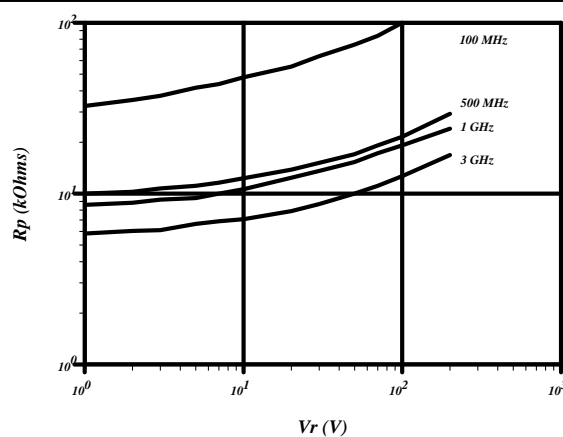

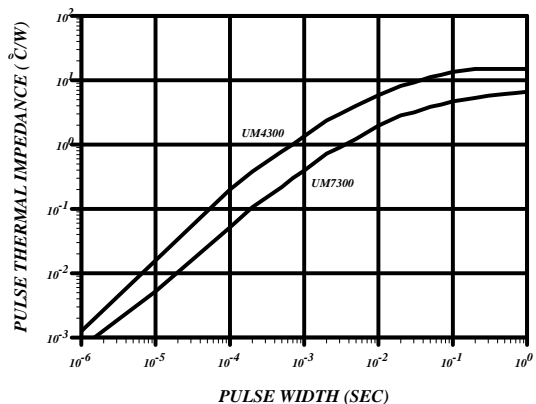
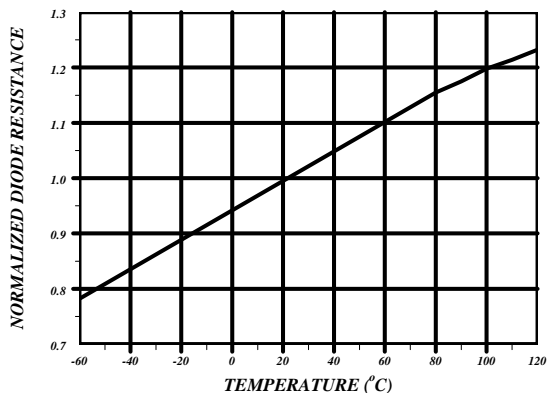
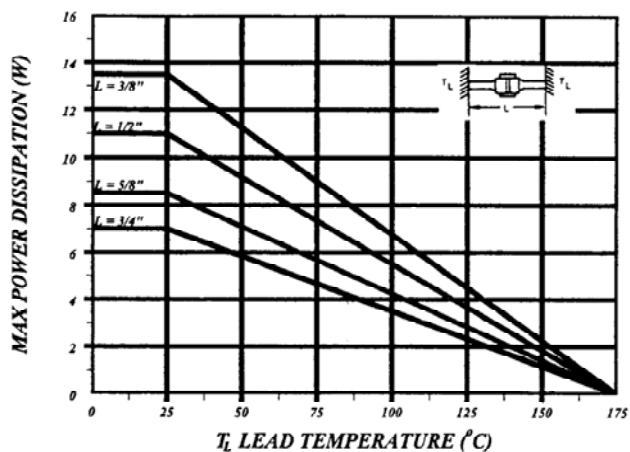
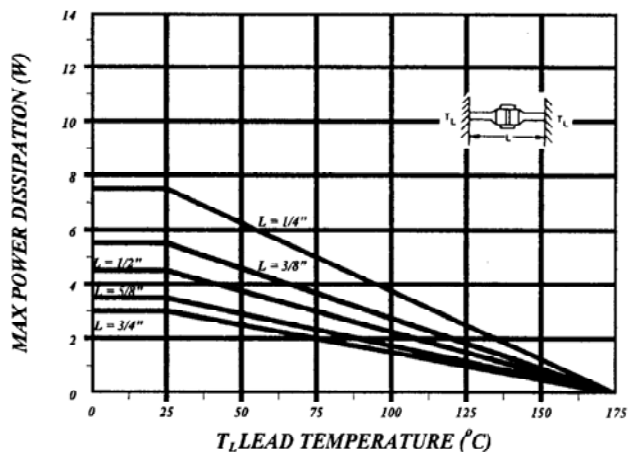
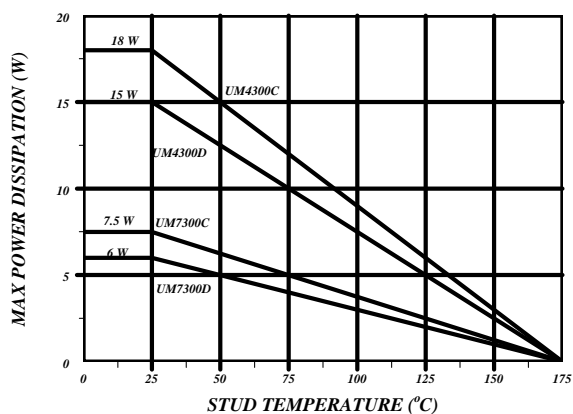
**THERMAL IMP. VS PULSE WIDTH**

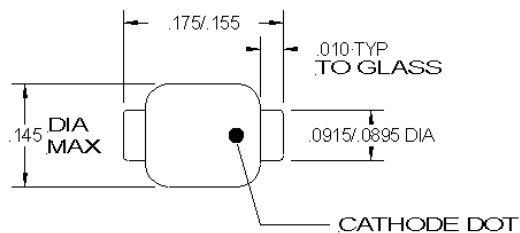
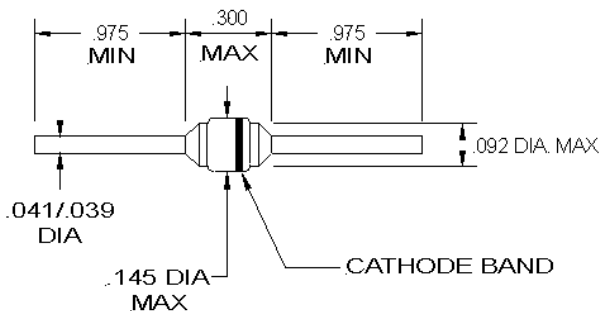
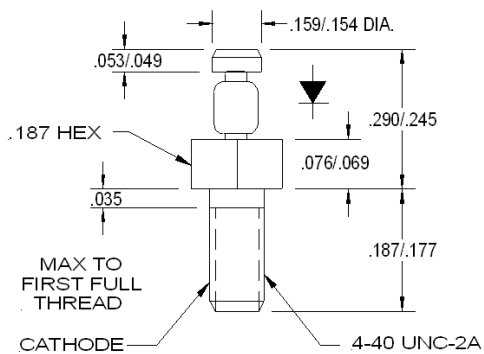
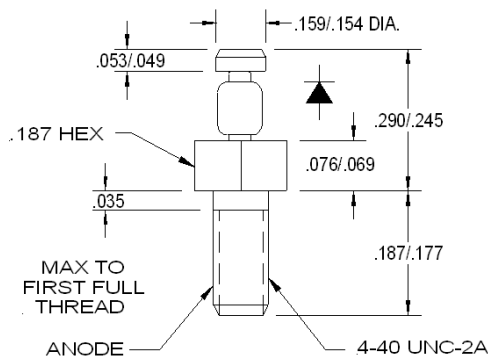
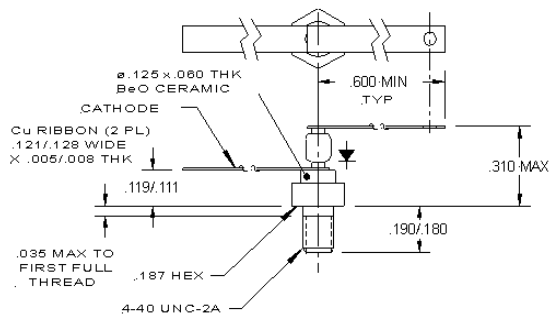
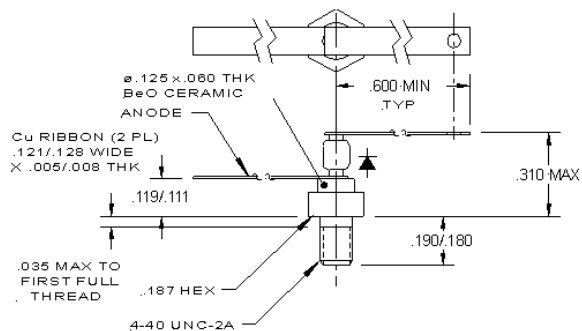
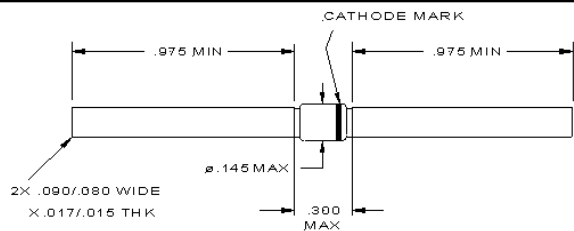
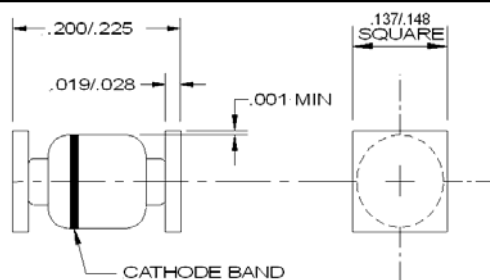
**NORMALIZED RS VS TEMP.**

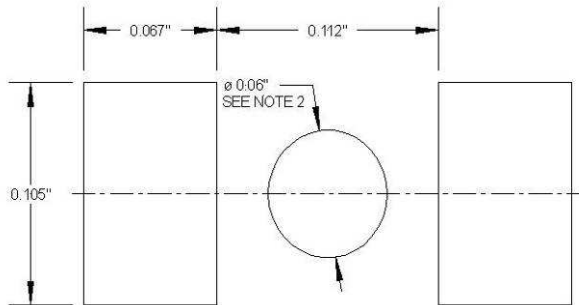
**POWER DISS. VS LEAD TEMP. (UM4300)**

**POWER DISS. VS LEAD TEMP. (UM7300)**

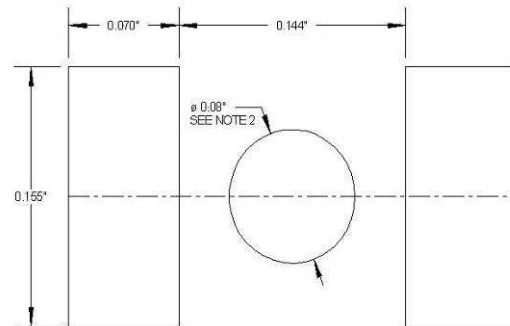
**POWER RATINGS (STUD PKG)**

**PACKAGE STYLES**
**STYLE 'A'**

**STYLE 'B'**

**STYLE 'C'**

**STYLE 'CR'**

**STYLE 'D'**

**STYLE 'DR'**

**STYLE 'E'**

**STYLE 'SM'**

**UM7300 STYLE 'SM' FOOTPRINT**

UM7300 Style SM, A Size Footprint

**UM4300 STYLE 'SM' FOOTPRINT**

UM4300 Style SM, B Size Footprint

1. These dimensions will match the terminals and provide for additional solder fillets at the outboard ends at least as wide as the terminals themselves, assuming accuracy of placement within 0.005"
2. If the mounting method chosen requires use of an adhesive separate from the solder compound, a round (or square) spot of cement as shown should be centrally located.