

## Single switch NPT IGBT Power Module

$V_{CES} = 600V$   
 $I_C = 660A @ T_c = 80^\circ C$

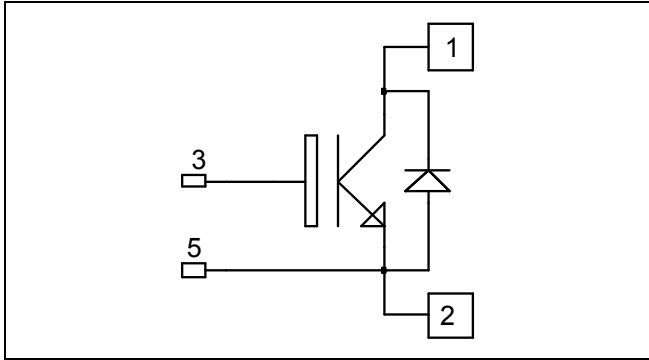

### Application

- Welding converters
- Switched Mode Power Supplies
- Uninterruptible Power Supplies
- Motor control

### Features

- Non Punch Through (NPT) IGBT
  - Low voltage drop
  - Low tail current
  - Switching frequency up to 50 kHz
  - Soft recovery parallel diodes
  - Low diode VF
  - Low leakage current
  - RBSOA and SCSOA rated
- Kelvin emitter for easy drive
- M6 connectors for power
- M4 connectors for signal
- High level of integration

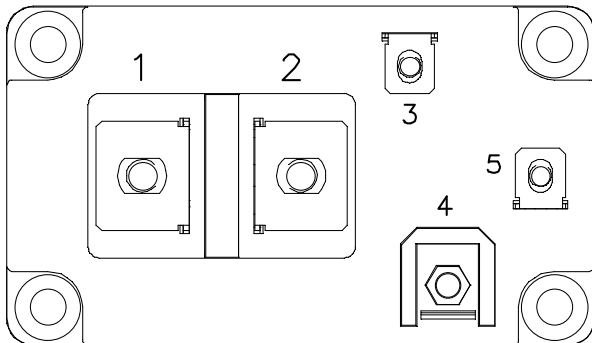

### Benefits

- Outstanding performance at high frequency operation
- Stable temperature behavior
- Very rugged
- Direct mounting to heatsink (isolated package)
- Low junction to case thermal resistance
- Easy paralleling due to positive  $T_C$  of  $V_{CESat}$
- RoHS Compliant

### Absolute maximum ratings

Symbol	Parameter	Max ratings	Unit
$V_{CES}$	Collector - Emitter Breakdown Voltage	600	V
$I_C$	Continuous Collector Current	$T_C = 25^\circ C$	860
		$T_C = 80^\circ C$	660
$I_{CM}$	Pulsed Collector Current	$T_C = 25^\circ C$	1320
$V_{GE}$	Gate - Emitter Voltage	$\pm 20$	V
$P_D$	Maximum Power Dissipation	$T_C = 25^\circ C$	2800
RBSOA	Reverse Bias Safe Operating Area	$T_j = 125^\circ C$	1600A@520V

**CAUTION:** These Devices are sensitive to Electrostatic Discharge. Proper Handling Procedures Should Be Followed. See application note APT0502 on [www.microsemi.com](http://www.microsemi.com)

All ratings @  $T_j = 25^\circ\text{C}$  unless otherwise specified

**Electrical Characteristics**

Symbol	Characteristic	Test Conditions	Min	Typ	Max	Unit	
$I_{CES}$	Zero Gate Voltage Collector Current	$V_{GE} = 0V$ $V_{CE} = 600V$	$T_j = 25^\circ\text{C}$			500	$\mu\text{A}$
			$T_j = 125^\circ\text{C}$			1	$\text{mA}$
$V_{CE(sat)}$	Collector Emitter saturation Voltage	$V_{GE} = 15V$ $I_C = 800A$	$T_j = 25^\circ\text{C}$	1.95	2.45	V	
			$T_j = 125^\circ\text{C}$	2.2			
$V_{GE(th)}$	Gate Threshold Voltage	$V_{GE} = V_{CE}, I_C = 16\text{mA}$	4.5	5.5	6.5	V	
$I_{GES}$	Gate – Emitter Leakage Current	$V_{GE} = 20V, V_{CE} = 0V$			2400	$\text{nA}$	

**Dynamic Characteristics**

Symbol	Characteristic	Test Conditions	Min	Typ	Max	Unit
$C_{ies}$	Input Capacitance	$V_{GE} = 0V, V_{CE} = 25V$ $f = 1\text{MHz}$		36		$\text{nF}$
$C_{res}$	Reverse Transfer Capacitance			3.2		
$Q_G$	Gate charge	$V_{GE} = 15V, I_C = 800A$ $V_{CE} = 300V$		2		$\mu\text{C}$
$T_{d(on)}$	Turn-on Delay Time	Inductive Switching ( $25^\circ\text{C}$ ) $V_{GE} = \pm 15V$ $V_{Bus} = 300V$ $I_C = 800A$ $R_G = 16\Omega$		150		ns
$T_r$	Rise Time			72		
$T_{d(off)}$	Turn-off Delay Time			530		
$T_f$	Fall Time			40		
$T_{d(on)}$	Turn-on Delay Time	Inductive Switching ( $125^\circ\text{C}$ ) $V_{GE} = \pm 15V$ $V_{Bus} = 300V$ $I_C = 800A$ $R_G = 16\Omega$		160		ns
$T_r$	Rise Time			75		
$T_{d(off)}$	Turn-off Delay Time			550		
$T_f$	Fall Time			50		
$E_{on}$	Turn on Energy	$V_{GE} = \pm 15V$ $V_{Bus} = 300V$ $I_C = 800A$	$T_j = 125^\circ\text{C}$	36		$\text{mJ}$
$E_{off}$	Turn off Energy	$R_G = 16\Omega$	$T_j = 125^\circ\text{C}$	33		$\text{mJ}$
$I_{sc}$	Short Circuit data	$V_{GE} \leq 15V; V_{Bus} = 360V$ $t_p \leq 10\mu\text{s}; T_j = 125^\circ\text{C}$		3600		A

**Reverse diode ratings and characteristics**

Symbol	Characteristic	Test Conditions	Min	Typ	Max	Unit
$V_{RRM}$	Maximum Peak Repetitive Reverse Voltage		600			V
$I_{RRM}$	Maximum Reverse Leakage Current	$V_R = 600V$	$T_j = 25^\circ\text{C}$		750	$\mu\text{A}$
			$T_j = 125^\circ\text{C}$		1000	
$I_F$	DC Forward Current			800		A
$V_F$	Diode Forward Voltage	$I_F = 800A$ $V_{GE} = 0V$	$T_j = 25^\circ\text{C}$	1.25	1.6	V
			$T_j = 125^\circ\text{C}$	1.2		
$t_{rr}$	Reverse Recovery Time	$I_F = 800A$ $V_R = 300V$ $di/dt = 7000A/\mu\text{s}$	$T_j = 25^\circ\text{C}$	150		ns
			$T_j = 125^\circ\text{C}$	250		
$Q_{rr}$	Reverse Recovery Charge	$I_F = 800A$ $V_R = 300V$ $di/dt = 7000A/\mu\text{s}$	$T_j = 25^\circ\text{C}$	57		$\mu\text{C}$
			$T_j = 125^\circ\text{C}$	80		
$E_{rr}$	Reverse Recovery Energy	$I_F = 800A$ $V_R = 300V$ $di/dt = 7000A/\mu\text{s}$	$T_j = 25^\circ\text{C}$	11.6		mJ
			$T_j = 125^\circ\text{C}$	22.8		



## Typical Performance Curve

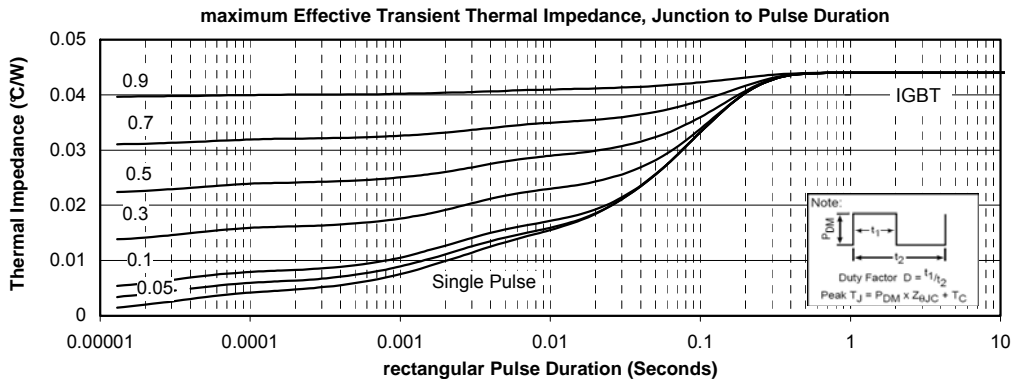
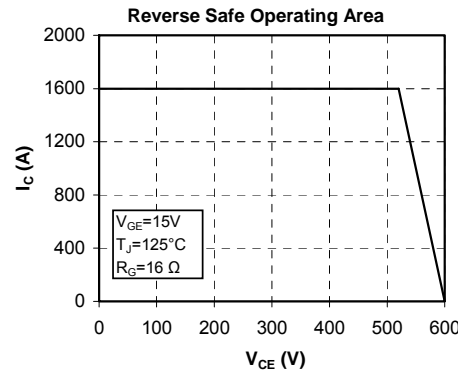
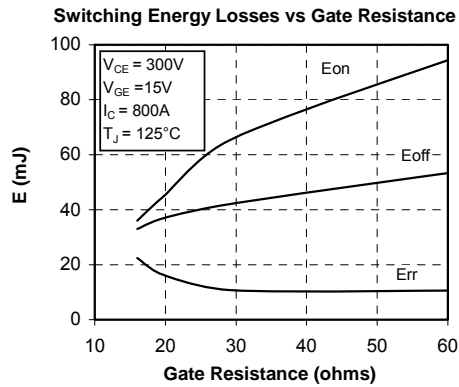
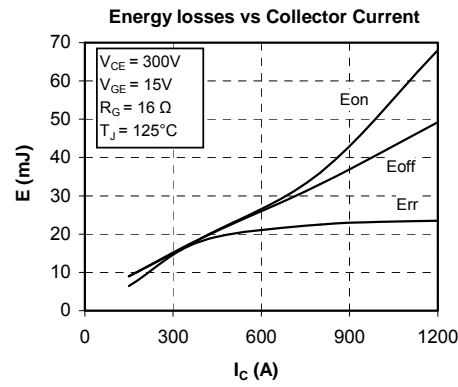
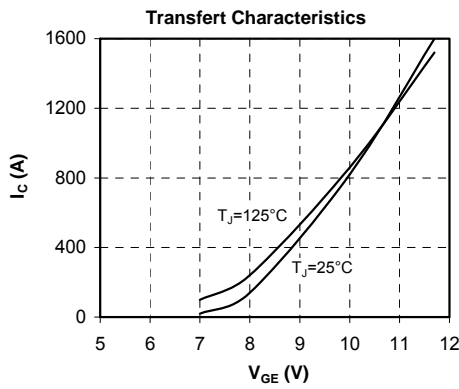
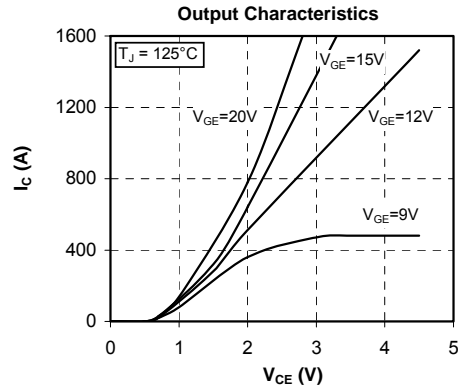
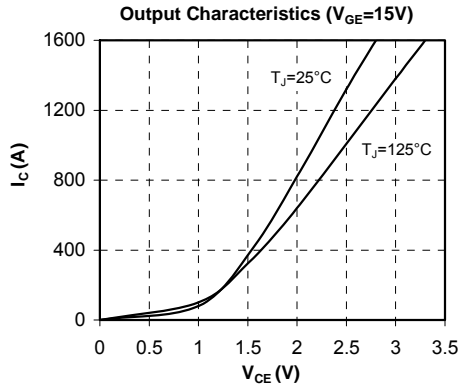

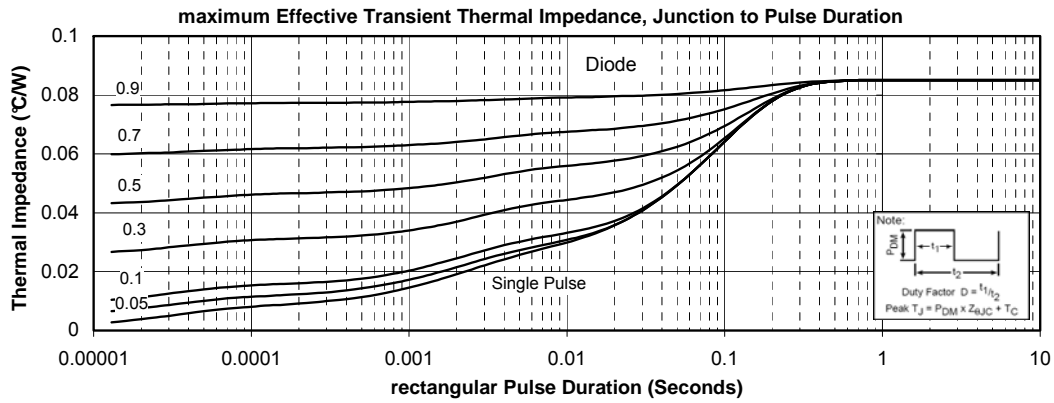
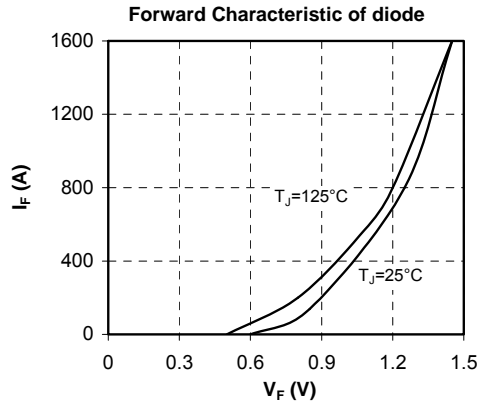
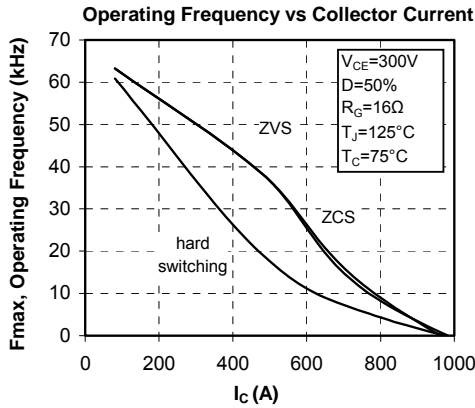

Microsemi reserves the right to change, without notice, the specifications and information contained herein

Microsemi's products are covered by one or more of U.S. patents 4,895,810 5,045,903 5,089,434 5,182,234 5,019,522 5,262,336 6,503,786 5,256,583 4,748,103 5,283,202 5,231,474 5,434,095 5,528,058 6,939,743 7,352,045 5,283,201 5,801,417 5,648,283 7,196,634 6,664,594 7,157,886 6,939,743 7,342,262 and foreign patents. U.S. and Foreign patents pending. All Rights Reserved.