

Silicon Controlled Rectifiers

2N1909 — 2N1916

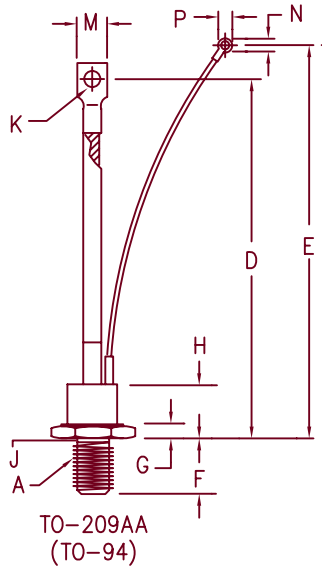

Dim.	Inches		Millimeter		Notes
	Minimum	Maximum	Minimum	Maximum	
A	---	---	---	---	1
B	1.050	1.060	26.67	26.92	across flats
C	---	1.161	---	29.49	
D	5.850	6.144	149.10	156.06	
E	6.850	7.375	173.99	187.33	
F	.797	.827	20.24	21.01	
G	.276	.286	.701	7.26	
H	---	.948	---	24.08	
J	.425	.499	10.80	12.67	2
K	.260	.280	6.60	7.11	Dia.
M	.500	.600	12.70	15.24	
N	.140	.150	3.56	3.81	
P	---	.295	---	7.49	

Note 1: 1/2-20 UNF-3A

Note 2: Full thread within 2 1/2 threads

Microsemi Catalog Number	Forward & Reverse Repetitive Blocking	Reverse Transient Blocking
2N1909	25	25
2N1910	50	50
2N1911	100	100
2N1912	150	150
2N1913	200	200
2N1914	250	250
2N1915	300	300
2N1916	400	400

To specify dv/dt higher than 200V/usec., contact factory.

- High dv/dt-200 V/usec.
- 1600 Amperes surge current
- Low forward on-state voltage
- Package conforming to TO-209AA outline
- Economical for general purpose phase control applications

Electrical Characteristics

Max. RMS on-state current	$I_T(\text{RMS})$ 110 Amps	$T_C = 87^\circ\text{C}$
Max. average on-state cur.	$I_T(\text{AV})$ 70 Amps	$T_C = 87^\circ\text{C}$
Max. peak on-state voltage	V_{TM} 1.6 Volts	$I_{TM} = 220 \text{ A(peak)}$
Max. holding current	I_H 200 mA	
Max. peak one cycle surge current	I_{TSM} 1600 A	$T_C = 87^\circ\text{C}, 60 \text{ Hz}$
Max. I^2t capability for fusing	I^2t 10,624A ² S	$t = 8.3 \text{ ms}$

Thermal and Mechanical Characteristics

Operating junction temp range	T_J	-65°C to 125°C
Storage temperature range	T_{STG}	-65°C to 150°C
Maximum thermal resistance	$R_{\theta JC}$	0.40°C/W Junction to case
Typical thermal resistance (greased)	$R_{\theta CS}$	0.20°C/W Case to sink
Mounting torque		100-130 inch pounds
Weight		3.6 ounces (102.0 grams) typical



6 Lake Street
Lawrence, MA 01841
PH: (978) 620-2600
FAX: (978) 689-0803
www.microsemi.com

04-24-07 Rev. 1

2N1909 – 2N1916

Switching

Critical rate of rise of on-state current (note 1)	di/dt	100A/usec.	$T_J = 125^\circ\text{C}$
Typical delay time (note 1)	t_d	3.0 usec.	
Typical circuit commuted turn-off time (note 2)	t_q	100 usec.	$T_J = 125^\circ\text{C}$

Note 1: $I_{TM} = 50\text{A}$, $V_D = V_{DRM}$, $V_{GT} = 12\text{V}$ open circuit, 20 ohm-0.1 usec. rise time

Note 2: $I_{TM} = 50\text{A}$, $di/dt = 5\text{A/usec.}$, V_R during turn-off interval = 50V min.,
reapplied $dv/dt = 20\text{V/usec.}$, linear to rated V_{DRM} , $V_{GT} = 0\text{V}$

Triggering

Max. gate voltage to trigger	V_{GT}	3.0V	$T_J = 25^\circ\text{C}$
Max. nontriggering gate voltage	V_{GD}	0.25V	$T_J = 125^\circ\text{C}$
Max. gate current to trigger	I_{GT}	100mA	$T_J = 25^\circ\text{C}$
Max. peak gate power	P_{GM}	15W	
Average gate power	$P_{G(AV)}$	3.0W	$t_p = 10 \text{ usec.}$
Max. peak gate current	I_{GM}	4.0A	
Max. peak gate voltage (forward)	V_{GM}	10V	
Max. peak gate voltage (reverse)	V_{GM}	5.0V	

Blocking

Max. leakage current	I_{DRM}, I_{RRM}	10mA	$T_J = 125^\circ\text{C} \ \& \ V_{DRM}, V_{RRM}$
Max. reverse leakage	I_{DRM}, I_{RRM}	100uA	$T_J = 25^\circ\text{C} \ \& \ V_{DRM}, V_{RRM}$
Critical rate of rise of off-state voltage	dv/dt	200V/usec.	$T_J = 125^\circ\text{C}$

2N1909 — 2N1916

Figure 1
Typical Forward On-State Characteristics

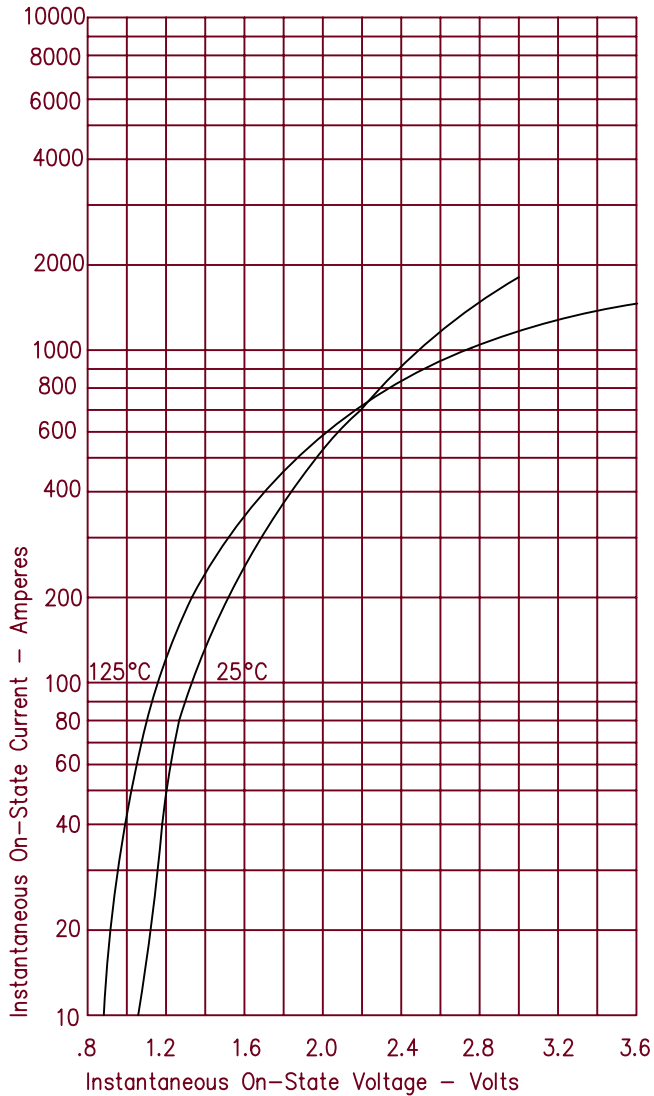

Figure 3
Maximum Power Dissipation

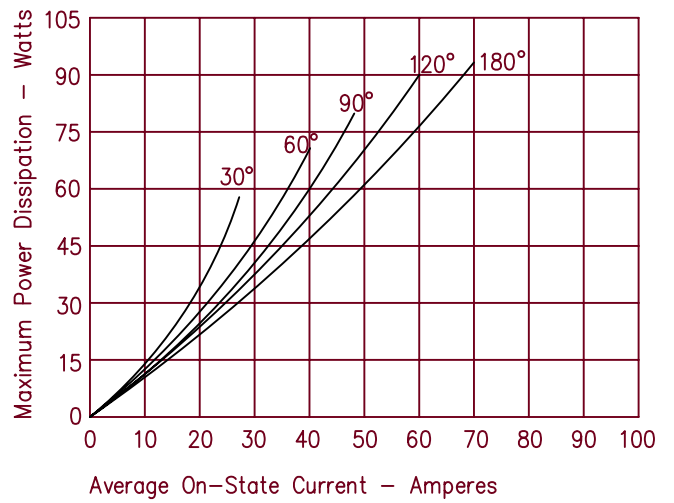

Figure 4
Transient Thermal Impedance

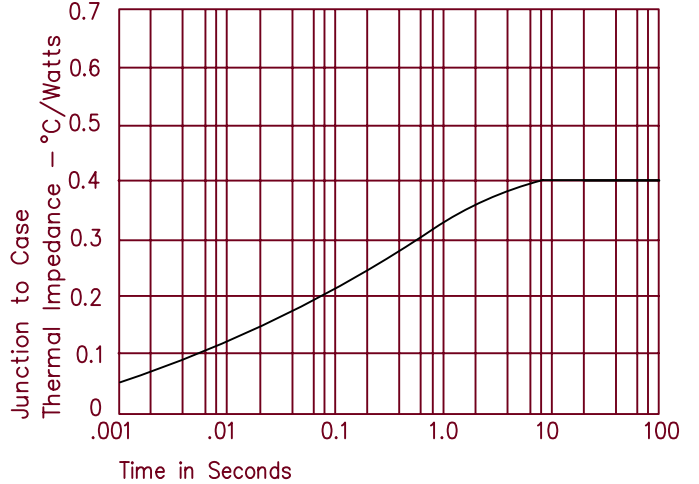

Figure 2
Forward Current Derating

