

DESCRIPTION

The 2EZ3.6D5 thru 2EZ200D5 series of axial-leaded 2.0 watt Zeners provides voltage regulation selections with 5% tolerances from 3.6 to 200 volts in a DO-41 plastic package size. Other Zener voltage tolerances are also available by changing the suffix number to the tolerance desired such as 1 and 2 for tighter tolerances or 10 for wider tolerance. These plastic encapsulated Zeners are also available in various military equivalent screening levels by adding a prefix identifier as also described in the Features section. They may be operated at high maximum dc currents or full power rating with adequate heat. Microsemi also offers numerous other Zener products to meet higher and lower power applications.

APPEARANCE

DO-41 or
DO-204AL
(Plastic)

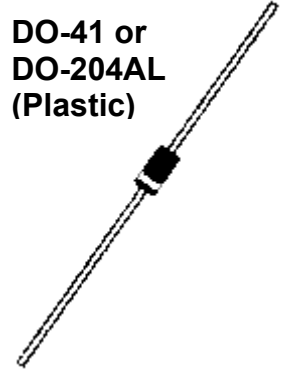

IMPORTANT: For the most current data, consult MICROSEMI's website: <http://www.microsemi.com>

FEATURES

- Zener voltage available 3.6 V to 200 V
- Standard voltage tolerances are plus/minus 5% with a 5 suffix and 10 % with 10 suffix identification
- Tight tolerances available in plus or minus 2% or 1% with 2 or 1 suffix respectively
- Options for screening in accordance with MIL-PRF-19500 for JAN, JANTX, and JANTXV are available by adding MQ, MX, or MV prefixes respectively to part numbers.
- Surface mount equivalents available as SMBJ2EZ3.6D5 to SMBJ2EZ200D5 in the DO-214AA package, or SMBG2EZ3.6D5 to SMBG200D5 in the DO-215AA package
- RoHS compliant devices available by adding "e3" suffix

APPLICATIONS / BENEFITS

- Regulates voltage over a broad operating current and temperature range
- Wide selection from 3.6 to 200 V
- Flexible axial-lead mounting terminals
- Nonsensitive to ESD per MIL-STD-750 Method 1020
- Withstands surge stresses
- High specified maximum current (I_{ZM}) when adequately heat sunk

MAXIMUM RATINGS

- Power dissipation at 25°C: 3.0 watts (also see derating in Figure 1).
- Operating and Storage temperature: -65°C to +150°C
- Thermal Resistance: 45°C/W junction to lead at 3/8 (10 mm) lead length from body, or 105°C/W junction to ambient when mounted on FR4 PC board (1oz Cu) with 4 mm² copper pads and track width 1 mm, length 25 mm
- Steady-State Power: 2 watts at $T_L \leq 60^\circ\text{C}$ 3/8 inch (10 mm) from body, or 1.19 watts at $T_A = 25^\circ\text{C}$ when mounted on FR4 PC described for thermal resistance (also see Figure 1)
- Forward voltage @200 mA: 1.2 volts (maximum)
- Solder Temperatures: 260°C for 10 s (max)

MECHANICAL AND PACKAGING

- CASE: Void-free transfer molded thermosetting epoxy body meeting UL94V-0
- TERMINALS: Leads, tin-lead or RoHS compliant annealed matte-Tin plating solderable per MIL-STD-750, method 2026
- POLARITY: Cathode indicated by band where diode is to be operated with the banded end positive with respect to the opposite end for Zener regulation.
- MARKING: Part number
- TAPE & REEL option: Standard per EIA-296 (add "TR" suffix to part number)
- WEIGHT: 0.4 grams
- See package dimensions on last page



ELECTRICAL CHARACTERISTICS @ 25°C

MICRO TYPE NUMBER (Note 1)	NOMINAL ZENER VOLTAGE (Note 2)		MAXIMUM ZENER IMPEDANCE (Note 3)			MAXIMUM REVERSE CURRENT		MAXIMUM RATED ZENER CURRENT @ 100°C	MAXIMUM SURGE CURRENT (Note 4)
	V_Z @	I_{ZT}	Z_{ZT} @ I_{ZT}	Z_{ZK} @	I_{ZK}	I_R @	V_R	I_{ZM}	I_{ZSM}
	VOLTS	mA	OHMS	OHMS	mA	μA	VOLTS	mA	A
2EZ3.6D5	3.6	139	5.0	400	1.0	80	1.0	504	4.6
2EZ3.9D5	3.9	128	5.0	400	1.0	30	1.0	468	4.4
2EZ4.3D5	4.3	116	4.5	400	1.0	20	1.0	434	4.1
2EZ4.7D5	4.7	106	4.5	550	1.0	5.0	1.0	386	3.3
2EZ5.1D5	5.1	98	3.5	600	1.0	5.0	1.0	356	3.5
2EZ5.6D5	5.6	89.5	2.5	500	1.0	5.0	2.0	324	3.3
2EZ6.2D5	6.2	80.5	1.5	700	1.0	5.0	3.0	292	3.1
2EZ6.8D5	6.8	73.5	2.0	700	1.0	5.0	4.0	266	2.9
2EZ7.5D5	7.5	66.5	2.0	700	0.5	5.0	5.0	242	2.66
2EZ8.2D5	8.2	61	2.3	700	0.5	5.0	6.0	220	2.44
2EZ9.1D5	9.1	55	2.5	700	0.5	3.0	7.0	200	2.2
2EZ10D5	10	50	3.5	700	0.25	3.0	7.6	182	2.0
2EZ11D5	11	45.5	4.0	700	0.25	1.0	8.4	166	1.82
2EZ12D5	12	41.5	4.5	700	0.25	1.0	9.1	152	1.66
2EZ13D5	13	38.5	5.0	700	0.25	0.5	9.9	138	1.54
2EZ14D5	14	35.7	5.5	700	0.25	0.5	10.6	130	1.43
2EZ15D5	15	33.4	7.0	700	0.25	0.5	11.4	122	1.33
2EZ16D5	16	31.2	8.0	700	0.25	0.5	12.2	114	1.25
2EZ17D5	17	29.4	9.0	750	0.25	0.5	13.0	107	1.18
2EZ18D5	18	27.8	10	750	0.25	0.5	13.7	100	1.11
2EZ19D5	19	26.3	11	750	0.25	0.5	14.4	95	1.05
2EZ20D5	20	25	11	750	0.25	0.5	15.2	90	1.0
2EZ22D5	22	22.8	12	750	0.25	0.5	16.7	82	0.91
2EZ24D5	24	20.8	13	750	0.25	0.5	18.2	76	0.83
2EZ27D5	27	18.5	18	750	0.25	0.5	20.6	68	0.74
2EZ30D5	30	16.6	20	1000	0.25	0.5	22.5	60	0.67
2EZ33D5	33	15.1	23	1000	0.25	0.5	25.1	55	0.61
2EZ36D5	36	13.9	25	1000	0.25	0.5	27.4	50	0.56
2EZ39D5	39	12.8	30	1000	0.25	0.5	29.7	47	0.51
2EZ43D5	43	11.6	35	1500	0.25	0.5	32.7	43	0.45
2EZ47D5	47	10.6	40	1500	0.25	0.5	35.8	39	0.42
2EZ51D5	51	9.8	48	1500	0.25	0.5	38.8	36	0.39
2EZ56D5	56	9.0	55	2000	0.25	0.5	42.6	32	0.36
2EZ62D5	62	8.1	60	2000	0.25	0.5	47.1	29	0.32
2EZ68D5	68	7.4	75	2000	0.25	0.5	51.7	27	0.29
2EZ75D5	75	6.7	90	2000	0.25	0.5	56	24	0.27
2EZ82D5	82	6.1	100	3000	0.25	0.5	62.2	22	0.24
2EZ91D5	91	5.5	125	3000	0.25	0.5	69.2	20	0.22
2EZ100D5	100	5.0	175	3000	0.25	0.5	76.0	18	0.20
2EZ110D5	110	4.5	250	4000	0.25	0.5	83.6	17	0.18
2EZ120D5	120	4.2	325	4500	0.25	0.5	91.2	15	0.16
2EZ130D5	130	3.8	400	5000	0.25	0.5	98.8	14	0.15
2EZ140D5	140	3.6	500	5500	0.25	0.5	106.4	13	0.14
2EZ150D5	150	3.3	575	6000	0.25	0.5	114	12	0.13
2EZ160D5	160	3.1	650	6500	0.25	0.5	121.6	11	0.12
2EZ170D5	170	2.9	675	7000	0.25	0.5	130.4	11	0.12
2EZ180D5	180	2.8	725	7000	0.25	0.5	136.8	10	0.11
2EZ190D5	190	2.6	825	8000	0.25	0.5	144.8	10	0.10
2EZ200D5	200	2.5	900	8000	0.25	0.5	152	9	0.10

- NOTES:**
- Suffix 1 indicates +/-1% tolerance, suffix 2 indicates +/-2% tolerance, suffix 5 indicates +/-5% tolerance. Suffix 10 indicates +/-10%, no suffix indicates +/-20%.
 - The V_Z is measured after allowing a 90 second stabilization period when mounted with a 3/8" minimum lead length from body. Ambient temperature, $T_A = 25^\circ C (+8^\circ C/-2^\circ C)$.
 - The Zener impedance is derived from 60 cycle ac voltage resulting from an ac current having an rms value equal to 10% of the dc Zener current (I_{ZT} or I_{ZK}) is superimposed on I_{ZT} or I_{ZK} .
 - Maximum Surge Current I_{ZSM} is a non-recurrent maximum peak reverse surge with a pulse width of 8.3 ms.

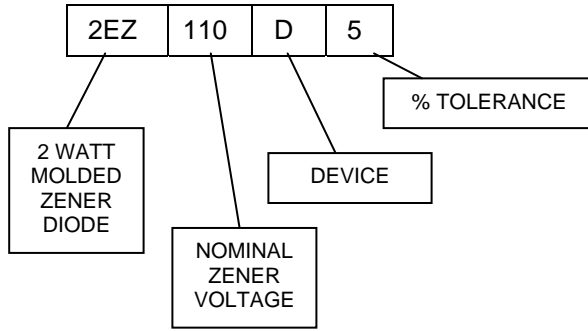

GRAPHS

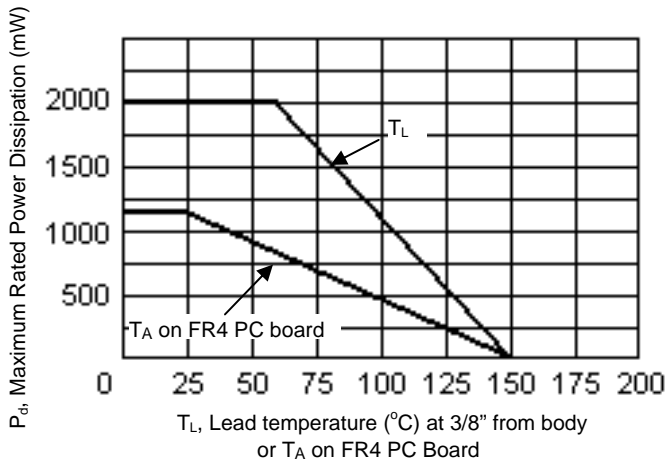

FIGURE 1
POWER DERATING CURVE

