

## DESCRIPTION

Schottky Barrier devices are currently available in single beamlead, dual “T”, ring quad and bridge quad configurations. Devices are available in monolithic form for hybrid applications as well as in hermetic or non-hermetic packages. Monolithic devices are recommended for highest frequency, broadband designs. The beamlead design eliminates the problems associated with wire bonding very small junction devices thus improving reliability and performance in MIC applications. Our in house epitaxy process capability insures repeatability for lowest conversion loss through Ku Band. A broad range of unique metallization schemes produce Microsemi’s complete line of barrier heights. Diodes are currently available with barrier heights as low as 240 mV and up to 625 mV per junction. By optimizing epitaxy and metallization, these devices achieve the lowest  $R_S-C_J$  products resulting in exceptional conversion loss performance. “High Rel” screening is available on packaged devices per your requirements.

This series of devices meets RoHS requirements per EU Directive 2002/95/EC.

## APPLICATIONS

Schottky barrier diodes are suitable for a variety of circuit applications ranging from single ended RF mixers to low level high speed switching. The monolithic beamlead design minimizes parasitic inductance and capacitance insuring repeatable performance through Ku band. Single junction devices such as the style ‘S12’ are well suited for RF Mixers, level detectors, phase detectors, modulators, etc. With junction capacitances as low as .06 pF, Monolithic Quads are ideally suited for broadband double balanced mixer designs through 26.5 GHz. The Ultra-Low Barrier devices (GC9900 Series) are designed for mixers with low or starved Local Oscillator levels where optimal conversion loss is a must. High barrier diodes, (GC9940 Series) are designed for applications where high drive levels are available, such as, Doppler mixers or motion detection. Schottky diodes are available in Ultra-Low, Medium and High Drive levels to fit virtually any circuit requirement.

## ABSOLUTE MAXIMUM RATINGS AT 25° C (UNLESS OTHERWISE SPECIFIED)

Rating	Symbol	Value	Unit
Maximum Power Handling	P	100	mW
Storage Temperature	T <sub>STG</sub>	-65 to +175	°C
Operating Temperature	T <sub>OP</sub>	-55 to +150	°C

### IMPORTANT:

For the most current data, consult our web site: [www.microsemi.com](http://www.microsemi.com)  
Specifications are subject to change. Consult factory for latest information.



These devices are ESD sensitive and must be handled use using ESD precautions.

## KEY FEATURES

- Monolithic design for lowest parasitics
- Low Conversion Loss
- Suitable for applications to 26.5 GHz
- Excellent Noise Figure
- Available in low, medium and high barrier heights
- Can be supplied as monolithic devices for hybrid applications or as packaged devices
- RoHS Compliant<sup>1</sup>

<sup>1</sup> These devices are supplied with Gold plated terminations. Consult factory for details.

## APPLICATIONS/BENEFITS

- Mixers
- Level Detectors
- Phase Detectors

**CHIP ELECTRICAL PARAMETERS @ 25°C (unless otherwise specified)**

Model <sup>1</sup> Number	Barrier Height	Freq Range	V <sub>B</sub> (V) <sup>2</sup> I <sub>r</sub> =10μA (Min)	C <sub>J</sub> (pF) <sup>3</sup> @0V (Max)	V <sub>F</sub> (mV) @1 mA (Max)	R <sub>D</sub> (Ω) @5 mA (Max)	NF <sub>SSB</sub> (dB) <sup>4</sup> (Typ)	Z <sub>IF</sub> (Ω) <sup>5</sup> (Typ)
GC9901	ULTRA LOW	Ku-Ka	2.0	0.10	340	20	6.5	140
GC9902		X		0.15	310	16	6	
GC9903		C		0.30	300	14	5.5	
GC9904		S		0.50	280	12	5.5	
GC9911	LOW	Ku-Ka	2.0	0.10	360	20	6.5	170
GC9912		X		0.15	350	16	6	
GC9913		C		0.30	340	14	5.5	
GC9914		S		0.50	330	12	5.5	
GC9921	LOW- MED	Ku-Ka	2.0	0.10	470	20	6.5	200
GC9922		X		0.15	460	16	6	
GC9923		C		0.30	440	14	5.5	
GC9924		S		0.50	420	12	5.5	
GC9931	MEDIUM	Ku-Ka	3.0	0.10	550	20	6.75	250
GC9932		X		0.15	540	16	6.25	
GC9933		C		0.30	530	14	5.75	
GC9934		S		0.50	510	12	5.5	
GC9941	HIGH	Ku-Ka	4.0	0.10	660	20	7	300
GC9942		X		0.15	640	16	6.25	
GC9943		C		0.30	630	14	5.75	
GC9944		S		0.50	610	12	5.75	

**Notes**

- When ordering, specify appropriate package style.  
IE: Order GC9901-S12 for single beamlead configuration.
- V<sub>b</sub> measured at 10μA (N/A on ring quads).
- 0 Volts, F=1 MHz (diagonal leads on quads).
- L.O. = 0 dBm, N<sub>r</sub> = 1.5 dB, F = 10 GHz
- L.O. = 0 dBm

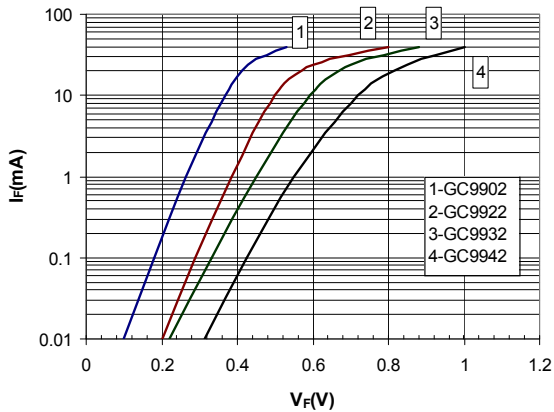
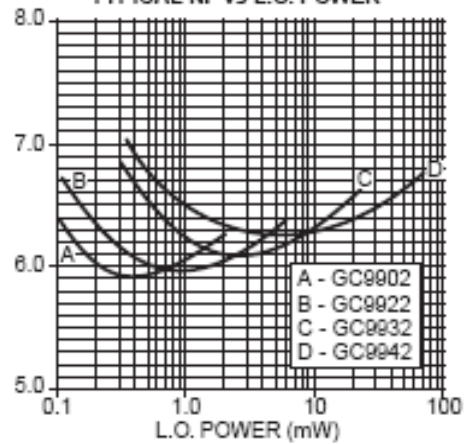
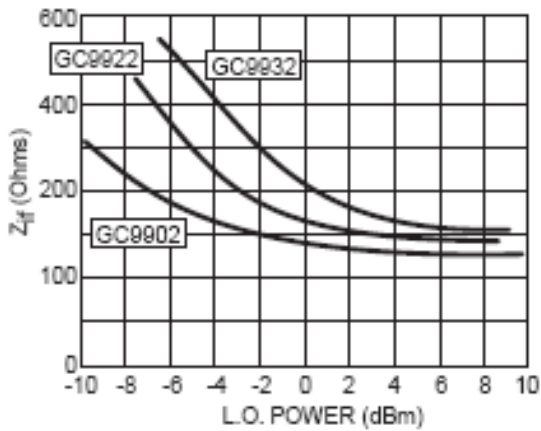
**VF CURVES**
**TYPICAL NF CURVES**
**Typical I-V Curves**

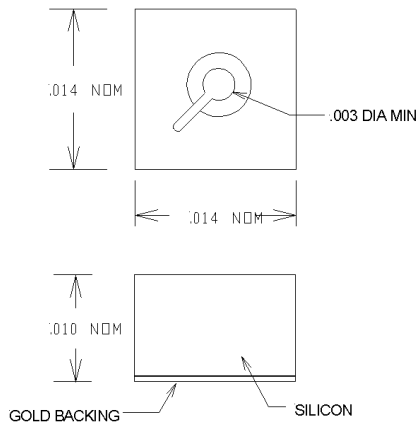
**TYPICAL NF vs L.O. POWER**

**TYPICAL IF IMPEDANCE CURVES**
**TYPICAL  $Z_{if}$  vs L.O. POWER**

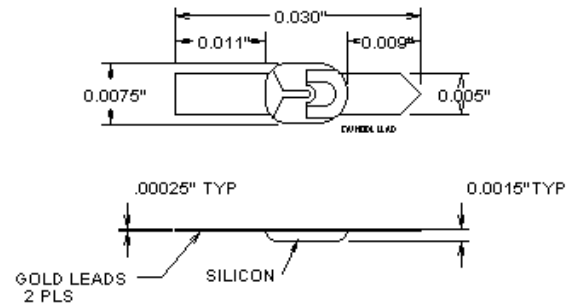
**PACKAGE STYLE UC**

Order as GC9900-UC

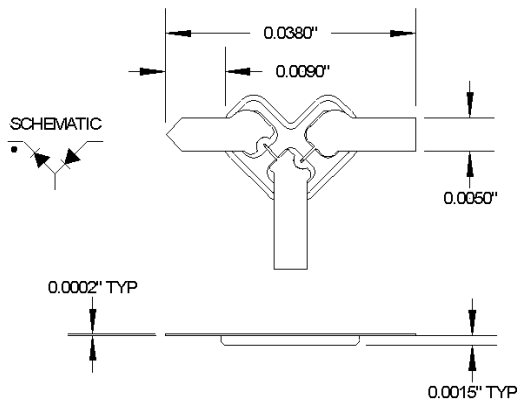
**PACKAGE STYLE S12**

Order as GC9900-S12

**PACKAGE STYLE TSR**

ORDER AS GC9900-TSR

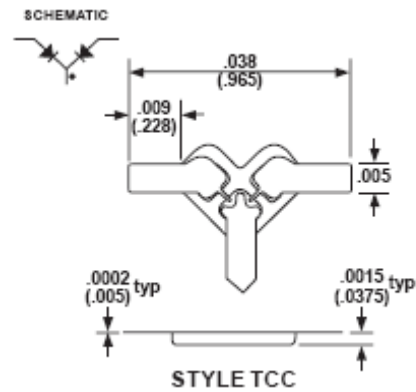
**PACKAGE STYLE TCC**

ORDER AS GC9900-TCC

Also available as TCA ('T' Common Anode)

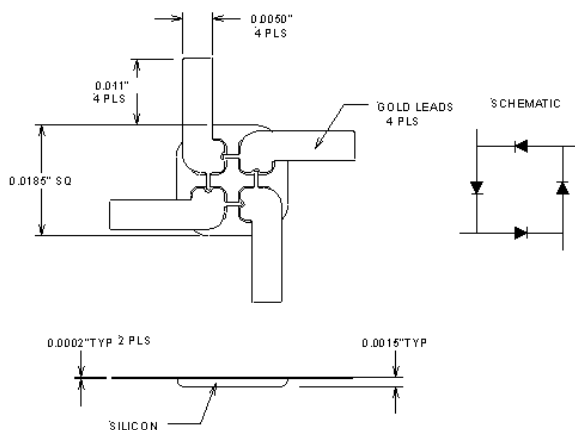
**PACKAGE STYLE QR1**

ORDER AS GC9900-QR1

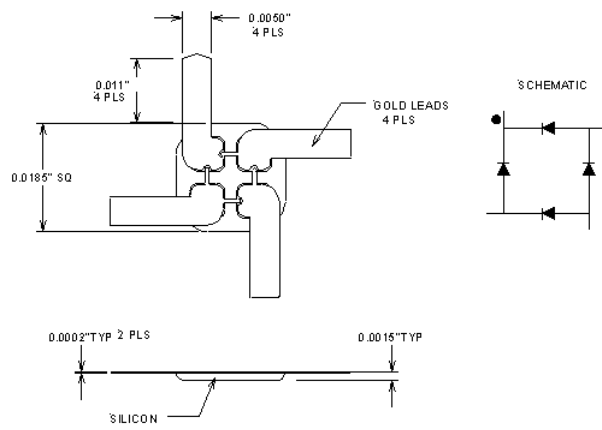
**PACKAGE STYLE QB1**

ORDER AS GC9900-QB1

**DISCRETE AND MONOLITHIC PACKAGE OPTIONS**

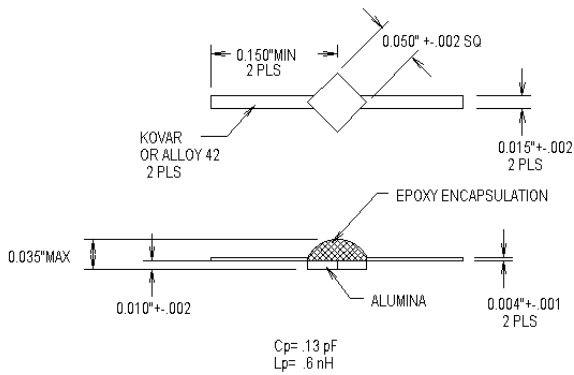
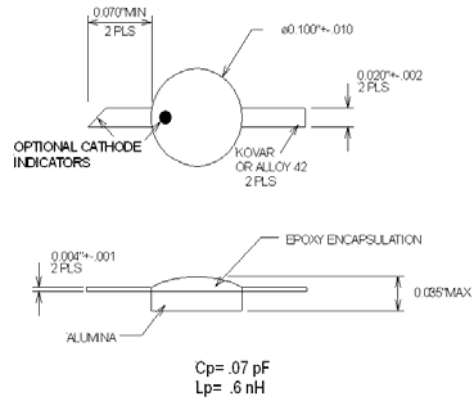
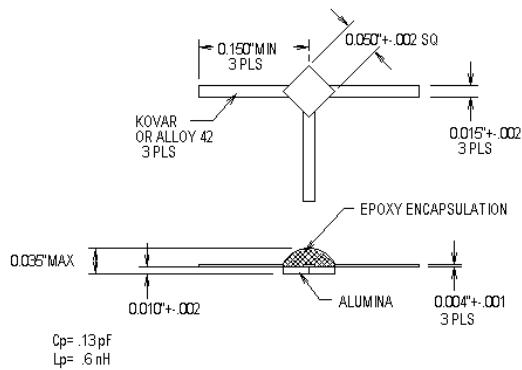
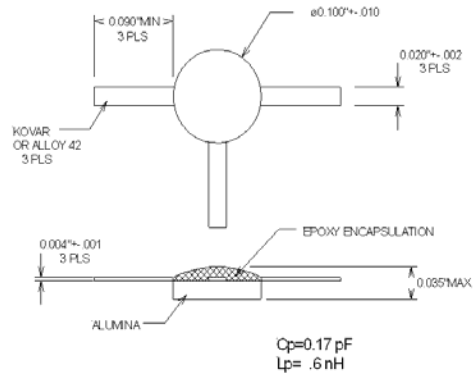
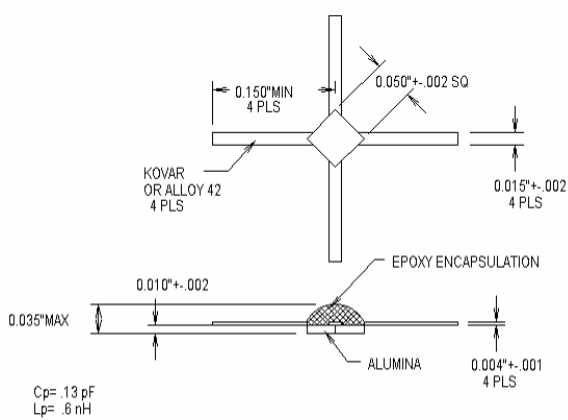
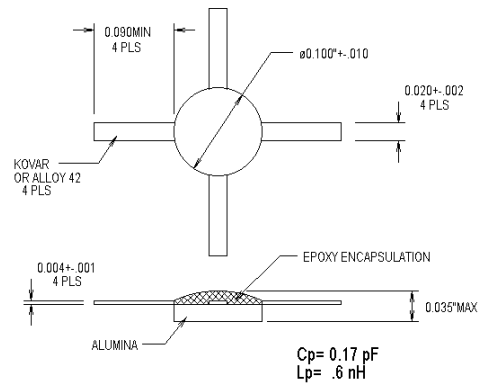
**PACKAGE STYLE 127A**

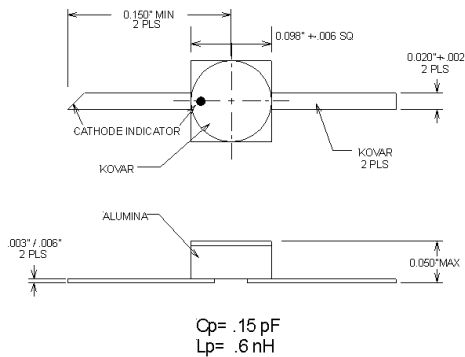
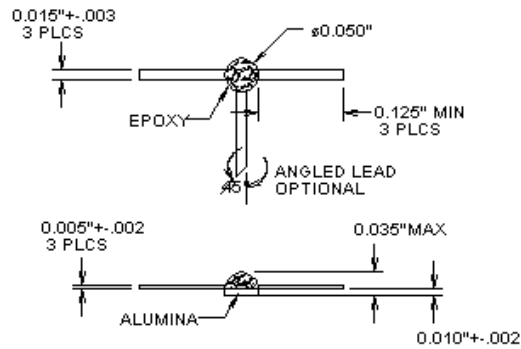
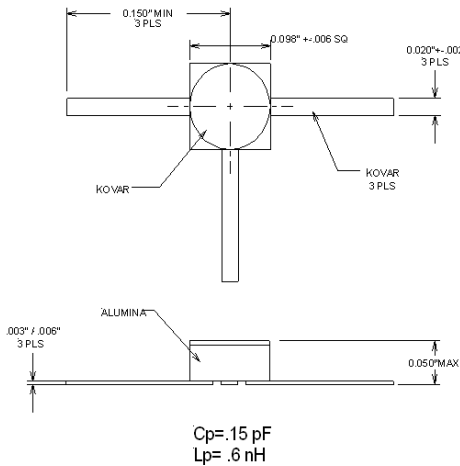
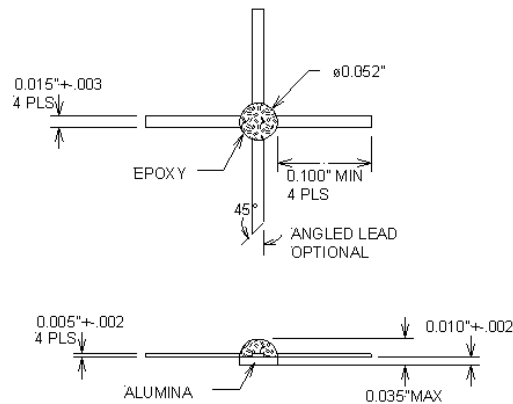
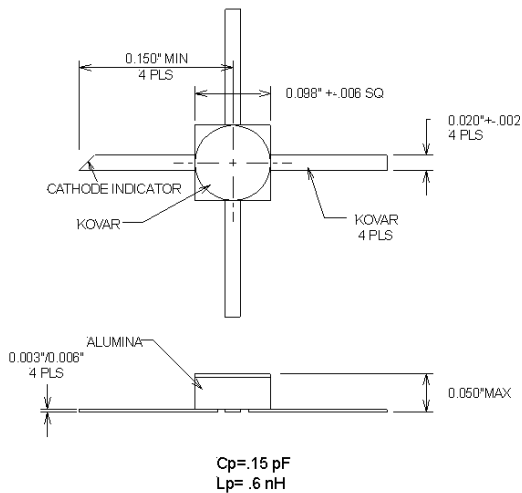
**PACKAGE STYLE 128A**

**PACKAGE STYLE 127B**

**PACKAGE STYLE 128B**

**PACKAGE STYLE 127C**

**PACKAGE STYLE 128C**

**NON HERMETIC EPOXY COATED PACKAGES**

**PACKAGE STYLE 129A**

**STYLE 174B**

**PACKAGE STYLE 129B**

**STYLE 174C**

**PACKAGE STYLE 129C**

**ORDERING INFORMATION**

Package style and configuration should be included when ordering 3 and 4 terminal products.  
Format: partnum – pkg – config

For example:

- Order a ring quad in a 128C package as:  
GC9901-128C-QR1
- Order a bridge quad in a 128C package as:  
GC9901-128C-QB1

Consult Factory for assistance.

**OTHER PACKAGE STYLES AVAILABLE ON REQUEST**