

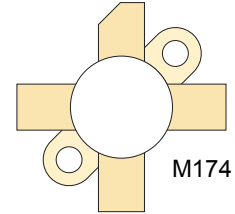

RF POWER VERTICAL MOSFET

The VRF151 is a gold-metallized silicon n-channel RF power transistor designed for broadband commercial and military applications requiring high power and gain without compromising reliability, ruggedness, or inter-modulation distortion.



FEATURES

- Improved Ruggedness $V_{(BR)DSS} = 170V$
- 150W with 22dB Typical Gain @ 30MHz, 50V
- 150W with 14dB Typical Gain @ 175MHz, 50V
- Excellent Stability & Low IMD
- Common Source Configuration
- Available in Matched Pairs
- 30:1 Load VSWR Capability at Specified Operating Conditions
- Nitride Passivated
- Refractory Gold Metallization
- High Voltage Replacement for MRF151
- RoHS Compliant 

Maximum Ratings

All Ratings: $T_c = 25^\circ C$ unless otherwise specified

| Symbol | Parameter | VRF151(MP) | Unit |
|-----------|---|------------|------|
| V_{DSS} | Drain-Source Voltage | 170 | V |
| I_D | Continuous Drain Current @ $T_c = 25^\circ C$ | 16 | A |
| V_{GS} | Gate-Source Voltage | ± 40 | V |
| P_D | Total Device dissipation @ $T_c = 25^\circ C$ | 300 | W |
| T_{STG} | Storage Temperature Range | -65 to 150 | °C |
| T_J | Operating Junction Temperature | 200 | |

Static Electrical Characteristics

| Symbol | Parameter | Min | Typ | Max | Unit |
|---------------|--|-----|-----|-----|---------|
| $V_{(BR)DSS}$ | Drain-Source Breakdown Voltage ($V_{GS} = 0V, I_D = 100mA$) | 170 | 180 | | V |
| $V_{DS(ON)}$ | On State Drain Voltage ($I_{D(ON)} = 10A, V_{GS} = 10V$) | | 2.0 | 3.0 | |
| I_{DSS} | Zero Gate Voltage Drain Current ($V_{DS} = 100V, V_{GS} = 0V$) | | | 1 | mA |
| I_{GSS} | Gate-Source Leakage Current ($V_{DS} = \pm 20V, V_{GS} = 0V$) | | | 1.0 | μA |
| g_{fs} | Forward Transconductance ($V_{DS} = 10V, I_D = 5A$) | 5.0 | | | mhos |
| $V_{GS(TH)}$ | Gate Threshold Voltage ($V_{DS} = 10V, I_D = 100mA$) | 2.9 | 3.6 | 4.4 | V |

Thermal Characteristics

| Symbol | Characteristic | Min | Typ | Max | Unit |
|-----------------|-------------------------------------|-----|-----|------|------|
| $R_{\theta JC}$ | Junction to Case Thermal Resistance | | | 0.60 | °C/W |

 **CAUTION:** These Devices are Sensitive to Electrostatic Discharge. Proper Handling Procedures Should Be Followed.

Dynamic Characteristics

VRF151(MP)

| Symbol | Parameter | Test Conditions | Min | Typ | Max | Unit |
|-----------|------------------------------|--|-----|-----|-----|------|
| C_{iss} | Input Capacitance | $V_{GS} = 0V$ $V_{DS} = 150V$ $f = 1MHz$ | | 375 | | pF |
| C_{oss} | Output Capacitance | | | 200 | | |
| C_{rss} | Reverse Transfer Capacitance | | | 12 | | |

Functional Characteristics

| Symbol | Parameter | Min | Typ | Max | Unit |
|----------------------|--|--------------------------------|-----|-----|------|
| G_{PS} | $f_1 = 30MHz, f_2 = 30.001MHz, V_{DD} = 50V, I_{DQ} = 250mA, P_{out} = 150W_{PEP}$ | 18 | 22 | | dB |
| G_{PS} | $f = 175MHz, V_{DD} = 50V, I_{DQ} = 250mA, P_{out} = 150W$ | | 14 | | |
| η_D | $f_1 = 30MHz, f_2 = 30.001MHz, V_{DD} = 50V, I_{DQ} = 250mA, P_{out} = 150W_{PEP}$ | | 50 | | % |
| IMD _(d3) | $f_1 = 30MHz, f_2 = 30.001MHz, V_{DD} = 50V, I_{DQ} = 250mA, P_{out} = 150W_{PEP}^1$ | | -30 | | dBc |
| IMD _(d11) | $f_1 = 30MHz, f_2 = 30.001MHz, V_{DD} = 50V, I_{DQ} = 250mA, P_{out} = 150W_{PEP}$ | | -60 | | |
| Ψ | $f_1 = 30MHz, f_2 = 30.001MHz, V_{DD} = 50V, I_{DQ} = 250mA, P_{out} = 150W_{PEP}$ 30:1 VSWR - All Phase Angles | No Degradation in Output Power | | | |

Class A Characteristics

| Symbol | Test Conditions | Min | Typ | Max | Unit |
|-------------------------|---|-----|-----|-----|------|
| G_{PS} | $f = 30MHz, V_{DD} = 50V, I_{DQ} = 250mA, P_{out} = 150W_{PEP}$ | | 20 | | dB |
| IMD _(d3) | $f = 30MHz, V_{DD} = 50V, I_{DQ}(\text{Max}) = 3.75A, P_{out} = 150W_{PEP}$ | | -50 | | |
| IMD _(d9-d13) | $f = 30MHz, V_{DD} = 50V, I_{DQ} = 250mA, P_{out} = 150W_{PEP}$ | | -75 | | |

1. To MIL-STD-1311 Version A, test method 2204B, Two Tone, Reference Each Tone

Microsemi reserves the right to change, without notice, the specifications and information contained herein.

Typical Performance Curves

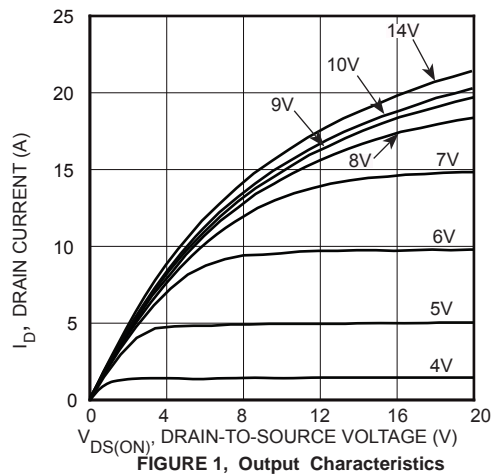

FIGURE 1, Output Characteristics

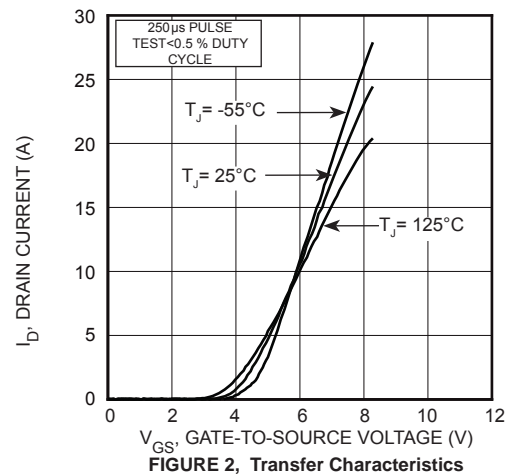

FIGURE 2, Transfer Characteristics

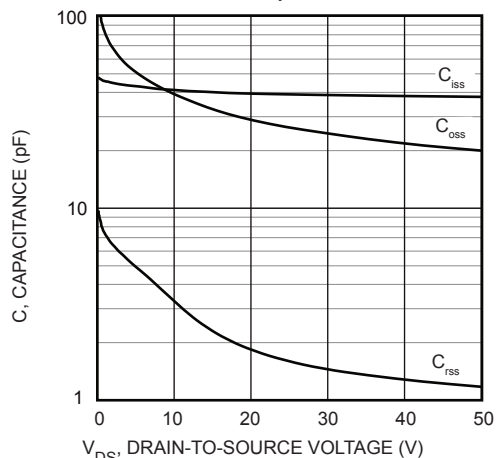

FIGURE 3, Capacitance vs Drain-to-Source Voltage

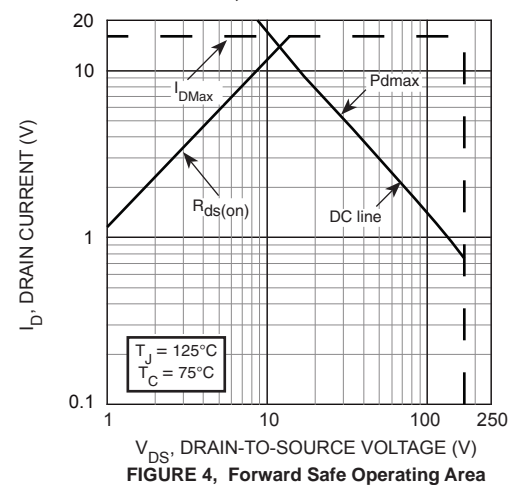

FIGURE 4, Forward Safe Operating Area

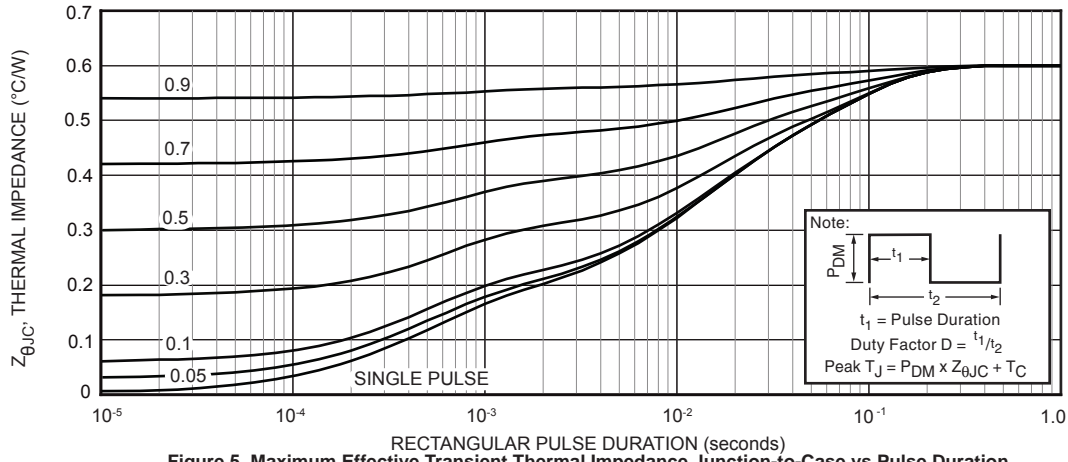

Figure 5. Maximum Effective Transient Thermal Impedance Junction-to-Case vs Pulse Duration

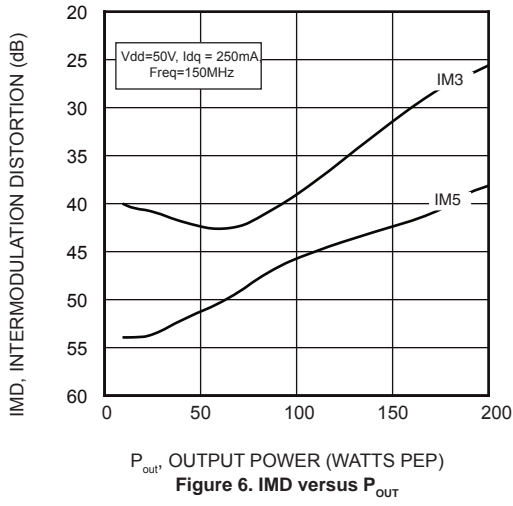

Figure 6. IMD versus P_{OUT}

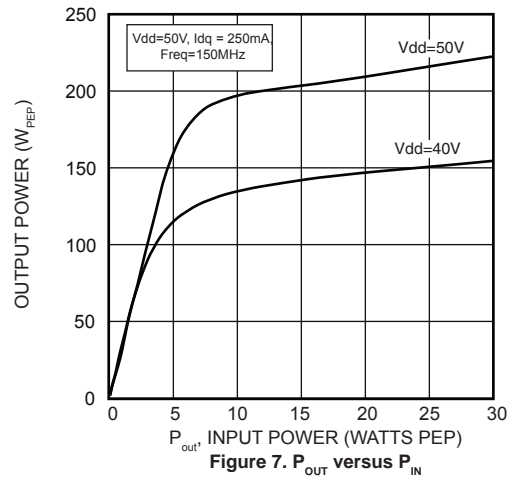
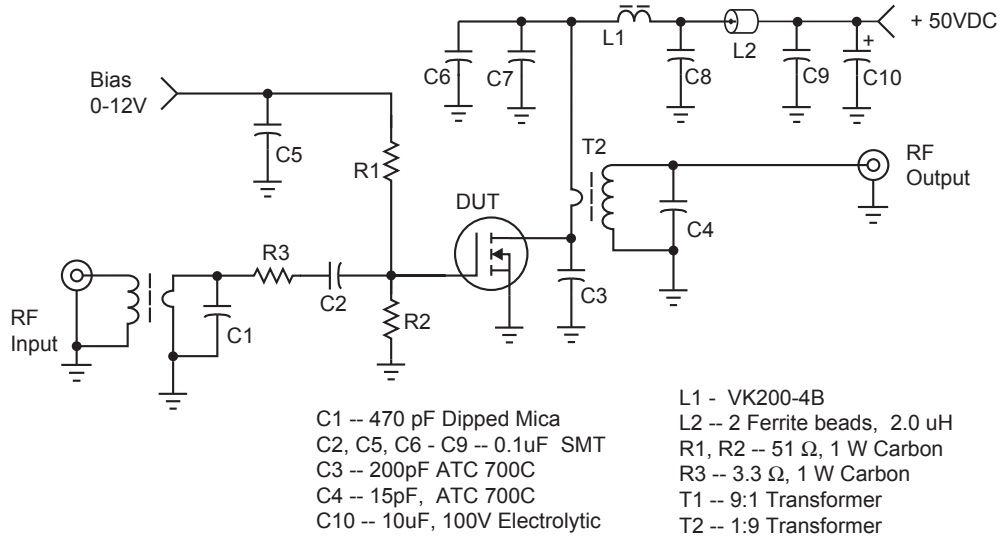
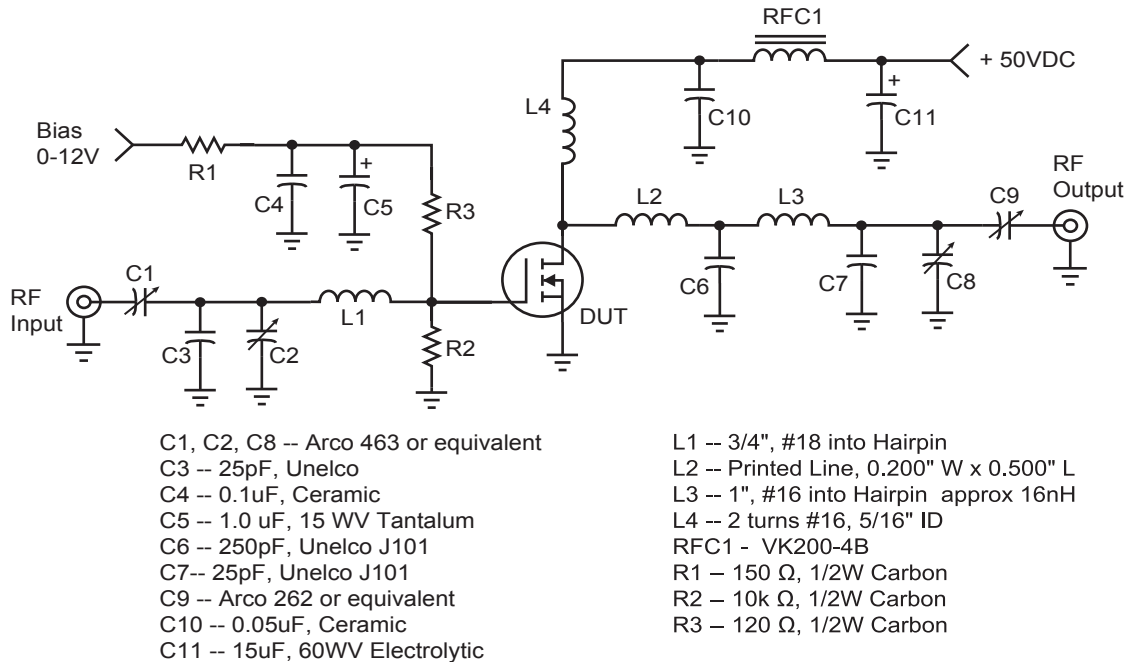

Figure 7. P_{OUT} versus P_{IN}

30 MHz test Circuit



175 MHz test Circuit



Adding MP at the end of P/N specifies a matched pair where $V_{GS(TH)}$ is matched between the two parts. V_{TH} values are marked on the devices per the following table.

| Code | Vth Range | Code 2 | Vth Range |
|------|---------------|--------|---------------|
| A | 2.900 - 2.975 | M | 3.650 - 3.725 |
| B | 2.975 - 3.050 | N | 3.725 - 3.800 |
| C | 3.050 - 3.125 | P | 3.800 - 3.875 |
| D | 3.125 - 3.200 | R | 3.875 - 3.950 |
| E | 3.200 - 3.275 | S | 3.950 - 4.025 |
| F | 3.275 - 3.350 | T | 4.025 - 4.100 |
| G | 3.350 - 3.425 | W | 4.100 - 4.175 |
| H | 3.425 - 3.500 | X | 4.175 - 4.250 |
| J | 3.500 - 3.575 | Y | 4.250 - 4.325 |
| K | 3.575 - 3.650 | Z | 4.325 - 4.400 |

V_{TH} values are based on Microsemi measurements at datasheet conditions with an accuracy of 1.0%.

**.5" SOE Package Outline
All Dimensions are ± .005**

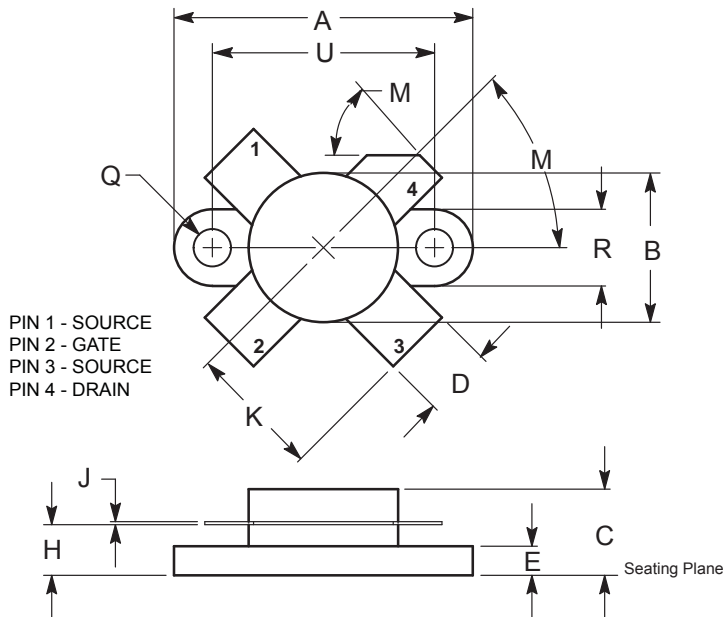

| DIM | INCHES | | MILLIMETERS | |
|-----|---------|-------|-------------|-------|
| | MIN | MAX | MIN | MAX |
| A | 0.096 | 0.990 | 24.39 | 25.14 |
| B | 0.465 | 0.510 | 11.82 | 12.95 |
| C | 0.229 | 0.275 | 5.82 | 6.98 |
| D | 0.216 | 0.235 | 5.49 | 5.96 |
| E | 0.084 | 0.110 | 2.14 | 2.79 |
| H | 0.144 | 0.178 | 3.66 | 4.52 |
| J | 0.003 | 0.007 | 0.08 | 0.17 |
| K | 0.435 | | 11.0 | |
| M | 45° NOM | | 45° NOM | |
| Q | 0.115 | 0.130 | 2.93 | 3.30 |
| R | 0.246 | 0.255 | 6.25 | 6.47 |
| U | 0.720 | 0.730 | 18.29 | 18.54 |

Microsemi's products are covered by one or more of U.S. patents 4,895,810 5,045,903 5,089,434 5,182,234 5,019,522 5,262,336 6,503,786 5,256,583 4,748,103 5,283,202 5,231,474 5,434,095 5,528,058 6,939,743, 7,352,045 5,283,201 5,801,417 5,648,283 7,196,634 6,664,594 7,157,886 6,939,743 7,342,262 and foreign patents. US and Foreign patents pending. All Rights Reserved.