

RF POWER VERTICAL MOSFET

The VRF157FL is a gold-metallized silicon n-channel RF power transistor designed for broadband commercial and military applications requiring high power and gain without compromising reliability, ruggedness, or inter-modulation distortion.

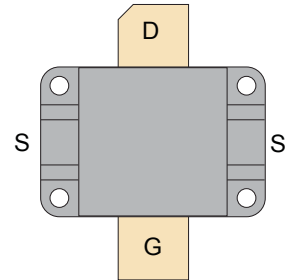

FEATURES

- Improved Ruggedness $V_{(BR)DSS} = 170V$
- 600W with 21dB Typical Gain @ 30MHz, 50V
- Excellent Stability & Low IMD
- Common Source Configuration
- Available in Matched Pairs
- Nitride Passivated
- Economical Flangeless Package
- Refractory Gold Metallization
- High Voltage Replacement for MRF157
- RoHS Compliant 

Maximum Ratings

All Ratings: $T_c = 25^\circ C$ unless otherwise specified

Symbol	Parameter	VRF157FL(MP)	Unit
V_{DSS}	Drain-Source Voltage	170	V
I_D	Continuous Drain Current @ $T_c = 25^\circ C$	60	A
V_{GS}	Gate-Source Voltage	± 40	V
P_D	Total Device dissipation @ $T_c = 25^\circ C$	1350	W
T_{STG}	Storage Temperature Range	-65 to 150	°C
T_J	Operating Junction Temperature Max	200	

Static Electrical Characteristics

Symbol	Parameter	Min	Typ	Max	Unit
$V_{(BR)DSS}$	Drain-Source Breakdown Voltage ($V_{GS} = 0V, I_D = 100mA$)	170	180		V
$V_{DS(ON)}$	On State Drain Voltage ($I_{D(ON)} = 40A, V_{GS} = 10V$)		3.0	5.0	
I_{DSS}	Zero Gate Voltage Drain Current ($V_{DS} = 100V, V_{GS} = 0V$)			4.0	mA
I_{GSS}	Gate-Source Leakage Current ($V_{DS} = \pm 20V, V_{GS} = 0V$)			4.0	μA
g_{fs}	Forward Transconductance ($V_{DS} = 10V, I_D = 20A$)	16			mhos
$V_{GS(TH)}$	Gate Threshold Voltage ($V_{DS} = 10V, I_D = 100mA$)	2.9	3.6	4.4	V

Thermal Characteristics

Symbol	Characteristic	Min	Typ	Max	Unit
$R_{\theta JC}$	Junction to Case Thermal Resistance			0.13	°C/W
$R_{\theta JHS}$	Junction to Sink Thermal Resistance (Use High Efficiency Thermal Joint Compound and Planar Heat Sink Surface.)		0.22		

 **CAUTION:** These Devices are Sensitive to Electrostatic Discharge. Proper Handling Procedures Should Be Followed.

Dynamic Characteristics

VRF157FL(MP)

Symbol	Parameter	Test Conditions	Min	Typ	Max	Unit
C_{iss}	Input Capacitance	$V_{GS} = 0V$		1580		pF
C_{oss}	Output Capacitance	$V_{DS} = 50V$		810		
C_{rss}	Reverse Transfer Capacitance	$f = 1MHz$		65		

Functional Characteristics

Symbol	Parameter	Min	Typ	Max	Unit
G_{PS}	$f = 30MHz, V_{DD} = 50V, I_{DQ} = 800mA, P_{out} = 600W$	17	21		dB
η_D	$f = 30MHz, V_{DD} = 50V, I_{DQ} = 800mA, P_{out} = 600W_{PEP}$		45		%
$IMD_{(dB)}$	$f1 = 30MHz, f2 = 30.001MHz, V_{DD} = 50V, I_{DQ} = 800mA, P_{out} = 600W_{PEP}^1$		-25		dBc

1. To MIL-STD-1311 Version A, test method 2204B, Two Tone, Reference Each Tone

Microsemi reserves the right to change, without notice, the specifications and information contained herein.

Typical Performance Curves

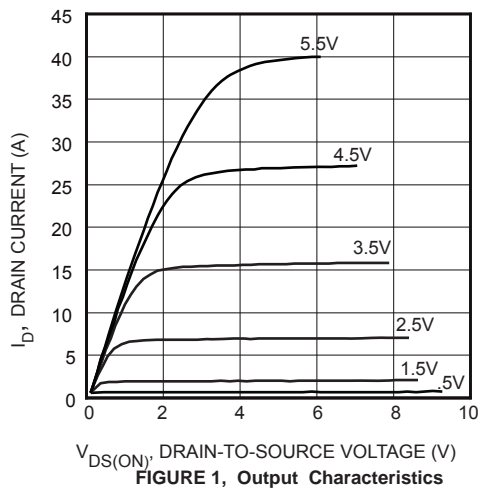

FIGURE 1, Output Characteristics

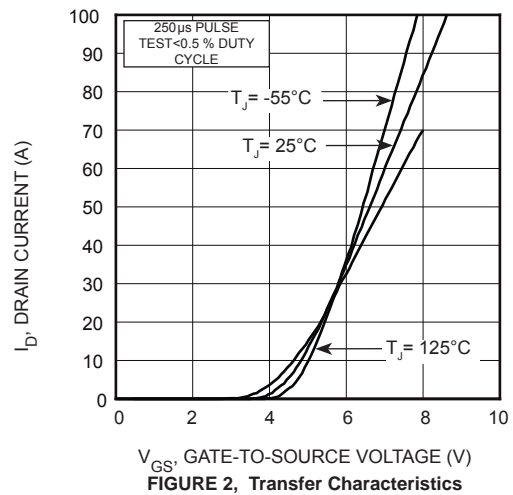

FIGURE 2, Transfer Characteristics

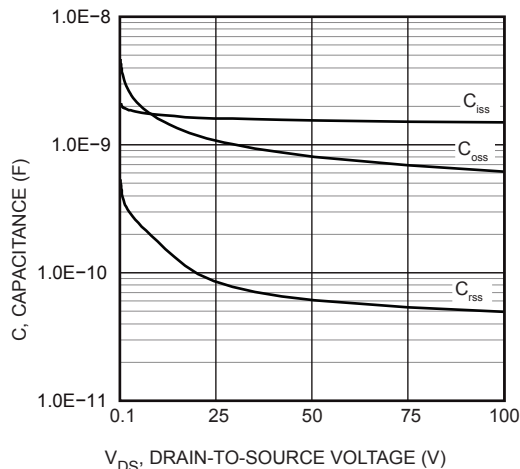

FIGURE 3, Capacitance vs Drain-to-Source Voltage

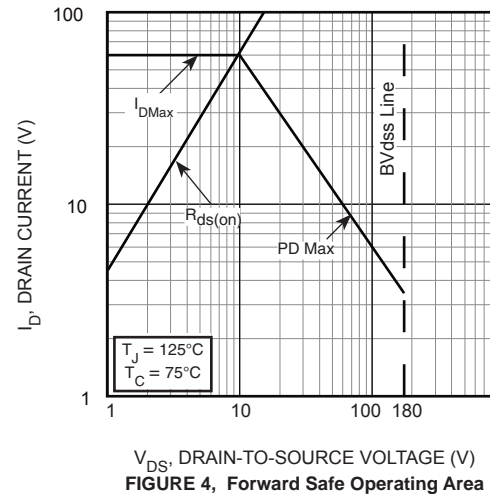

FIGURE 4, Forward Safe Operating Area

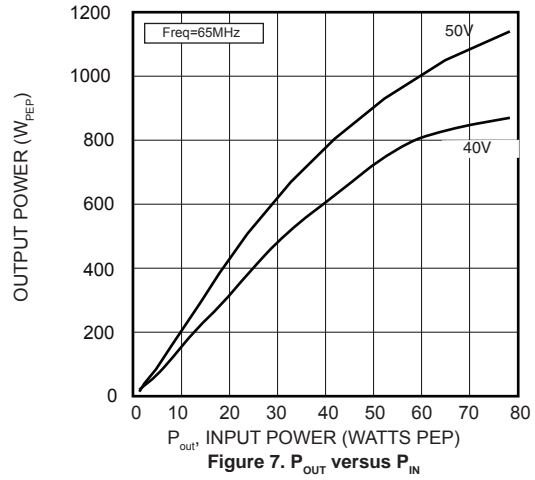
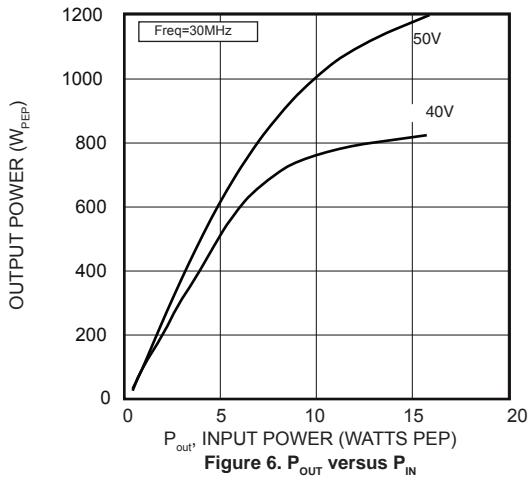
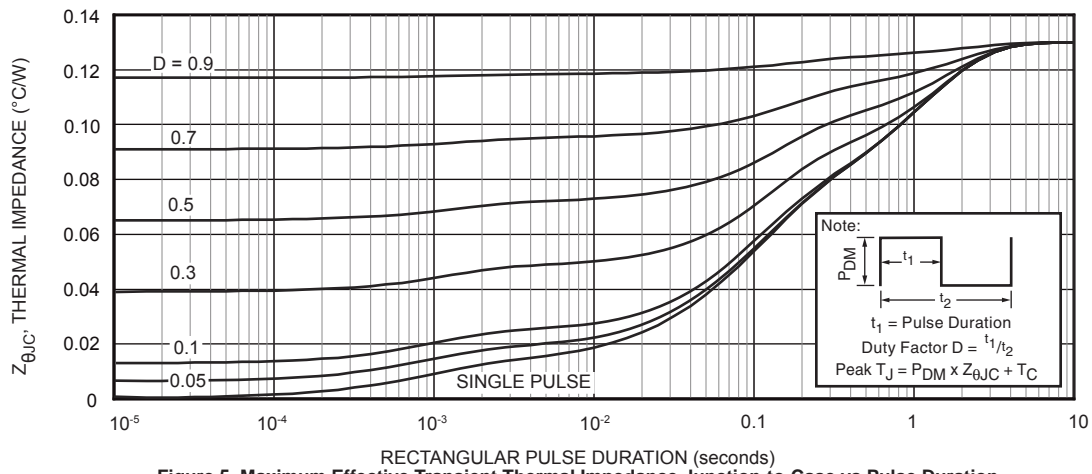
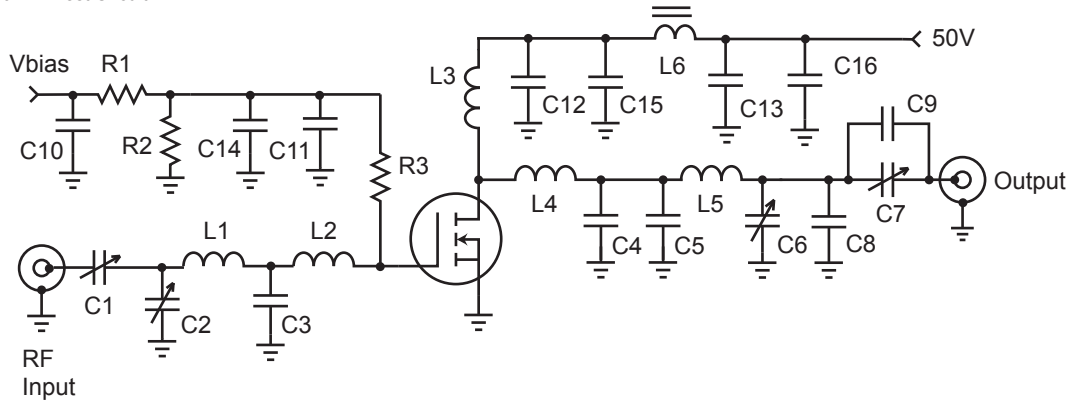
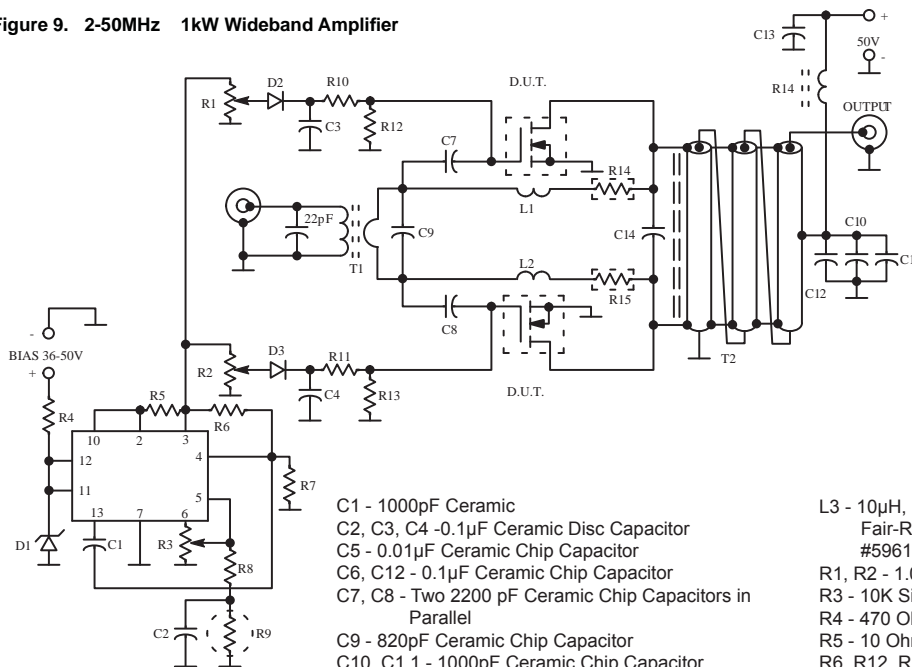

Figure 8. 30MHz Test Circuit



- | | |
|--------------------------------------|--------------------------------------|
| C1, C2, C6, C7 ARCO 465 mica trimmer | L1 110nH 4t #22 0.312"d .30" |
| C3 1800pF ATC700B ceramic | L2 29nH 2t #22 .188" dia .10" l |
| C4 680pF metal clad 500V mica | L3 0.3uH - 6t #16 enam. .5" dia. |
| C5 390pF metal clad 500V mica | L4 22nH - 1t #16 enam. .375" dia. |
| C8 100pF ATC 700E ceramic | L5 117nH - 3t #16 enam. .5" dia. .3" |
| C9 120pF ATC 700E ceramic | L6 1t #16 on 2x 267300081 .5" bead |
| C10 - C13 .01uF 100V ceramic SMT | R1-R2 1kW 1/4W |
| C14 - C16 .1uF 100V ceramic SMT | R3 10W 1/4W |

Figure 9. 2-50MHz 1kW Wideband Amplifier



- | | |
|--|--|
| C1 - 1000pF Ceramic | L3 - 10μH, 10 Turns #12 AWG Enameled Wire on Fair-Rite Products Corp. Ferrite Toroid #5961000401 or Equivalent |
| C2, C3, C4 - 0.1μF Ceramic Disc Capacitor | R1, R2 - 1.0K Single Turn Trimpots |
| C5 - 0.01μF Ceramic Chip Capacitor | R3 - 10K Single Turn Trimpot |
| C6, C12 - 0.1μF Ceramic Chip Capacitor | R4 - 470 Ohms, 2.0 Watts |
| C7, C8 - Two 2200 pF Ceramic Chip Capacitors in Parallel | R5 - 10 Ohms |
| C9 - 820pF Ceramic Chip Capacitor | R6, R12, R13 - 2.0K Ohms |
| C10, C11 - 1000pF Ceramic Chip Capacitor | R7 - 10K Ohms |
| C13 - 0.47μF Ceramic Chip Capacitor or Two Smaller Values in Parallel | R8 - Exact Value Depends on Thermistor R9 used (Typically 5.0 - 10K) |
| C14 - Unencapsulated Mica, 500V Two 1000pF Units in Series, Mounted Under T2 | R9 - Thermistor, Keystone RL1009-5820-97-D1 or Equivalent |
| D1 - IN5357A or Equivalent | R10, R11 - 100 Ohms, 1.0W Carbon |
| D2, D3 - IN4148 or Equivalent | R14, R15 - EMC Technology Model 5308 or KDI Pyrofilm PPR 970-150-3 Power Resistors, 25 Ohms |
| C1 - MC1723 (723) Voltage Regulator | T1, T2 - 9:1 and 1:9 Impedance Ratio RF Transformers |
| L1, L2 - 15 nH Connecting Wires to R14 and R15, 2.5cm Each #20 AWG | |

Adding MP at the end of P/N specifies a matched pair where $V_{GS(TH)}$ is matched between the two parts. V_{TH} values are marked on the devices per the following table.

Code	Vth Range	Code 2	Vth Range
A	2.900 - 2.975	M	3.650 - 3.725
B	2.975 - 3.050	N	3.725 - 3.800
C	3.050 - 3.125	P	3.800 - 3.875
D	3.125 - 3.200	R	3.875 - 3.950
E	3.200 - 3.275	S	3.950 - 4.025
F	3.275 - 3.350	T	4.025 - 4.100
G	3.350 - 3.425	W	4.100 - 4.175
H	3.425 - 3.500	X	4.175 - 4.250
J	3.500 - 3.575	Y	4.250 - 4.325
K	3.575 - 3.650	Z	4.325 - 4.400

V_{TH} values are based on Microsemi measurements at datasheet conditions with an accuracy of 1.0%.

Thermal Considerations and Package Mounting:

The rated 1350W power dissipation is only available when the package mounting surface is at 25°C and the junction temperature is 200°C. The thermal resistance between junctions and case mounting surface is 0.13°C/W. When installed, an additional thermal impedance of 0.09°C/W between the package base and the mounting surface is smooth and flat. Thermal joint compound must be used to reduce the effects of small surface irregularities. The heatsink should incorporate a copper heat spreader to obtain best results.

The lid maintains the required mounting pressure while allowing for thermal expansion of both the device and the heat sink. Four 6-32 (M3.5) screws provide the minimum 125 lb. required mounting force. T=4-6 in-lb. Please refer to App Note 1802 "Mounting Instructions for Flangeless Packages."

HAZARDOUS MATERIAL WARNING

The ceramic portion of the device between leads and mounting flange is beryllium oxide. Beryllium oxide dust is highly toxic when inhaled. Care must be taken during handling and mounting to avoid damage to this area. These devices must never be thrown away with general industrial or domestic waste.

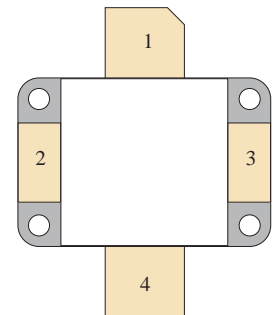
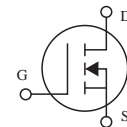
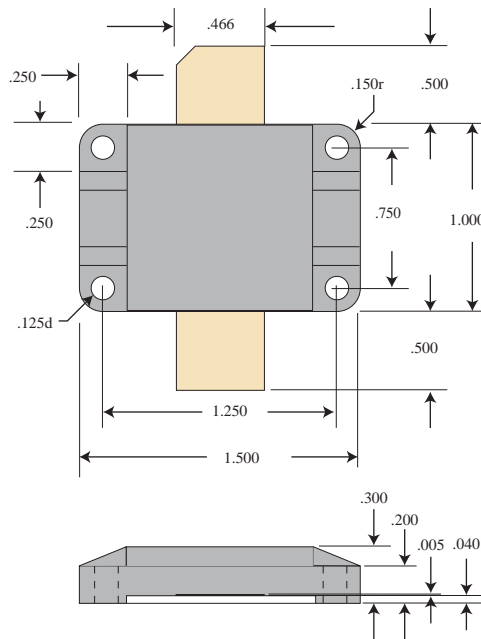

PIN 1 - DRAIN
 PIN 2 - SOURCE
 PIN 3 - SOURCE
 PIN 4 - GATE

Microsemi's products are covered by one or more of U.S. patents 4,895,810 5,045,903 5,089,434 5,182,234 5,019,522 5,262,336 6,503,786 5,256,583 4,748,103 5,283,202 5,231,474 5,434,095 5,528,058 6,939,743, 7,352,045 5,283,201 5,801,417 5,648,283 7,196,634 6,664,594 7,157,886 6,939,743 7,342,262 and foreign patents. US and Foreign patents pending. All Rights Reserved.