

RF POWER MOSFET
 N-CHANNEL ENHANCEMENT MODE

The ARF521 is an RF power transistor designed for high voltage operation in broadband HF, narrow band ISM and MRI power amplifiers up to 150MHz.

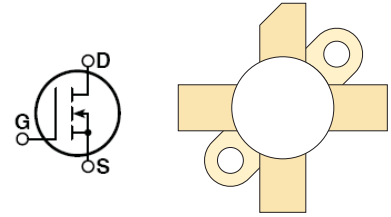

- Specified 125 Volt, 81MHz Characteristics:
 - Output Power = 150 Watts.
 - Gain = 13dB (Class AB)
 - Efficiency = 50%
- High Voltage Breakdown and Large SOA for Superior Ruggedness.
- Industry Standard Package
- Low Vth Thermal Coefficient

Maximum Ratings
All Ratings: $T_c = 25^\circ\text{C}$ unless otherwise specified

| Symbol | Parameter | ARF521 | Unit |
|----------------|-----------------------------------------------------|------------|------|
| V_{DSS} | Drain-Source Voltage | 500 | V |
| I_D | Continuous Drain Current @ $T_c = 25^\circ\text{C}$ | 10 | A |
| V_{GS} | Gate-Source Voltage | ± 30 | V |
| P_D | Total Device Dissipation @ $T_c = 25^\circ\text{C}$ | 250 | W |
| T_J, T_{STG} | Operating and Storage Junction Temperature Range | -55 to 175 | °C |
| T_L | Lead Temperature: 0.063" from Case for 10 Sec. | 300 | |

Static Electrical Characteristics

| Symbol | Parameter | Min | Typ | Max | Unit |
|---------------|-----------------------------------------------------------------------------------------|-----|------|-----------|---------------|
| $V_{(BR)DSS}$ | Drain-Source Breakdown Voltage ($V_{GS} = 0V, I_D = 250 \mu\text{A}$) | 500 | | | V |
| $V_{DS(ON)}$ | Drain-Source On-State Resistance ¹ ($I_{D(ON)} = 5A, V_{GS} = 10V$) | | 0.56 | 0.8 | Ω |
| I_{DSS} | Zero Gate Voltage Drain Current ($V_{DS} = V_{DSS}, V_{GS} = 0V$) | | | 25 | μA |
| | Zero Gate Voltage Drain Current ($V_{DS} = 50V, V_{GS} = 0, T_c = 125^\circ\text{C}$) | | | 250 | |
| I_{GSS} | Gate-Source Leakage Current ($V_{DS} = \pm 30V, V_{GS} = 0V$) | | | ± 100 | nA |
| g_{fs} | Forward Transconductance ($V_{DS} = 15V, I_D = 5A$) | 3 | 3.6 | | mhos |
| $V_{GS(TH)}$ | Gate Threshold Voltage ($V_{DS} = V_{GS}, I_D = 200\text{mA}$) | 2 | | 4 | Volts |

Thermal Characteristics

| Symbol | Characteristic | Min | Typ | Max | Unit |
|-----------------|-----------------------------------------------------------------------------------------|-----|-----|------|------|
| $R_{\theta JC}$ | Junction to Case Thermal Resistance | | | 0.60 | °C/W |
| $R_{\theta CS}$ | Case to Sink (Use High Efficiency Thermal Joint Compound and Planar Heat Sink Surface.) | | 0.1 | | |

 **CAUTION:** These Devices are Sensitive to Electrostatic Discharge. Proper Handling Procedures Should Be Followed.

Dynamic Characteristics

ARF521

| Symbol | Parameter | Test Conditions | Min | Typ | Max | Unit |
|--------------|------------------------------|----------------------------------------------------------------------------------------------|-----|-----|-----|------|
| C_{ISS} | Input Capacitance | $V_{GS} = 0V$ | | 780 | 900 | pF |
| C_{OSS} | Output Capacitance | $V_{DS} = 50V$ | | 125 | 150 | |
| C_{RSS} | Reverse Transfer Capacitance | $f = 1MHz$ | | 7 | 10 | |
| $t_{d(ON)}$ | Turn-on Delay Time | $V_{GS} = 15V$ $V_{DD} = 0.5V_{DSS}$ $I_D = I_{D[Cont.]} @ 25^\circ C$ $R_G = 1.6W$ | | 5.1 | 10 | ns |
| t_r | Rise Time | | | 4.1 | 8 | |
| $t_{d(off)}$ | Turn-off Delay Time | | | 12 | 18 | |
| t_f | Fall Time | | | 4.0 | 7 | |

Functional Characteristics

| Symbol | Characteristic | Test Conditions | Min | Typ | Max | Unit |
|----------|------------------------------------|---------------------------------|--------------------------------|-----|-----|------|
| G_{PS} | Common Source Amplifier Power Gain | $f = 81MHz$ | 14 | 15 | | dB |
| h | Drain Efficiency | $I_{dq} = 50mA$ $V_{DD} = 125V$ | 50 | 55 | | % |
| y | Electrical Ruggedness VSWR 5:1 | $P_{OUT} = 150W$ | No Degradation in Output Power | | | |

1. Pulse Test: Pulse width < 380 μ S, Duty Cycle < 2%.

Microsemi reserves the right to change, without notice, the specifications and information contained herein.

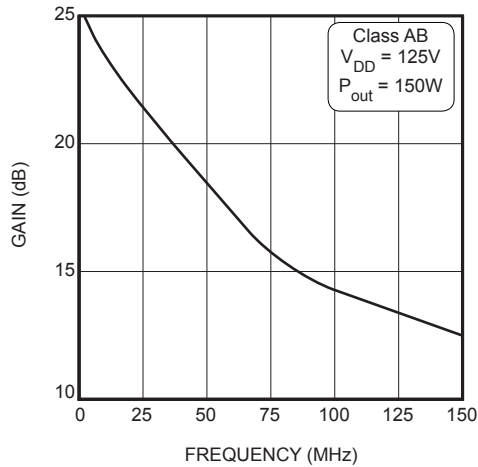

Figure 1, Typical Gain vs. Frequency

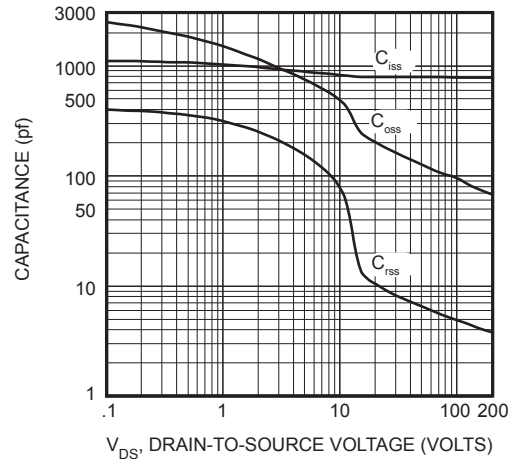

Figure 2, Typical Capacitance vs. Drain-to-Source Voltage

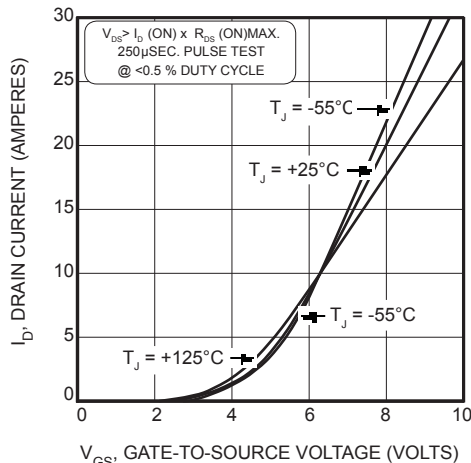

Figure 3, Typical Transfer Characteristics

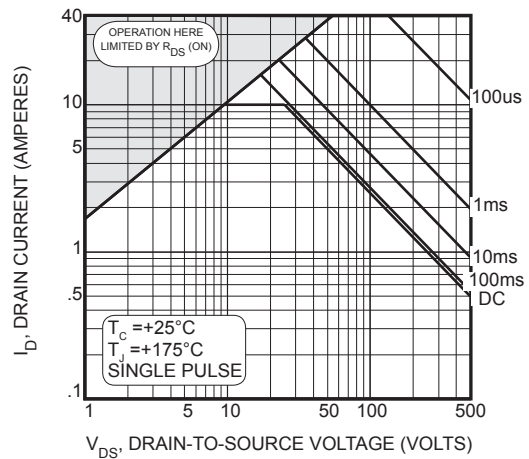

Figure 4, Typical Maximum Safe Operating Area

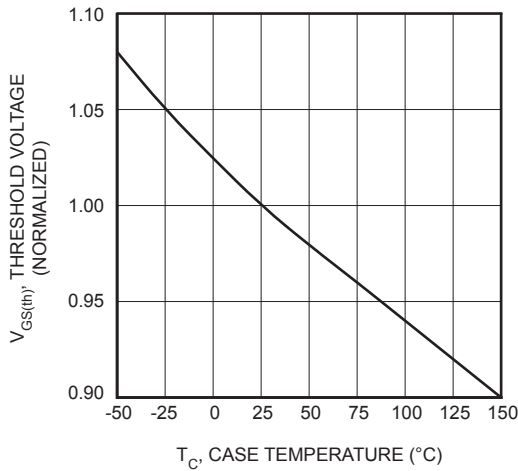

Figure 5, Typical Threshold Voltage vs Temperature

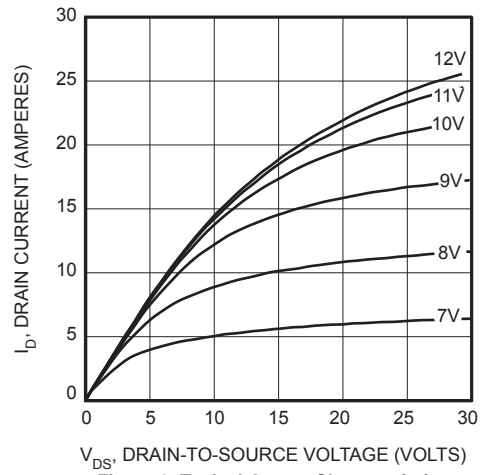

Figure 6, Typical Output Characteristics

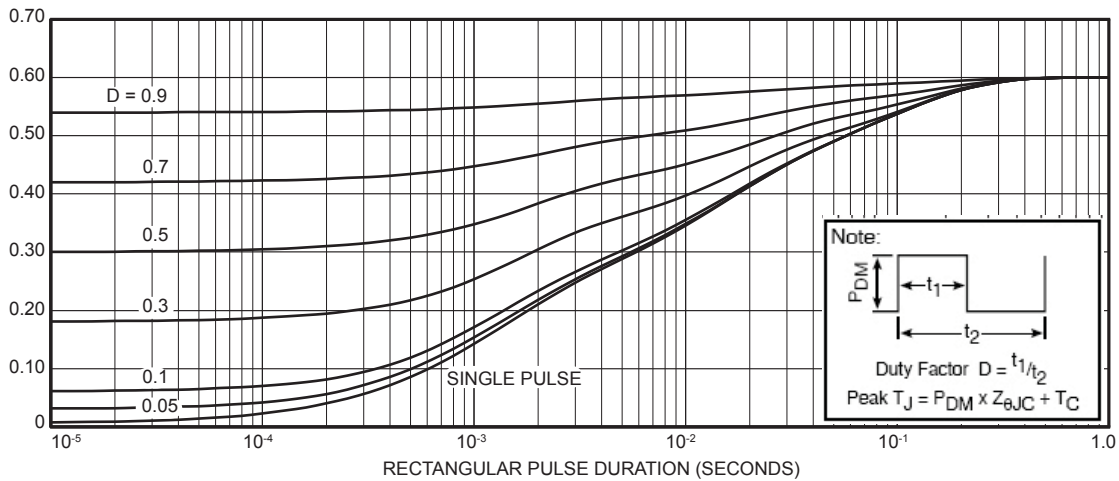

FIGURE 7a, MAXIMUM EFFECTIVE TRANSIENT THERMAL IMPEDANCE, JUNCTION-TO-CASE vs PULSE DURATION

Transient Thermal Impedance RC Model

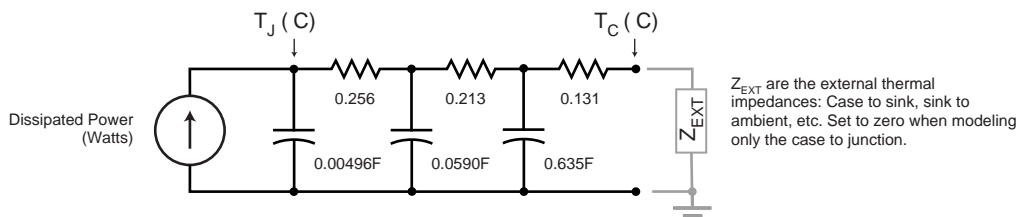

Figure 7b, TRANSIENT THERMAL IMPEDANCE MODEL

Table 1 - Typical Class AB Large Signal Input - Output Impedance

| Freq. (MHz) | Z _{in} (Ω) | Z _{OL} (Ω) |
|-------------|---------------------|---------------------|
| 2.0 | 24 - j 4.5 | 55 - j 4 |
| 13.5 | 8.3 - j 11.6 | 45 - j 22 |
| 27 | 2.5 - j 7.1 | 28.7 - j 28 |
| 40 | 1.0 - j 4.2 | 17.9 - j 26 |
| 65 | .30 - j 1.1 | 9.0 - j 20.6 |
| 80 | .25 + j 0.3 | 5.8 - j 17 |
| 100 | .35 + j 1.6 | 4 - j 14.2 |

Z_{IN} - Gate shunted with 25Ω I_{dq} = 50mA
 Z_{OL} - Conjugate of optimum load for 150 Watts output at V_{dd}=125V

ARF521 Test Circuit 81.36 MHz

ARF521

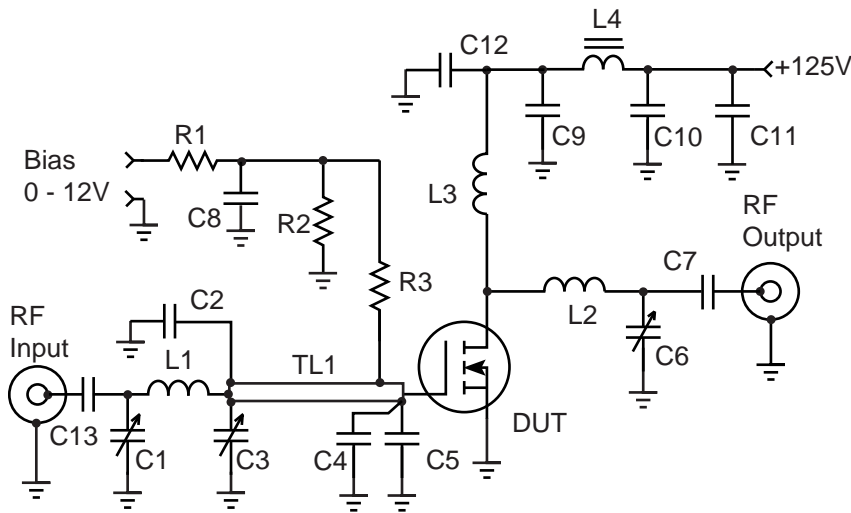

- C1 - Arco 406 Mica trimmer
- C2 - 220pF Semco metal clad
- C3 - Arco 464 Mica trimmer
- C4 - 820pF ATC 700B
- C5- 1000pF ATC 700B
- C6 - Arco 463 Mica trimmer
- C7-C10 10nF 500V chip
- C11-C13 1nF NPO 500V
- TL1 - .23" x 1.5" stripline
- L1 -- 2t #18 .3" ID .2"L ~50nH
- L2 -- 3t #16 AWG .31" ID .3"L ~65nH
- L3 -- 10t #22 AWG .25 ID ~470nH
- L4 -- VK200-4B ferrite choke ~3uH
- R1-R3 -- 1k Ohm 1/4W Carbon
- DUT = ARF521

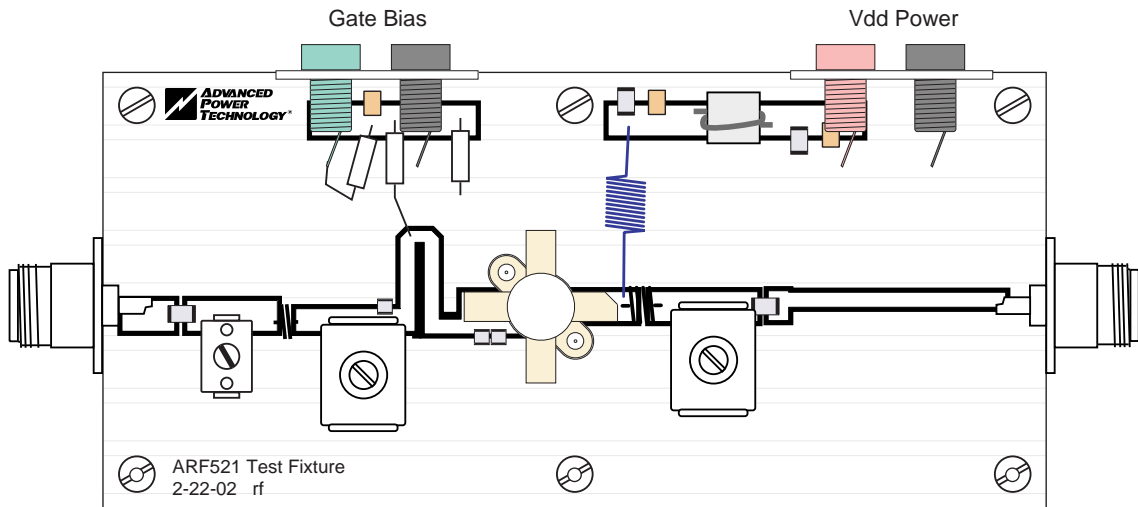

M174 Package Outline .5" SOE

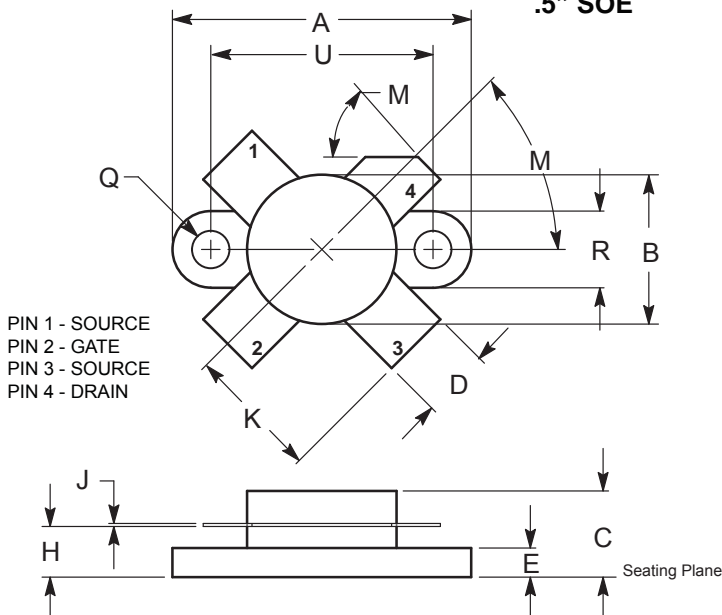

| DIM | INCHES | | MILLIMETERS | |
|-----|---------|-------|-------------|-------|
| | MIN | MAX | MIN | MAX |
| A | 0.096 | 0.990 | 24.39 | 25.14 |
| B | 0.465 | 0.510 | 11.82 | 12.95 |
| C | 0.229 | 0.275 | 5.82 | 6.98 |
| D | 0.216 | 0.235 | 5.49 | 5.96 |
| E | 0.084 | 0.110 | 2.14 | 2.79 |
| H | 0.144 | 0.178 | 3.66 | 4.52 |
| J | 0.003 | 0.007 | 0.08 | 0.17 |
| K | 0.435 | | 11.0 | |
| M | 45° NOM | | 45° NOM | |
| Q | 0.115 | 0.130 | 2.93 | 3.30 |
| R | 0.246 | 0.255 | 6.25 | 6.47 |
| U | 0.720 | 0.730 | 18.29 | 18.54 |

Microsemi's products are covered by one or more of U.S. patents 4,895,810 5,045,903 5,089,434 5,182,234 5,019,522 5,262,336 6,503,786 5,256,583 4,748,103 5,283,202 5,231,474 5,434,095 5,528,058 6,939,743 and foreign patents. US and Foreign patents pending. All Rights Reserved.