

MSC1015MP

**RF AND MICROWAVE TRANSISTORS
AVIONICS APPLICATIONS**

Features

- DESIGNED FOR HIGH POWER PULSED IFF, DME, TACAN APPLICATIONS
- 20 W (typ.) IFF 1030 – 1090 MHz
- 15 W (min.) DME 1025 – 1150 MHz
- 15 W (typ.) TACAN 960 –1215 MHz
- REFRACTORY GOLD METALLIZATION
- EMITTER BALLASTING AND LOW THERMAL RESISTANCE FOR RELIABILITY AND RUGGEDNESS
- 20:1 LOAD VSWR CAPABILITY AT SPECIFIED OPERATING CONDITIONS
- INPUT MATCHED, COMMON BASE CONFIGURATION

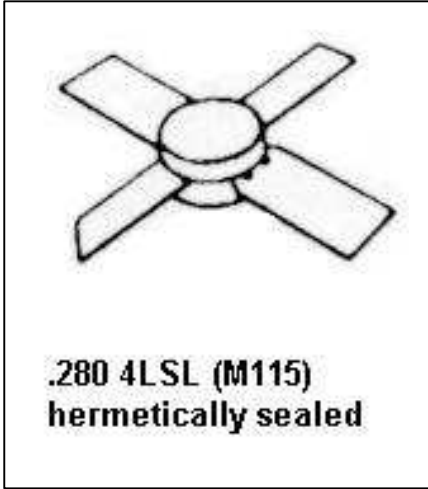

DESCRIPTION:

The MSC1015MP is a gold-metallized, epitaxial, silicon NPN power transistor designed for applications requiring high peak power and low duty cycles, such as IFF, DME, and TACAN. It is packaged in the .280" input-matched stripline package, resulting in improved broadband performance and low thermal resistance.

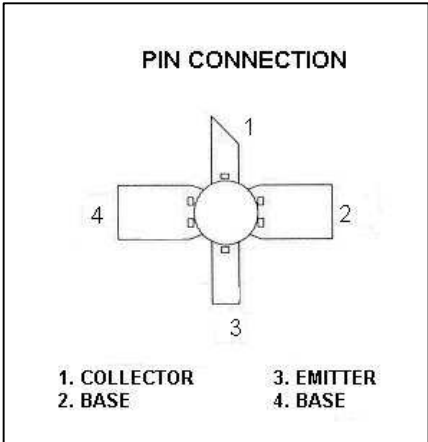

ABSOLUTE MAXIMUM RATINGS (T_{case} = 25°C)

Symbol	Parameter	Value	Unit
V _{CBO}	Collector-Base Voltage	65	V
V _{CES}	Collector-Emitter Voltage	65	V
V _{EBO}	Emitter-Base Voltage	3.5	V
I _C	Device Current	1.5	A
P _{DISS}	Power Dissipation	87.5	W
T _J	Junction Temperature	+ 200	°C
T _{STG}	Storage Temperature	-65 to +150	°C

THERMAL DATA

R _{TH(j-c)}	Junction-Case Thermal Resistance	2	°C/W
----------------------	----------------------------------	---	------

ELECTRICAL SPECIFICATIONS (T_{case} = 25°C)
STATIC

Symbol	Test Conditions	Value			Units
		Min.	Typ.	Max.	
BV_{CBO}	I_C = 10 mA I_E = 0 mA	65			V
BV_{CES}	I_C = 25 mA V_{BE} = 0 V	65			V
BV_{EBO}	I_E = 1 mA I_C = 0 mA	3.5			V
I_{CES}	V_{CE} = 50 V I_E = 0 mA			2	
h_{FE}	V_{CE} = 5 V I_C = .1 A	10		200	

DYNAMIC

Symbol	Test Conditions	Value			Units
		Min.	Typ.	Max.	
P_{OUT}	f = 1025 – 1150 MHz P_{IN} = 1.5 W V_{CE} = 50 V	15			W
G_P	f = 1025 – 1150 MHz P_{IN} = 1.5 W V_{CE} = 50 V	10			dB
ç_C	f = 1025 – 1150 MHz P_{IN} = 1.5 W V_{CE} = 50 V	30			%

Note: Pulse width = 10µSec
 Duty Cycle = 1%

IMPEDANCE DATA

Freq. (MHz)	Z _{IN} (Ω)	Z _{CL} (Ω)
960	2.5 + j 12.5	17.0 + j 15.5
1030	3.5 + j 12.5	17.0 + j 14.5
1090	3.0 + j 13.5	19.5 + j 12.5
1150	3.5 + j 14.0	18.0 + j 12.0
1215	5.0 + j 17.0	16.0 + j 12.0

PACKAGE MECHANICAL DATA

