

MS1503

**RF & MICROWAVE TRANSISTORS
WIDE BAND VHF/UHF APPLICATIONS**

Features

- 400 MHz
- 28 VOLTS
- GOLD METALIZATION
- P_{OUT} = 100 WATTS
- G_P = 7.0 dB GAIN MINIMUM
- COMMON EMITTER CONFIGURATION

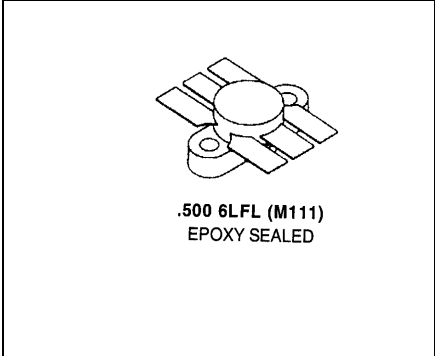

DESCRIPTION:

The MS1503 is a 28V Class C epitaxial silicon NPN planar transistor designed primarily for UHF communications. The device utilizes diffused emitter resistors to achieve infinite VSWR capability under operating conditions. Internal impedance matching produces optimum power gain and efficiency over the 225-400MHz band.

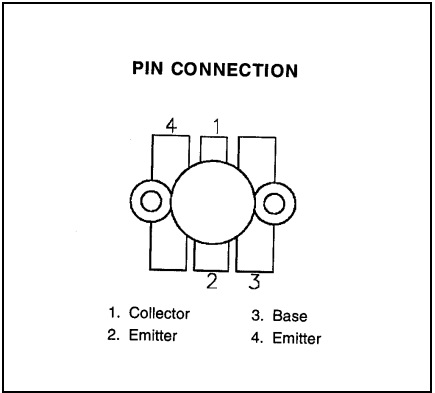

ABSOLUTE MAXIMUM RATINGS (T_{case} = 25°C)

Symbol	Parameter	Value	Unit
V _{CBO}	Collector-Base Voltage	60	V
V _{CEO}	Collector-Emitter Voltage	33	V
V _{EBO}	Emitter-Base Voltage	4.0	V
I _C	Device Current	4.0	A
P _{DISS}	Power Dissipation	250	W
T _J	Junction Temperature	+200	°C
T _{STG}	Storage Temperature	-65 +150	°C

Thermal Data

R _{TH(J-C)}	Thermal Resistance Junction-case	0.7	°C/W
----------------------	----------------------------------	-----	------

**ELECTRICAL SPECIFICATIONS (T_{case} = 25°C)
STATIC**

Symbol	Test Conditions		Value			Unit
			Min.	Typ.	Max.	
BV_{CBO}	I_C = 100 mA	I_E = 0 V	60	---	---	V
BV_{CEO}	I_C = 50 mA	I_B = 0 mA	33	---	---	V
BV_{EBO}	I_E = 20 mA	I_C = 0 mA	4.0	---	---	V
I_{CES}	V_{CB} = 28 V	I_E = 0 mA	---	---	25	mA
HFE	V_{CE} = 5 V	I_C = 1 A	20	---	200	---

DYNAMIC

Symbol	Test Conditions			Value			Unit
				Min.	Typ.	Max.	
P_{OUT}	f = 400 MHz	P_{IN} = 20W	V_{CE} = 28V	100	---	---	W
G_p	f = 400 MHz	P_{IN} = 20W	V_{CE} = 28V	7.0	---	---	dB
η_c	f = 400 MHz	P_{IN} = 20W	V_{CE} = 28V	50	---	---	%
Cob	f = 1 MHz	V_{CB} = 28V		---	---	105	pf

IMPEDANCE DATA

FREQ	Z _{IN} (Ω)	Z _{CL} (Ω)
225 MHz	1.3 + j1.8	5.4 – j0.5
300 MHz	1.1 + j2.4	3.9 – j0.7
350 MHz	0.8 + j3.0	2.6 – j1.0
375 MHz	0.75 + j3.5	2.2 – j1.4
400 MHz	0.70 + j3.6	1.8 – j1.9

P_{IN} = 20 W
V_{CE} = 28 V

PACKAGE MECHANICAL DATA

PACKAGE STYLE M111

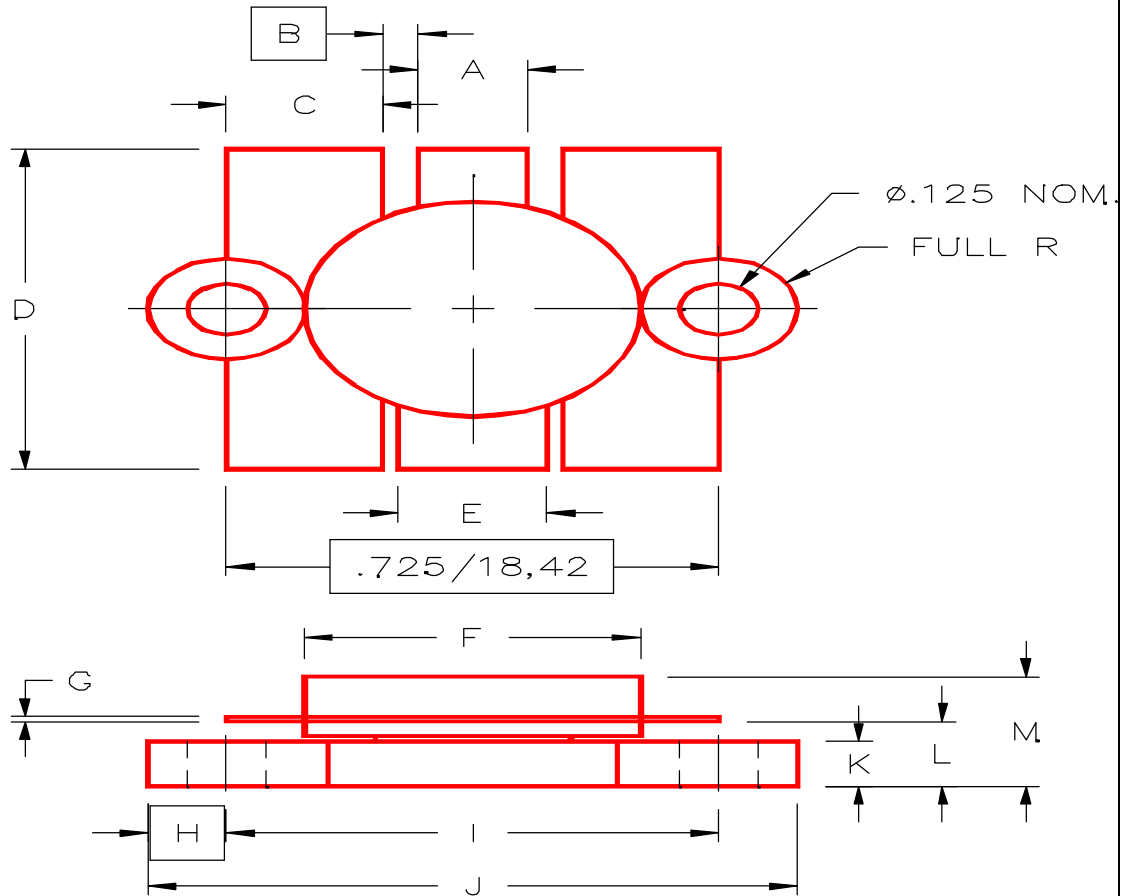

	MINIMUM INCHES/MM	MAXIMUM INCHES/MM		MINIMUM INCHES/MM	MAXIMUM INCHES/MM
A	.150/3,43	.160/4,06	I	.720/18,29	.730/18,54
B	.045/1,14		J	.970/24,64	.980/24,89
C	.210/5,33	.220/5,59	K	.095/2,41	.105/2,67
D	.835/21,21	.865/21,97	L	.150/3,81	.170/4,32
E	.200/5,08	.210/5,33	M		.280/7,11
F	.490/12,45	.510/12,95			
G	.003/0,08	.007/0,18			
H	.125/3,18				