

MS1501

RF & MICROWAVE TRANSISTORS UHF TV/LINEAR APPLICATIONS

Features

- 860 MHz
- P_{OUT} = 2 WATTS
- G_p = 8.5 dB MINIMUM
- GOLD METALLIZATION
- CLASS A LINEAR OPERATION
- COMMON EMITTER CONFIGURATION

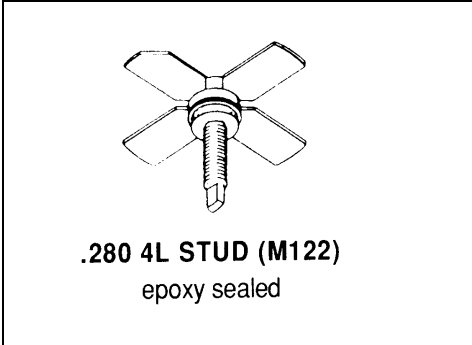

DESCRIPTION:

The MS1501 is a silicon NPN bipolar device specifically designed for high linearity applications in the UHF frequency range including TV Bands IV and V.

Gold metallization and emitter ballasting assure high reliability under Class A linear amplifier operation.

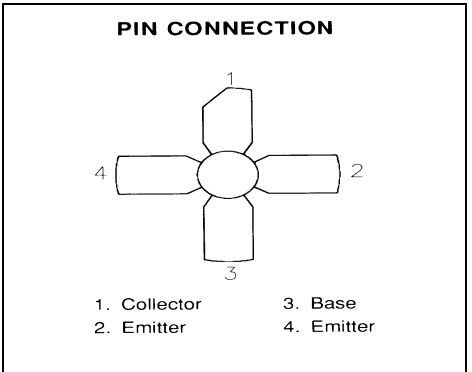

ABSOLUTE MAXIMUM RATINGS (T_{case} = 25°C)

Symbol	Parameter	Value	Unit
V _{CBO}	Collector - Base Voltage	45	V
V _{CEO}	Collector - Emitter Voltage	25	V
V _{EBO}	Emitter - Base Voltage	4	V
I _C	Device Current	800	mA
P _{DISS}	Power Dissipation	15.9	W
T _J	Junction Temperature	+200	°C
T _{stg}	Storage Temperature	-65 to +150	°C

Thermal Data

R _{TH(J-C)}	Junction-case Thermal Resistance	11.0	°C/W
----------------------	----------------------------------	------	------

ELECTRICAL SPECIFICATIONS (T_{case} = 25°C)
STATIC

Symbol	Test Conditions		Value			Unit
			Min.	Typ.	Max.	
BV_{CBO}	I_C = 10 mA	I_E = 0 mA	45	---	---	V
BV_{CEO}	I_C = 80 mA	I_B = 0 mA	25	---	---	V
BV_{EBO}	I_E = 1 mA	I_C = 0 mA	4.0	---	---	V
I_{CBO}	V_{CB} = 28V	I_E = 0 mA	---	---	0.45	mA
H_{FE}	V_{CE} = 20 V	I_C = 250 mA	10	---	100	---

DYNAMIC

Symbol	Test Conditions			Value			Unit
				Min.	Typ.	Max.	
P_{OUT}	f = 860 MHz	V_{CE} = 25V	I_C = 450 mA	2	---	---	W
G_P	f = 860 MHz	V_{CE} = 25V	I_C = 450 mA	8.5	---	---	dB
IMD₃	P_{SYNC} = 2 W	V_{CE} = 25V	I_C = 450 mA	---	-60	---	dBc
C_{OB}	f = 1 MHz	V_{CB} = 25V		---	---	10	pf

Conditions: f₁ = 360 MHz, f₂ = 863.5 MHz, f₃ = 864.5 MHz

PACKAGE MECHANICAL DATA

PACKAGE STYLE M122

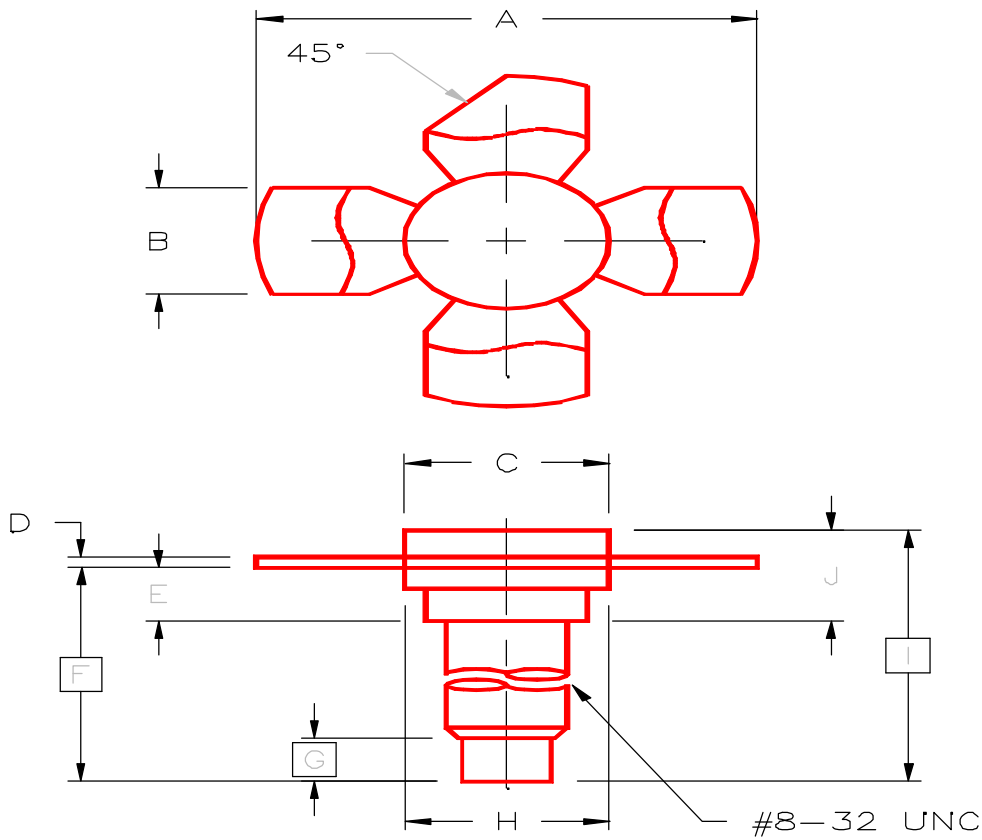

	MINIMUM INCHES/MM	MAXIMUM INCHES/MM		MINIMUM INCHES/MM	MAXIMUM INCHES/MM
A	1.010/25,65	1.055/26,80	I	.640/16,26	
B	.220/5,59	.230/5,84	J	.175/4,45	.217/5,51
C	.270/6,86	.285/7,24			
D	.003/0,08	.007/0,18			
E	.117/2,97	.137/3,48			
F	.572/14,53				
G	.130/3,30				
H	.275/6,99	.285/7,24			