

MS1581

**RF & MICROWAVE TRANSISTORS
UHF TV/LINEAR APPLICATIONS**

Features

- 860 MHz
- 25 VOLTS
- P_{OUT} = 4.0 WATTS
- G_P = 7.0 dB MINIMUM
- GOLD METALLIZATION
- COMMON EMITTER CONFIGURATION

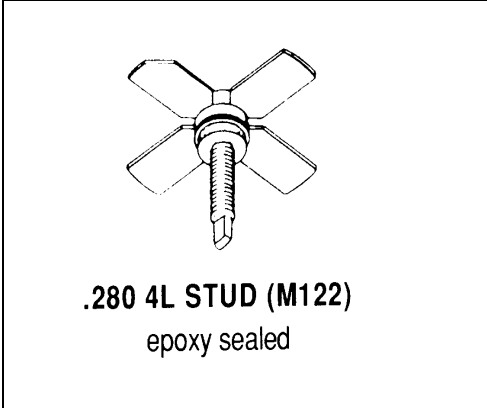

DESCRIPTION:

The MS1581 is a silicon NPN bipolar transistor specifically designed for high linearity UHF TV driver applications. Gold metallization and emitter ballasting assure high reliability under Class A linear operation.

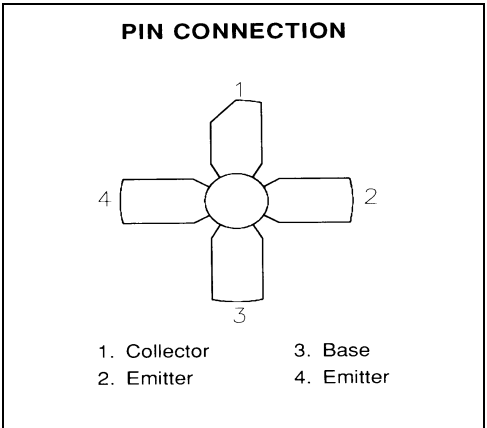

ABSOLUTE MAXIMUM RATINGS (T_{case} = 25°C)

Symbol	Parameter	Value	Unit
V _{CBO}	Collector-Base Voltage	45	V
V _{CEO}	Collector-Emitter Voltage	25	V
V _{EBO}	Emitter-Base Voltage	4	V
P _{DISS}	Power Dissipation	31.8	W
I _C	Device Current	1.6	A
T _J	Junction Temperature	+200	°C
T _{STG}	Storage Temperature	-65 to +150	°C

Thermal Data

R _{TH(J-C)}	Thermal Resistance Junction-case	5.5	°C/W
----------------------	----------------------------------	-----	------

ELECTRICAL SPECIFICATIONS (T_{case} = 25°C)
STATIC

Symbol	Test Conditions		Value			Unit
			Min.	Typ.	Max.	
BV_{CBO}	I_C = 10 mA	I_E = 0 mA	45	---	---	V
BV_{CEO}	I_C = 20 mA	I_E = 0 mA	25	---	---	V
BV_{EBO}	I_E = 2.5 mA	I_E = 0 mA	3.0	---	---	V
I_{CBO}	V_{CB} = 28 V	I_E = 0 mA	---	---	0.9	mA
HFE	V_{CE} = 20 V	I_C = 500 mA	10	---	200	---

DYNAMIC

Symbol	Test Conditions			Value			Unit
				Min.	Typ.	Max.	
P_{OUT}	f = 860 MHz	P_{IN} = 8 W	V_{CE} = 25 V	4.0	---	---	W
G_P	f = 860 MHz	P_{IN} = 8 W	V_{CE} = 25 V	7.0	---	---	dB
IMD₃	P_{SYNC} = 4 W	P_{IN} = 8 W	V_{CE} = 25 V	---		-60	dBc
C_{OB}	f = 1 MHz	V_{CB} = 25 V		---	---	20	pf

Conditions: **V_{CE} = 25 V** **I_C = 850 mA**

PACKAGE MECHANICAL DATA

