

SD1485

RF & MICROWAVE TRANSISTORS TV/LINEAR APPLICATIONS

Features

- 170 - 230 MHz
- 32 VOLTS
- P_{OUT} = 200 WATTS
- G_P = 11.0 dB GAIN MINIMUM
- INTERNAL INPUT MATCHING
- COMMON EMITTER CONFIGURATION

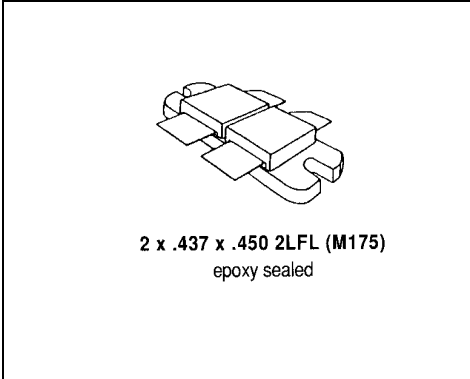

DESCRIPTION:

The SD1485 is a gold metallized epitaxial silicon NPN planar transistor using diffused emitter ballast resistors for high linearity Class AB operation in VHF and Band III television transmitters and transposers.

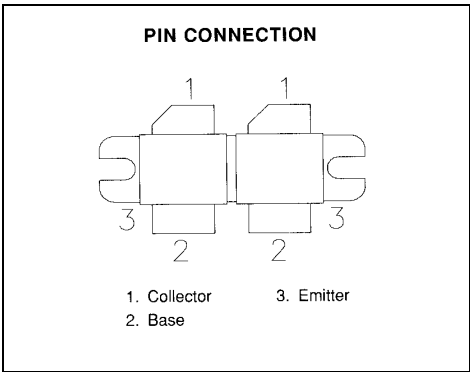

ABSOLUTE MAXIMUM RATINGS (T_{case} = 25°C)

Symbol	Parameter	Value	Unit
V _{CBO}	Collector-Base Voltage	65	V
V _{CEO}	Collector-Emitter Voltage	35	V
V _{EBO}	Emitter-Base Voltage	3.0	V
I _C	Device Current	25	A
P _{DISS}	Power Dissipation	385	W
T _J	Junction Temperature	200	°C
T _{STG}	Storage Temperature	-65 to +150	°C

Thermal Data

R _{TH(J-C)}	Thermal Resistance Junction-case	0.45	°C/W
----------------------	----------------------------------	------	------

ELECTRICAL SPECIFICATIONS (T_{case} = 25°C)

STATIC

Symbol	Test Conditions		Value			Unit
			Min.	Typ.	Max.	
BV _{CBO}	I _C = 100 mA	I _E = 0 mA	65	---	---	V
BV _{CER}	I _C = 100 mA	R _{BE} = 15 Ω	60	---	---	V
BV _{CEO}	I _C = 100 mA	I _B = 0 mA	35	---	---	V
BV _{EBO}	I _E = 20 mA	I _C = 0 mA	3.0	---	---	V
I _{CES}	V _{CE} = 32 V	I _E = 0 mA	---	---	10	mA
HFE	V _{CE} = 5 V	I _C = 4 A	20	---	70	---

DYNAMIC

Symbol	Test Conditions			Value			Unit
				Min.	Typ.	Max.	
P _{OUT}	f = 230 MHz	V _{CE} = 32 V	I _{CQ} = 2 x 500 mA	200	---	---	W
G _p	f = 230 MHz	V _{CE} = 32 V	I _{CQ} = 2 x 500 mA	11	---	---	dB
η _c	f = 230 MHz	V _{CE} = 32 V	I _{CQ} = 2 x 500 mA	50	---	---	%
C _{OB}	f = 1 MHz	V _{CB} = 28 V		---	---	190	pF

IMPEDANCE DATA

FREQ	Z _{IN} (Ω)	Z _{CL} (Ω)
170 MHz	2.7 + j1.0	3.7 + j3.0
200 MHz	2.1 + j1.5	3.4 + j3.7
230 MHz	1.4 + j2.2	3.0 + j4.1

P_{OUT} = 200W

V_{CC} = 32V

TYPICAL PERFORMANCE

POWER OUTPUT vs POWER INPUT

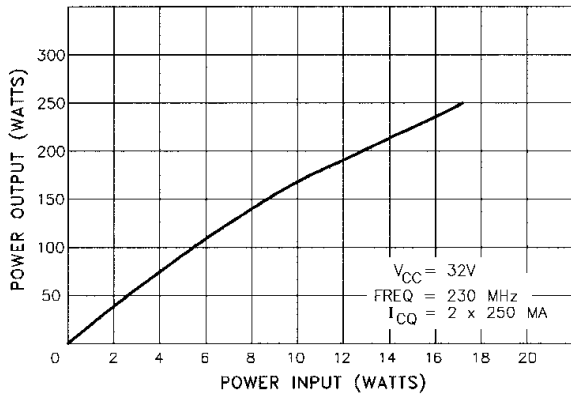

BRAODBAND POWER GAIN vs FREQUENCY

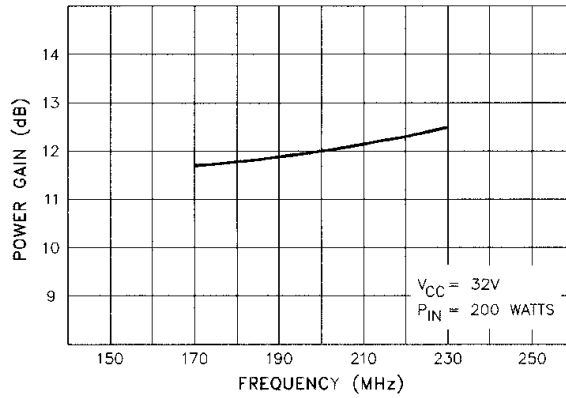

THERMAL RESISTANCE vs CASE TEMPERATURE

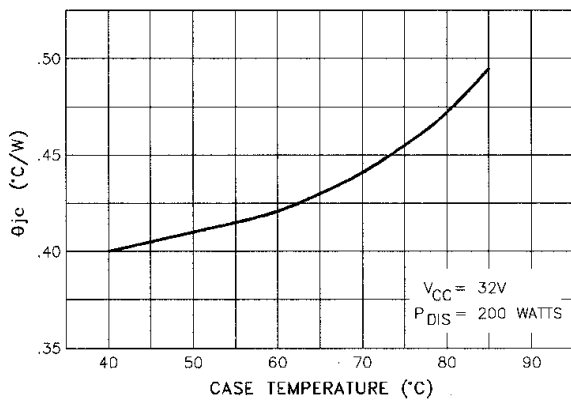

COLLECTOR EFFICIENCY vs FREQUENCY

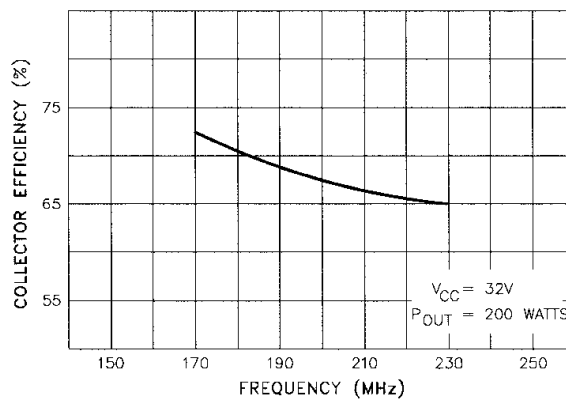

PACKAGE MECHANICAL DATA

PACKAGE STYLE M175

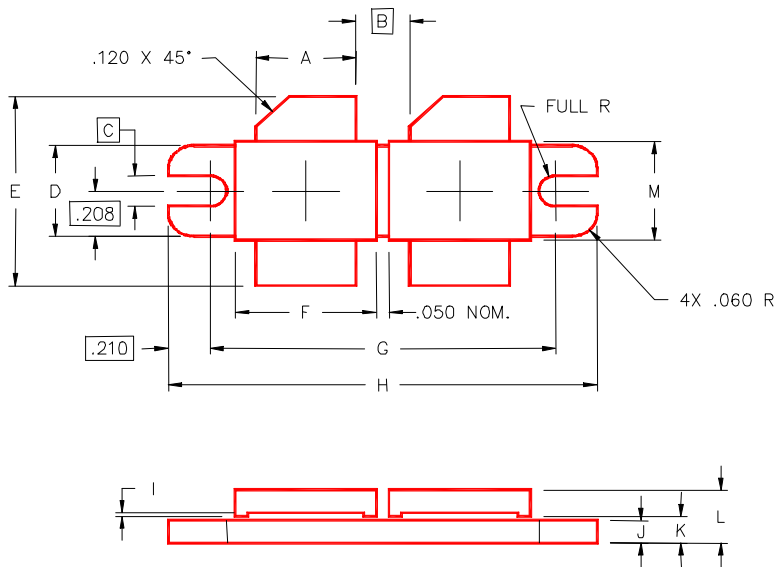

	MINIMUM INCHES/MM	MAXIMUM INCHES/MM		MINIMUM INCHES/MM	MAXIMUM INCHES/MM
A	.373/9,47	.385/9,78	I	.002/0,05	.006/0,15
B	.190/4,83		J	.095/2,41	.105/2,67
C	.125/3,18		K	.115/2,92	.135/3,43
D	.411/10,44	.421/10,69	L	.250/6,35	
E	.825/20,96	.865/21,97	M	.445/11,30	.455/11,56
F	.525/13,34	.535/13,59			
G	1.255/31,88	1.265/32,13			
H	1.675/42,55	1.685/42,80			