

SD1429-03
**RF & MICROWAVE TRANSISTORS
UHF MOBILE APPLICATIONS**
Features

- 470 MHz
- 12.5 VOLTS
- P_{OUT} = 15.0 WATTS
- G_p = 7.5 dB MINIMUM
- COMMON EMITTER CONFIGURATION

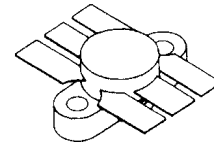

.500 6LFL (M111)
epoxy sealed

DESCRIPTION:

The SD1429-03 is a 12.5V epitaxial silicon NPN planar transistor designed primarily for UHF communications. It withstands infinite VSWR at rated operating conditions.

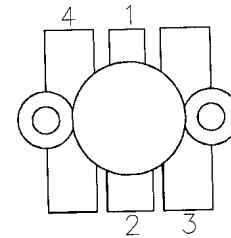
PIN CONNECTION

- | | |
|--------------|------------|
| 1. Collector | 3. Emitter |
| 2. Base | 4. Emitter |

ABSOLUTE MAXIMUM RATINGS (T_{case} = 25°C)

Symbol	Parameter	Value	Unit
V _{CBO}	Collector-Base Voltage	36	V
V _{CEO}	Collector-Emitter Voltage	16	V
V _{CES}	Collector-Emitter Voltage	36	V
V _{EBO}	Emitter-Base Voltage	4.0	V
I _C	Collector Current	3.4	W
P _{tot}	Total Power Dissipation	37.5	A
T _J	Junction Temperature	+200	°C
T _{STG}	Storage Temperature	-65 to +150	°C

Thermal Data

R _{TH(J-C)}	Thermal Resistance Junction-case	4.6	°C/W
----------------------	----------------------------------	-----	------

ELECTRICAL SPECIFICATIONS (T_{case} = 25°C)

STATIC

Symbol	Test Conditions		Value			Unit
			Min.	Typ.	Max.	
BV_{CES}	I_C = 50 mA	V_{BE} = 0 mA	36	---	---	V
BV_{CEO}	I_C = 50 mA	I_B = 0 V	16	---	---	V
BV_{EBO}	I_C = 10 mA	I_C = 0 mA	4.0	---	---	V
I_{CES}	V_{CE} = 15 V	V_{BE} = 0 mA	---	---	5	mA
HFE	V_{CE} = 5.0 V	I_C = 500 A	20	---	200	---

DYNAMIC

Symbol	Test Conditions			Value			Unit
				Min.	Typ.	Max.	
P_{OUT}	f = 470 MHz	P_{IN} = 2.65 W	V_{CE} = 12.5 V	15	---	---	W
G_p	f = 470 MHz	P_{IN} = 2.65 W	V_{CE} = 12.5 V	7.5	---	---	dB
C_{OB}	f = 1 MHz	V_{CB} = 12.0 V		---	---	50.0	pf

IMPEDANCE DATA

FREQ	Z _{IN} (Ω)	Z _{CL} (Ω)
450 MHz	2.9 - j 0.2	1.0 + j 1.9
470 MHz	2.4 - j 0.9	0.90 + j 2.3
512 MHz	0.3 + j 0.4	0.90 + j 2.3

P_{OUT} = 15 W

V_{CE} = 12.5V

PACKAGE MECHANICAL DATA

PACKAGE STYLE M111

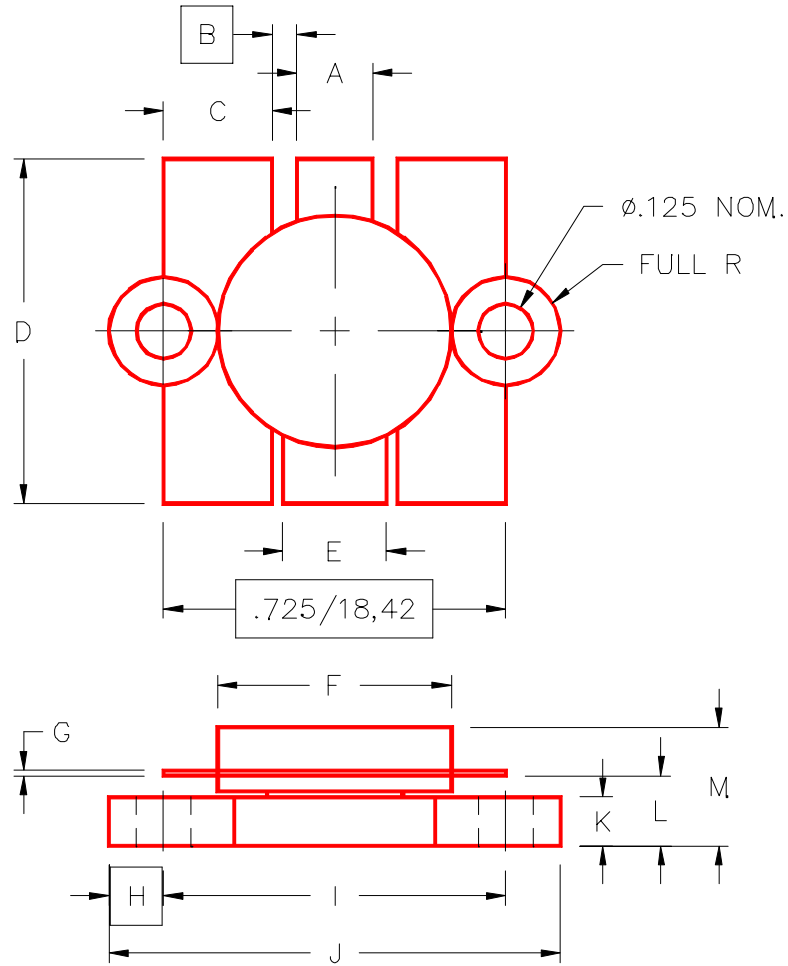

	MINIMUM INCHES/MM	MAXIMUM INCHES/MM		MINIMUM INCHES/MM	MAXIMUM INCHES/MM
A	.150/3,43	.160/4,06	I	.720/18,29	.730/18,54
B	.045/1,14		J	.970/24,64	.980/24,89
C	.210/5,33	.220/5,59	K	.095/2,41	.105/2,67
D	.835/21,21	.865/21,97	L	.150/3,81	.170/4,32
E	.200/5,08	.210/5,33	M		.280/7,11
F	.490/12,45	.510/12,95			
G	.003/0,08	.007/0,18			
H	.125/3,18				