

# MS1455

## RF & MICROWAVE TRANSISTORS 800 - 900 MHz APPLICATIONS

### Features

- 836 MHz
- 12.5 VOLTS
- $P_{OUT} = 45$  WATTS
- $G_P = 4.7$  dB MINIMUM
- COMMON BASE CONFIGURATION

### DESCRIPTION:

The MS1455 is a 12.5 V Class C epitaxial silicon NPN planar transistor designed for amplifier applications in the 806-866 MHz frequency range. Internal impedance matching assures optimum gain and efficiency across the entire frequency band. Gold metalization and emitter ballast resistors assures infinite VSWR capability and long term reliability.

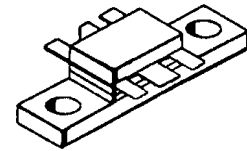

.230 6LFL (M142)  
epoxy sealed

### PIN CONNECTION

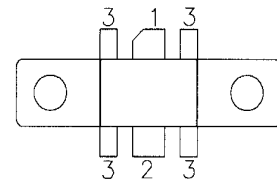

1. Collector      3. Base  
2. Emitter

### ABSOLUTE MAXIMUM RATINGS (T<sub>case</sub> = 25°C)

Symbol	Parameter	Value	Unit
$V_{CBO}$	Collector-Base Voltage	36	V
$V_{EBO}$	Emitter-Base Voltage	4.0	V
$V_{CEO}$	Collector-Emitter Voltage	18	V
$V_{CES}$	Collector-Emitter Voltage	36	V
$P_{DISS}$	Power Dissipation	150	W
$I_C$	Device Current	9.0	A
$T_J$	Junction Temperature	200	°C
$T_{STG}$	Storage Temperature	-65 to +150	°C

### Thermal Data

$R_{TH(J-C)}$	Thermal Resistance Junction-case	1.2	°C/W
---------------	----------------------------------	-----	------

**ELECTRICAL SPECIFICATIONS (T<sub>case</sub> = 25°C)**
**STATIC**

Symbol	Test Conditions			Value			Unit
				Min.	Typ.	Max.	
BV <sub>CES</sub>	I <sub>C</sub> = 50 mA	V <sub>BE</sub> = 0 V		36	---	---	V
BV <sub>CEO</sub>	I <sub>C</sub> = 50 mA	I <sub>B</sub> = 0 mA		18	---	---	V
BV <sub>EBO</sub>	I <sub>E</sub> = 10 mA	I <sub>C</sub> = 0 mA		4.0	---	---	V
I <sub>CBO</sub>	V <sub>CB</sub> = 15 V	I <sub>E</sub> = 0 mA		---	---	5	mA
HFE	V <sub>CE</sub> = 5 V	I <sub>C</sub> = 1 A		5	---	200	---

**DYNAMIC**

Symbol	Test Conditions			Value			Unit
				Min.	Typ.	Max.	
P <sub>OUT</sub>	f = 836 MHz	P <sub>IN</sub> = 15W	V <sub>CE</sub> = 12.5V	45	---	---	W
G <sub>P</sub>	f = 836 MHz	P <sub>IN</sub> = 15W	V <sub>CE</sub> = 12.5V	4.7	---	---	dB
C <sub>OB</sub>	f = 1 MHz	V <sub>CB</sub> = 12.5 V		---	---	105	pf

**IMPEDANCE DATA**

FREQ	Z <sub>IN</sub> (Ω)	Z <sub>CL</sub> (Ω)
806 MHz	1.4 – j4.6	1.0 – j1.5
836 MHz	2.0 – j5.2	0.95 – j1.7
866 MHz	2.3 – j5.3	0.75 – j1.7

P<sub>IN</sub> = 15W  
V<sub>CE</sub> = 12.5V

**TEST CURCUIT**

**MS1455**

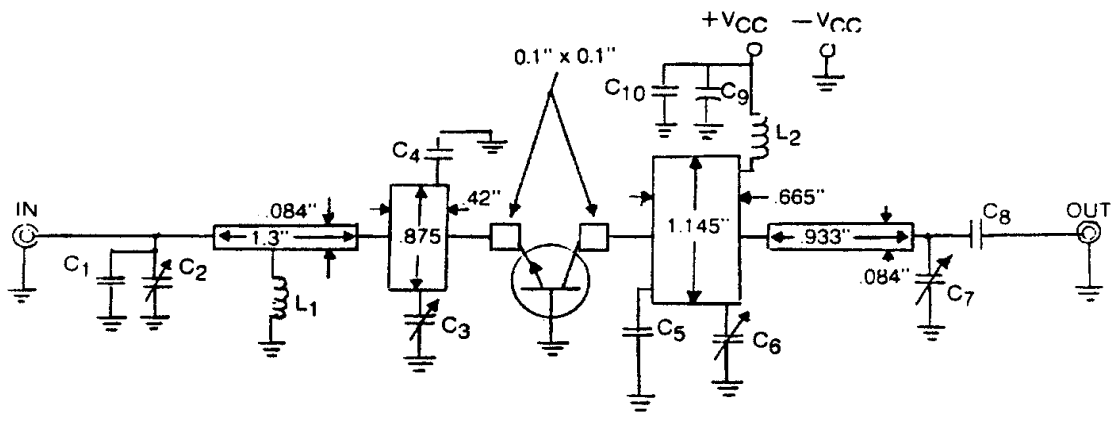
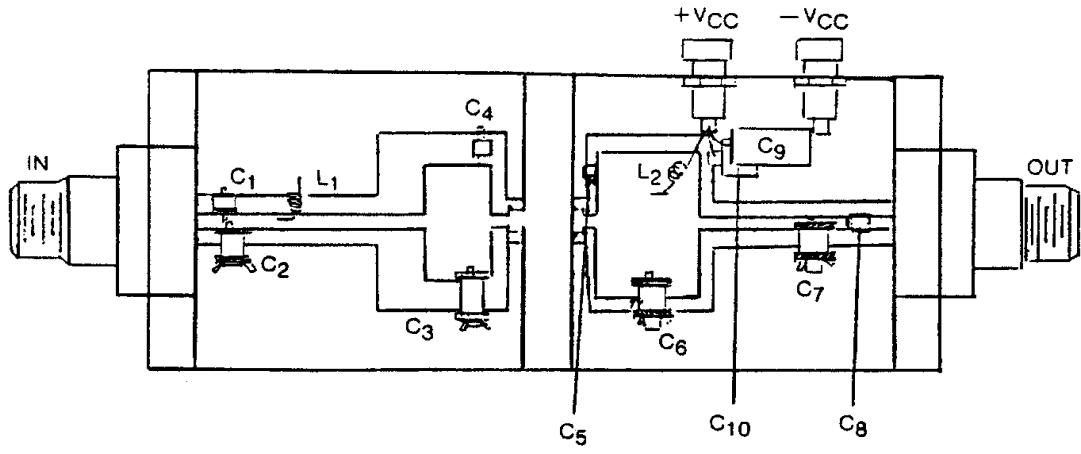

- C1, C4 : 5pF ATC 100 mils Chip Capacitor
- C2 : 1 - 12pF Variable Capacitor
- C3 : .6 - 6pF Variable Capacitor
- C5 : 2pF "A" Size Chip Capacitor
- C6, C7 : .6 - 12pF Voltronic Variable Capacitor

- C8 : 480pF ATC 100 mils Chip Capacitor
- C9 : 47 $\mu$ F, 63V, Electrolytic Capacitor
- C10 : 1000pF Unelco Capacitor
- L1, L2 : 5 Turns #24 AWG Enamel

Board Material: 3M-K-6098-11 12.9 mils Thick

**PACKAGE MECHANICAL DATA**

PACKAGE STYLE M142

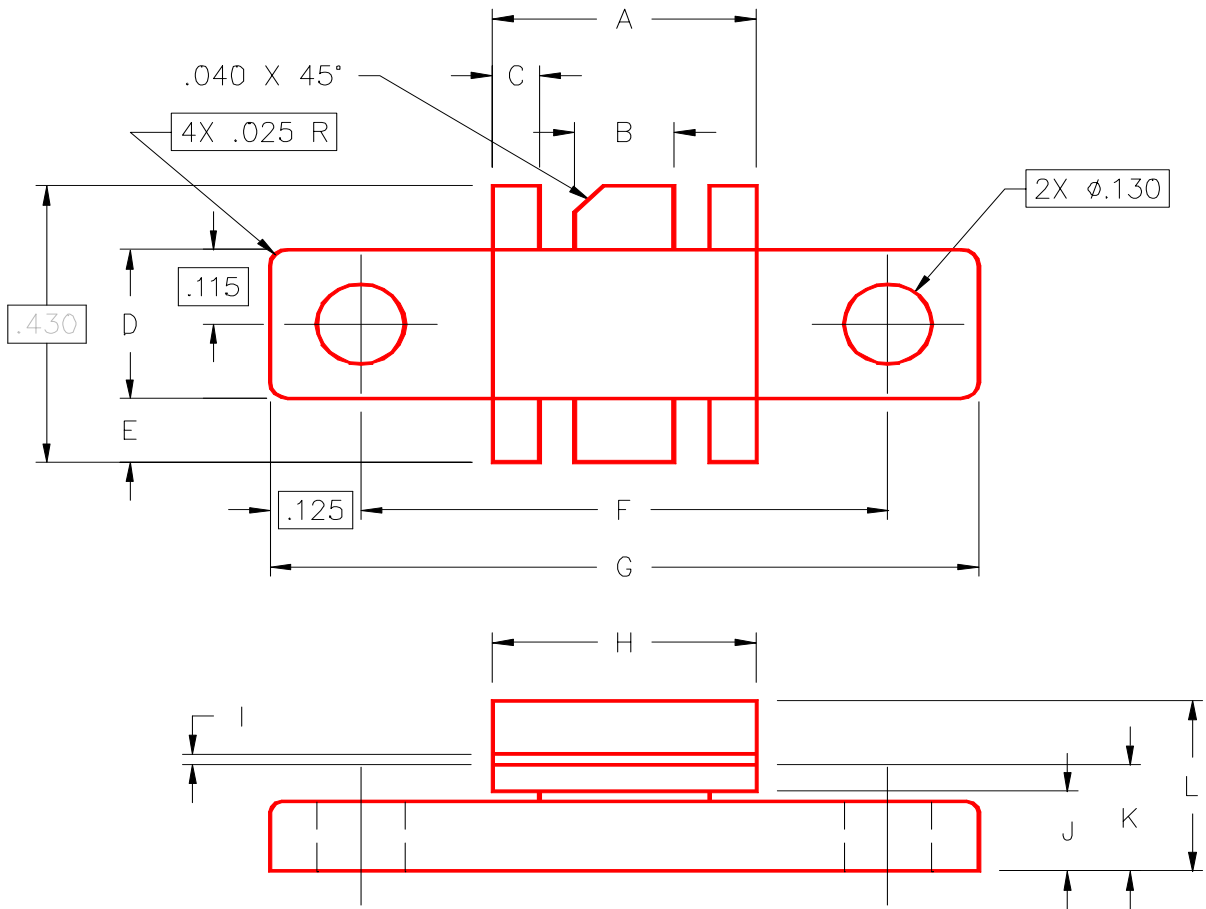

	MINIMUM INCHES/MM	MAXIMUM INCHES/MM		MINIMUM INCHES/MM	MAXIMUM INCHES/MM
A	.355/9,02	.365/9,27	I	.004/0,10	.006/0,15
B	.115/2,92	.125/3,18	J	.120/3,05	.130/3,30
C	.075/1,91	.085/2,16	K	.160/4,06	.180/4,57
D	.225/5,72	.235/5,97	L	.230/5,84	.260/6,60
E	.090/2,29	.110/2,79			
F	.720/18,29	.730/18,54			
G	.970/24,64	.980/24,89			
H	.355/9,02	.365/9,27			