

# MS1263

## RF & MICROWAVE TRANSISTOR UHF MOBILE APPLICATIONS

### Features

- 512 MHz
- 12.5 VOLTS
- $P_{OUT} = 15\text{ W MINIMUM}$
- $G_p = 7.8\text{ dB}$
- INPUT MATCHED
- COMMON EMITTER CONFIGURATION

### DESCRIPTION:

The MS1263 is a NPN silicon RF power transistor designed for 12.5-volt UHF amplifier applications operating to 512 MHz. The MS1263 has internal impedance matching for broadband operation and diffused emitter ballast for high load VSWR tolerance.

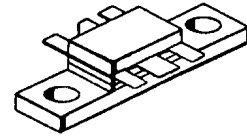

.230 6LFL (M142)  
epoxy sealed

### PIN CONNECTION

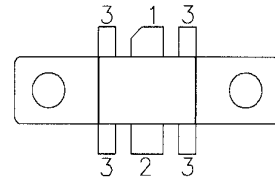

1. Collector      3. Base  
2. Emitter

### ABSOLUTE MAXIMUM RATINGS ( $T_{case} = 25^{\circ}\text{C}$ )

Symbol	Parameter	Value	Unit
$V_{CBO}$	Collector-Base Voltage	36	V
$V_{CEO}$	Collector-Emitter Voltage	16	V
$V_{EBO}$	Emitter-Base Voltage	4.0	V
$I_C$	Collector Current	3.4	A
$P_{TOT}$	Total Power Dissipation	37.5	W
$T_{STG}$	Storage Temperature	-65 to +150	$^{\circ}\text{C}$
$T_J$	Junction Temperature	+200	$^{\circ}\text{C}$

### Thermal Data

$R_{\theta JC}$	Thermal Resistance Junction-case	4.6	$^{\circ}\text{C/W}$
-----------------	----------------------------------	-----	----------------------

**ELECTRICAL SPECIFICATIONS (T<sub>case</sub> = 25°C)**
**STATIC**

Symbol	Test Conditions		Value			Unit
			Min.	Typ.	Max.	
<b>BV<sub>CEO</sub></b>	<b>I<sub>C</sub> = 50mA</b>	<b>I<sub>B</sub> = 0</b>	<b>16</b>	---	---	<b>V</b>
<b>BV<sub>CES</sub></b>	<b>I<sub>C</sub> = 50mA</b>	<b>V<sub>BE</sub> = 0</b>	<b>36</b>	---	---	<b>V</b>
<b>BV<sub>EBO</sub></b>	<b>I<sub>E</sub> = 5.0mA</b>	<b>I<sub>C</sub> = 0</b>	<b>4.0</b>	---	---	<b>V</b>
<b>I<sub>CES</sub></b>	<b>V<sub>CE</sub> = 15V</b>	<b>V<sub>BE</sub> = 0</b>	---	---	<b>5.0</b>	<b>mA</b>
<b>H<sub>FE</sub></b>	<b>V<sub>CE</sub> = 5.0V</b>	<b>I<sub>C</sub> = 500mA</b>	<b>20</b>	---	<b>120</b>	---

**DYNAMIC**

Symbol	Test Conditions			Value			Unit
				Min.	Typ.	Max.	
<b>P<sub>OUT</sub></b>	<b>f = 512 MHz</b>	<b>P<sub>IN</sub> = 2.5 W</b>	<b>V<sub>CC</sub> = 12.5V</b>	<b>15</b>	---	---	<b>W</b>
<b>G<sub>P</sub></b>	<b>f = 512 MHz</b>	<b>P<sub>IN</sub> = 2.5 W</b>	<b>V<sub>CC</sub> = 12.5V</b>	<b>7.8</b>	---	---	<b>dB</b>
<b>η<sub>c</sub></b>	<b>f = 512 MHz</b>	<b>P<sub>IN</sub> = 2.5 W</b>	<b>V<sub>CC</sub> = 12.5V</b>	<b>50</b>	---	---	<b>%</b>
<b>C<sub>OB</sub></b>	<b>f = 1.0 MHz</b>	<b>V<sub>CB</sub> = 12.5V</b>		---	---	<b>50</b>	<b>pf</b>

**IMPEDANCE DATA**

FREQ	Z <sub>IN</sub> (Ω)	Z <sub>CL</sub> (Ω)
<b>470 MHz</b>	<b>0.95 – j1.1</b>	<b>2.2 + j0.9</b>
<b>512 MHz</b>	<b>0.82 + j2.5</b>	<b>2.1 + j2.3</b>

**P<sub>IN</sub> = 2.5W**  
**V<sub>CE</sub> = 12.5V**

**PACKAGE MECHANICAL DATA**

**PACKAGE STYLE M142**

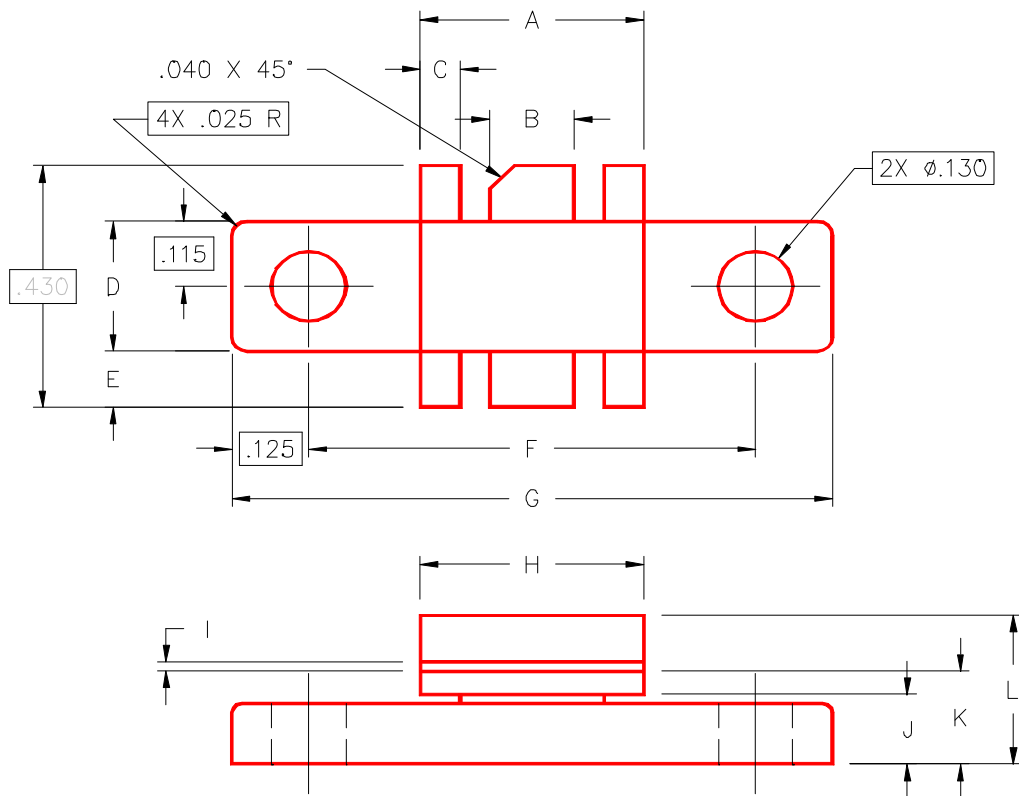

	MINIMUM INCHES/MM	MAXIMUM INCHES/MM		MINIMUM INCHES/MM	MAXIMUM INCHES/MM
A	.355/9,02	.365/9,27	I	.004/0,10	.006/0,15
B	.115/2,92	.125/3,18	J	.120/3,05	.130/3,30
C	.075/1,91	.085/2,16	K	.160/4,06	.180/4,57
D	.225/5,72	.235/5,97	L	.230/5,84	.260/6,60
E	.090/2,29	.110/2,79			
F	.720/18,29	.730/18,54			
G	.970/24,64	.980/24,89			
H	.355/9,02	.365/9,27			