

2N6255

**RF & MICROWAVE DISCRETE
LOW POWER TRANSISTORS**

Features

- Silicon NPN, To-39 packaged VHF Transistor
- 3.0 Watt Power Output @ 175 MHz
- Power Gain, $G_{PE} = 7.8$ dB
- Efficiency = 50%

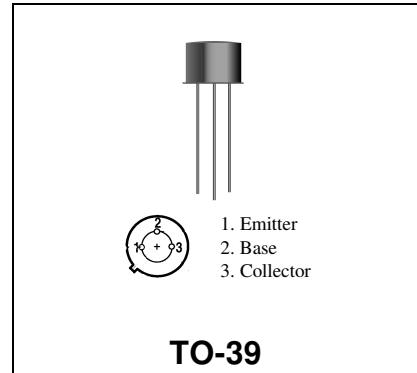

DESCRIPTION:

The 2N6255 is a silicon NPN transistor, designed for 12.5 volt VHF equipment. Applications include amplifier, pre-driver, driver, and output stages. It is also suitable for oscillator and frequency-multiplier functions.

ABSOLUTE MAXIMUM RATINGS (T_{case} = 25°C)

Symbol	Parameter	Value	Unit
V _{CEO}	Collector-Emitter	18	Vdc
V _{CBO}	Collector-Base Voltage	36	Vdc
V _{EBO}	Emitter-Base Voltage	4.0	Vdc
I _c	Collector Current	1	A

Thermal Data

P _D	Total Device Dissipation @ T _A = 25°C Derate above 25°C	5.0 28.5	Watts mW/ °C
----------------	---	-------------	-----------------

ELECTRICAL SPECIFICATIONS (T_{case} = 25°C)
**STATIC
(off)**

Symbol	Test Conditions	Value			Unit
		Min.	Typ.	Max.	
BV _{CES}	Collector-Emitter Breakdown Voltage (I _C = 5.0 mA _{dc} , V _{BE} = 0V _{dc})	36	-	-	V _{dc}
BV _{CEO}	Collector-Emitter Breakdown Voltage (I _C = 10 mA _{dc} , I _B = 0)	18	-	-	V _{dc}
BV _{EBO}	Emitter-Base Breakdown Voltage (I _E = 1.0 mA _{dc} , I _C = 0)	4.0	-	-	V _{dc}
I _{CES}	Collector Cutoff Current (V _{CE} = 15 V _{dc} , V _{BE} = 0 V _{dc})	-	-	5.0	mA
I _{CBO}	Emitter Cutoff Current (V _{CB} = 15 V _{dc} , I _E = 0)	-	-	.25	mA

(on)

HFE	DC Current Gain (I _C = 250 mA _{dc} , V _{CE} = 5.0 V _{dc})	5.0	-	-	-
-----	---	-----	---	---	---

DYNAMIC

Symbol	Test Conditions	Value			Unit
COB	Output Capacitance (V _{CB} = 12.5V _{dc} , f = 1.0 MHz)	-	15	20	pF

FUNCTIONAL

Symbol	Test Conditions	Value			Unit	
		Min.	Typ.	Max.		
G _{PE}	Power Gain	Test Circuit-Figure 1 P _{out} = 3.0 W, V _{CC} = 12.5V _{dc} f = 175 MHz	7.8	-	-	dB
η _C	Collector Efficiency	Test Circuit-Figure 1 P _{out} = 3.0 W, V _{CC} = 12.5V _{dc} f = 175 MHz	50	-	-	%

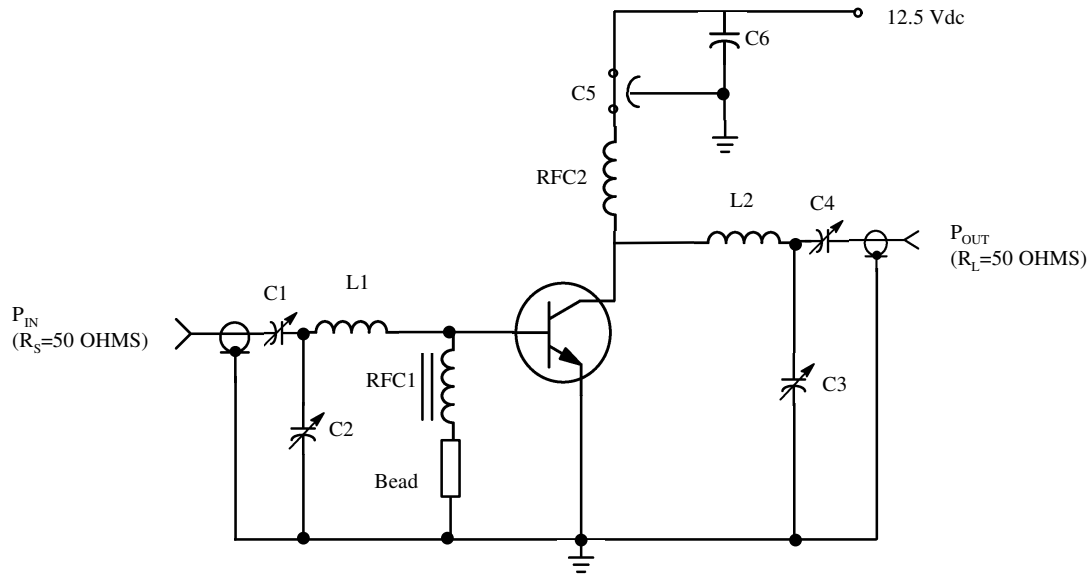

**Figure 1 - 175 MHz RF AMPLIFIER CIRCUIT FOR G_{PE} ,
AND EFFICIENCY SPECIFICATIONS.**

C1,3: 2.0-50 pF ARCO 461 ELEMENCO
C5: 1000 pF FEED THRU
L1: 1 TURN #18 AWG ¼" I.D.
RFC2: 0.15 uH MOLDED CHOKE

C2,4: 5.0-80 pF ARCO 462 ELEMENCO
C6: 5.0 uF
L2: 2 1/2 TURNS #18 AWG ¼" I.D.
BEAD: FERROXCUBE 56-570-65/3B

RFC1: 0.15 uH MOLDED CHOKE WITH BEAD ON GROUND LEG

PACKAGE STYLE M246

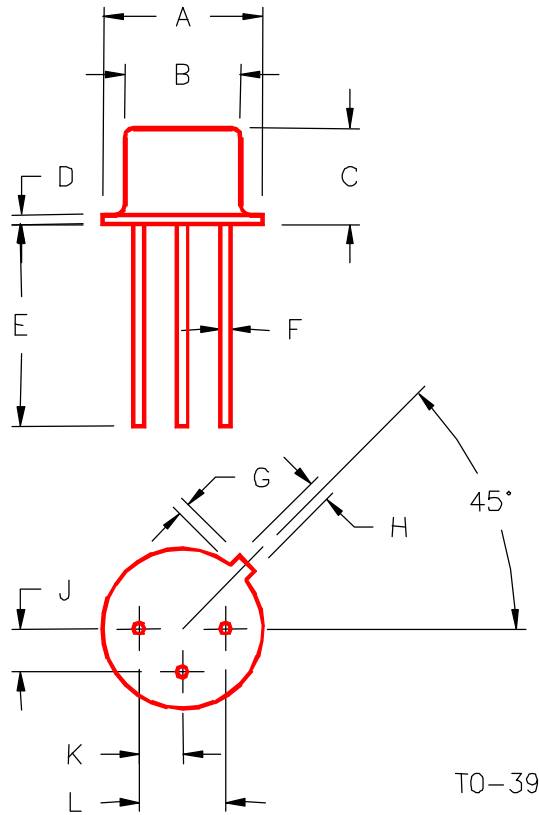

TO-39

	MINIMUM INCHES/MM	MAXIMUM INCHES/MM		MINIMUM INCHES/MM	MAXIMUM INCHES/MM
A	.350/8,89	.370/9,40	J	.095/2,41	.105/2,67
B	.315/8,00	.335/8,51	K	.095/2,41	.105/2,67
C	.240/6,10	.260/6,60	L	.190/4,83	.210/5,33
D	.015/0,38	.045/1,14			
E	.500/12,70				
F	.016/0,41	.019/0,48			
G	.029/0,74	.040/1,02			
H	.028/0,71	.034/0,86			