

# RECTIFIERS

## High Efficiency, 1A

UES1001-UES1003

2

### FEATURES

- Very Fast Recovery Times
- Very Low Forward Voltage
- Small Size
- Convenient Package

### DESCRIPTION

An axial leaded power rectifier useful in many switching applications. Particularly suited where very fast recovery and low forward voltage are required.

### ABSOLUTE MAXIMUM RATINGS

Peak Inverse Voltage, UES1001 .....	50V
Peak Inverse Voltage, UES1002 .....	100V
Peak Inverse Voltage, UES1003 .....	150V
Maximum Average D.C. Output Current at $T_L = 75^\circ\text{C}$ , $L = 3/8"$ .....	1A
Non-Repetitive Surge Current at 8.3ms .....	30A
Thermal Resistance at $L = 3/8"$ .....	$75^\circ\text{C/W}$
Operating and Storage Temperature Range .....	$-55^\circ\text{C} + 175^\circ\text{C}$

### ELECTRICAL SPECIFICATIONS

Type	PIV	Maximum Forward Voltage ( $V_F$ ) @		Maximum Reverse Current ( $I_R$ ) @ PIV		Maximum Reverse Recovery Time*
		$T_J = 25^\circ\text{C}$	$T_J = 100^\circ\text{C}$	@ $T_J = 25^\circ\text{C}$	@ $T_J = 100^\circ\text{C}$	
UES1001	50V	.975V	.895V	2 $\mu\text{A}$	50 $\mu\text{A}$	25nS
UES1002	100V	@	@			
UES1003	150V	1A	1A			

\*Measured in circuit  $I_F = .5\text{A}$ ,  $I_R = 1.0\text{A}$ ,  $I_{REC} = .25\text{A}$

### MECHANICAL SPECIFICATIONS

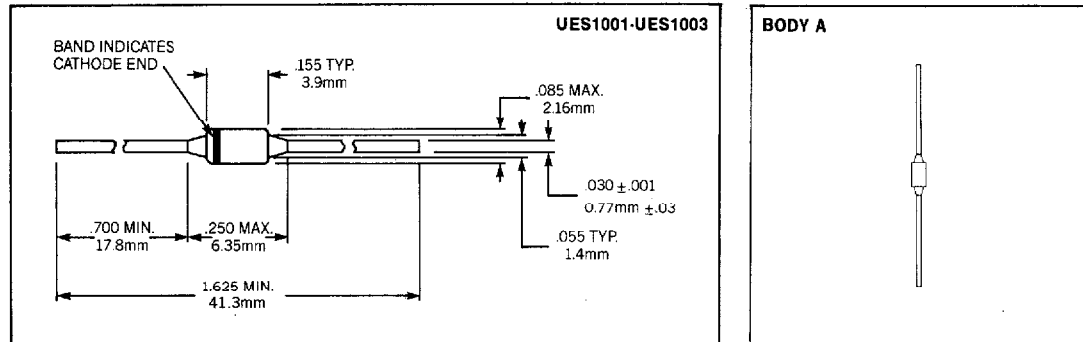

THESE DEVICES ALSO AVAILABLE IN SURFACE MOUNT PACKAGE. SEE SECTION 10

**Output Current vs. Lead Temperature**

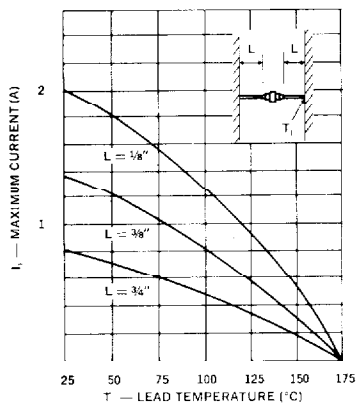

**Typical Forward Current vs. Forward Voltage**

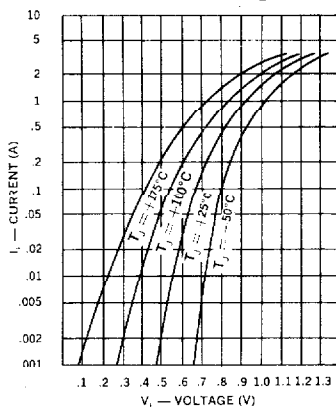

**Typical Reverse Current vs. Voltage**

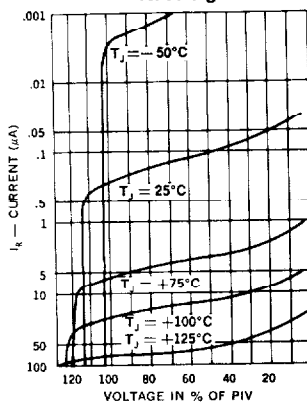

**Peak Output Current vs. Lead Temperature**

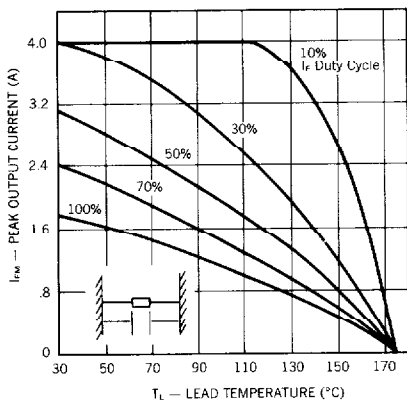

**Forward Pulse Current vs. Duration**

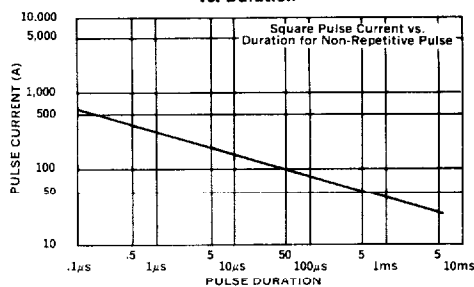

**Multiple Surge Current vs. Duration**

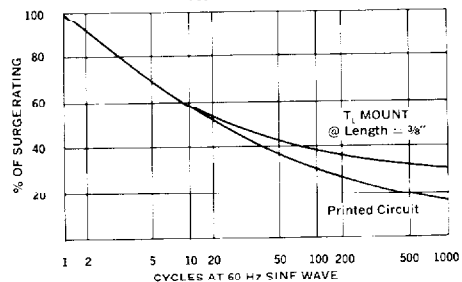

**Reverse-Recovery Circuit**

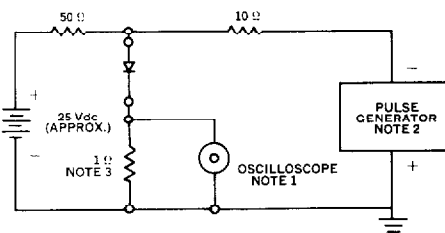

**NOTES:**

1. Oscilloscope: Rise time <math>\leq 3\text{ns}</math>; input impedance =  $50\Omega$ .
2. Pulse Generator: Rise time <math>\leq 8\text{ns}</math>; source impedance  $10\Omega$ .
3. Current viewing resistor, non-inductive, coaxial recommended.