

RADIATION HARDENED N-CHANNEL MOSFET

Reference MIL-PRF-19500/601

DEVICES

2N7261 2N7261U

LEVELS

**JANSR (100K RAD(Si))
 JANSF (300K RAD(Si))**

ABSOLUTE MAXIMUM RATINGS ($T_C = +25^\circ\text{C}$ unless otherwise noted)

Parameters / Test Conditions	Symbol	Value	Unit
Drain – Source Voltage	V_{DS}	100	Vdc
Gate – Source Voltage	V_{GS}	± 20	Vdc
Continuous Drain Current $T_C = +25^\circ\text{C}$	I_{D1}	8.0	Adc
Continuous Drain Current $T_C = +100^\circ\text{C}$	I_{D2}	5.0	Adc
Max. Power Dissipation	P_{tl}	25 ⁽¹⁾	W
Drain to Source On State Resistance	$R_{ds(on)}$	0.180 ⁽²⁾	Ω
Operating & Storage Temperature	T_{op}, T_{stg}	-55 to +150	$^\circ\text{C}$

Note: (1) Derated Linearly by 0.2 W/ $^\circ\text{C}$ for $T_C > +25^\circ\text{C}$
 (2) $V_{GS} = 12\text{Vdc}$, $I_D = 5.0\text{A}$

PRE-IRRADIATION ELECTRICAL CHARACTERISTICS ($T_A = +25^\circ\text{C}$, unless otherwise noted)

Parameters / Test Conditions	Symbol	Min.	Max.	Unit
Drain-Source Breakdown Voltage $V_{GS} = 0\text{V}$, $I_D = 1\text{mA}$	$V_{(BR)DSS}$	100		Vdc
Gate-Source Voltage (Threshold) $V_{DS} \geq V_{GS}$, $I_D = 1.0\text{mA}$ $V_{DS} \geq V_{GS}$, $I_D = 1.0\text{mA}$, $T_j = +125^\circ\text{C}$ $V_{DS} \geq V_{GS}$, $I_D = 1.0\text{mA}$, $T_j = -55^\circ\text{C}$	$V_{GS(th)1}$ $V_{GS(th)2}$ $V_{GS(th)3}$	2.0 1.0	4.0 5.0	Vdc
Gate Current $V_{GS} = \pm 20\text{V}$, $V_{DS} = 0\text{V}$ $V_{GS} = \pm 20\text{V}$, $V_{DS} = 0\text{V}$, $T_j = +125^\circ\text{C}$	I_{GSS1} I_{GSS2}		± 100 ± 200	nAdc
Drain Current $V_{GS} = 0\text{V}$, $V_{DS} = 80\text{V}$ $V_{GS} = 0\text{V}$, $V_{DS} = 100\text{V}$, $T_j = +125^\circ\text{C}$ $V_{GS} = 0\text{V}$, $V_{DS} = 80\text{V}$, $T_j = +125^\circ\text{C}$	I_{DSS1} I_{DSS2} I_{DSS3}		25 1.0 0.25	μAdc mAdc mAdc
Static Drain-Source On-State Resistance $V_{GS} = 12\text{V}$, $I_D = 5.0\text{A}$ pulsed $V_{GS} = 12\text{V}$, $I_D = 8.0\text{A}$ pulsed $T_j = +125^\circ\text{C}$ $V_{GS} = 12\text{V}$, $I_D = 5.0\text{A}$ pulsed	$r_{DS(on)1}$ $r_{DS(on)2}$ $r_{DS(on)3}$		0.180 0.185 0.35	Ω Ω Ω
Diode Forward Voltage $V_{GS} = 0\text{V}$, $I_D = 8.0\text{A}$ pulsed	V_{SD}		1.5	Vdc

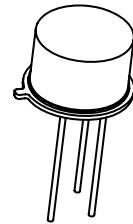

**TO-205AF
 (modified TO-39)
 JANSR2N7261, JANSF2N7261
 See Figure 1**

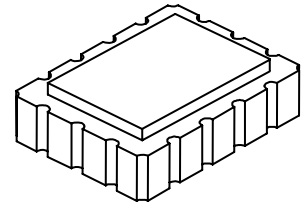

**18 PIN LEADLESS CHIP CARRIER
 JANSR2N7261U, JANSF2N7261U
 See Figure 2**

RADIATION HARDENED N-CHANNEL MOSFET

Reference MIL-PRF-19500/601

DYNAMIC CHARACTERISTICS

Parameters / Test Conditions	Symbol	Min.	Max.	Unit
Gate Charge: On-State Gate Charge Gate to Source Charge Gate to Drain Charge	$Q_{g(on)}$ Q_{gs} Q_{gd}		50 10 20	nC
		$V_{GS} = 12V, I_D = 8.0A$ $V_{DS} = 50V$		

SWITCHING CHARACTERISTICS

Parameters / Test Conditions	Symbol	Min.	Max.	Unit
Switching time tests: Turn-on delay time Rinse time Turn-off delay time Fall time	$t_{d(on)}$ t_r $t_{d(off)}$ t_f		25 32 40 40	ns
		$I_D = 8.0A, V_{GS} = 12Vdc,$ Gate drive impedance = 7.5Ω, $V_{DD} = 50Vdc$		
Diode Reverse Recovery Time	t_{rr}		270	ns
		$di/dt \leq 100A/\mu s, V_{DD} \leq 30V,$ $I_F = 8.0A$		

POST-IRRADIATION ELECTRICAL CHARACTERISTICS (3) ($T_A = +25^\circ C$, unless otherwise noted)

Parameters / Test Conditions	Symbol	Min.	Max.	Unit
Drain-Source Breakdown Voltage $V_{GS} = 0V, I_D = 1mA$	$V_{(BR)DSS}$	100		Vdc
Gate-Source Voltage (Threshold) $V_{DS} \geq V_{GS}, I_D = 1.0mA$ MSR $V_{DS} \geq V_{GS}, I_D = 1.0mA$ MSF	$V_{GS(th)1}$ $V_{GS(th)1}$	2.0 1.25	4.0 4.5	Vdc
Gate Current $V_{GS} = \pm 20V, V_{DS} = 0V$	I_{GSS1}		± 100	nAdc
Drain Current $V_{GS} = 0V, V_{DS} = 80V$ MSR $V_{GS} = 0V, V_{DS} = 80V$ MSF	I_{DSS1}		25 50	μ Adc
Static Drain-Source On-State Voltage $V_{GS} = 12V, I_D = 5.0A$ pulsed MSR $V_{GS} = 12V, I_D = 5.0A$ pulsed MSF	$V_{DS(on)}$		0.9 1.2	Vdc
Diode Forward Voltage $V_{GS} = 0V, I_D = 8.0A$ pulsed	V_{SD}		1.5	Vdc

NOTE:

- (3) Post-Irradiation Electrical Characteristics apply to devices subjected to Steady State Total Dose Irradiation testing in accordance with MIL-STD-750 Method 1019. Separate samples are tested for VGS bias (12V), and VDS bias (80V) conditions.

6 Lake Street, Lawrence, MA 01841
 1-800-446-1158 / (978) 620-2600 / Fax: (978) 689-0803
 Website: <http://www.microsemi.com>

RADIATION HARDENED N-CHANNEL MOSFET

Reference MIL-PRF-19500/601

Single Event Effect (SEE) Characteristics:

Heavy Ion testing of the 2N7261 device has been characterized at the Texas A&M cyclotron. The following SOA curve has been established using the elements, LET, range, and Total Energy conditions as shown:

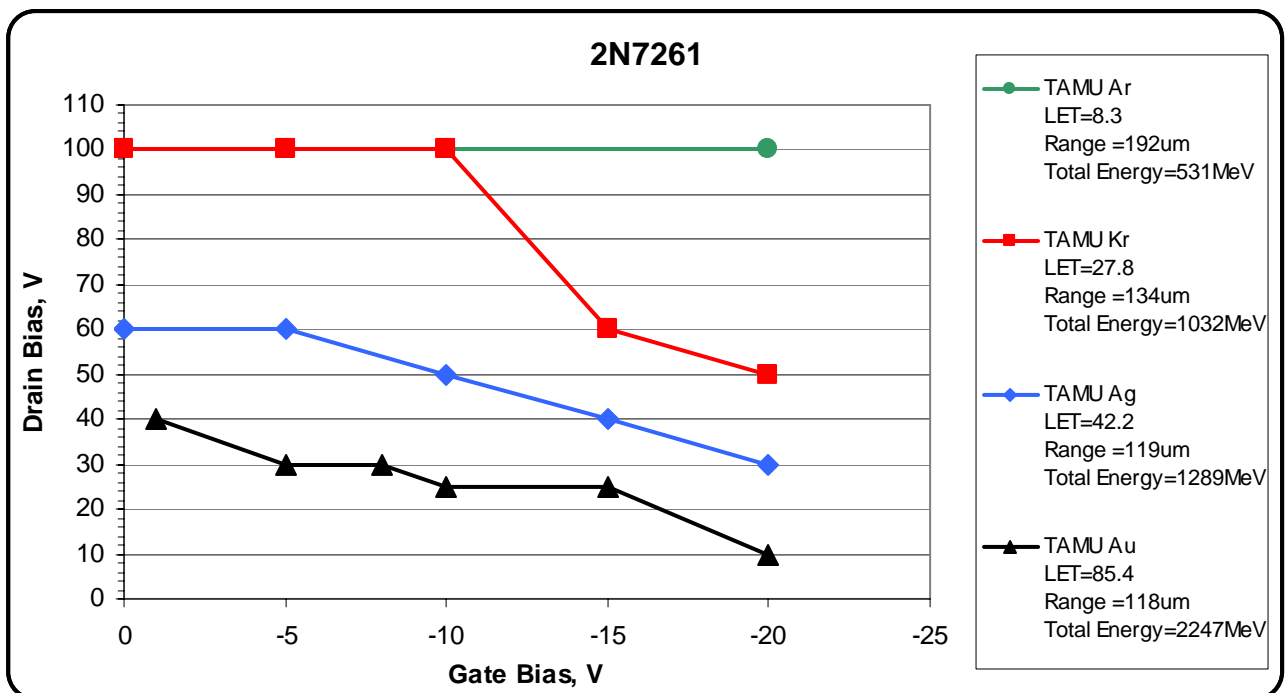

It should be noted that total energy levels are considered to be a factor in SEE characterization. Comparisons to other datasets should not be based on LET alone. Please consult factory for more information.

6 Lake Street, Lawrence, MA 01841
 1-800-446-1158 / (978) 620-2600 / Fax: (978) 689-0803
 Website: <http://www.microsemi.com>

RADIATION HARDENED N-CHANNEL MOSFET

Reference MIL-PRF-19500/601

Ltr	Dimensions			
	Inches		Millimeters	
	Min	Max	Min	Max
CD	.315	.355	8.00	9.01
CH	.160	.180	4.07	4.57
HD	.340	.370	8.64	9.40
LC	.200 BSC		5.08 BSC	
LD	.016	.021	0.41	0.53
LL	.500	.750	12.70	19.05
LU	.016	.019	0.41	0.48
L ₁		.050		1.27
L ₂	.250		6.35	
P	.070		1.78	
Q		.050		1.27
r		.010		0.25
TL	.029	.045	0.74	1.14
TW	.028	.034	0.71	0.86
α	45° BSC			
Term 1	Source			
Term 2	Gate			
Term 3	Drain			

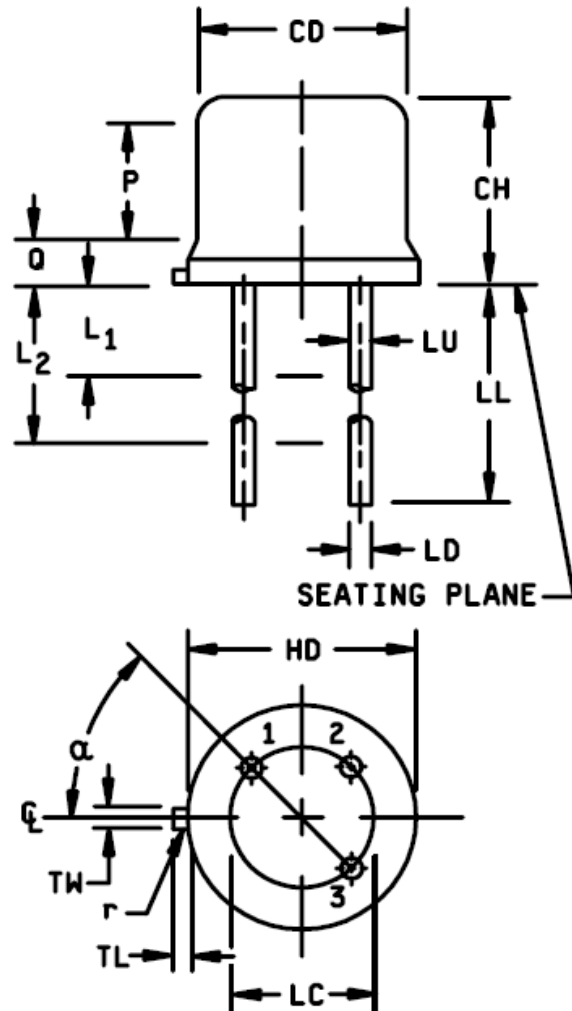

NOTES:

1. Dimensions are in inches.
2. Millimeters are given for general information only.
3. Lead number 1 is the source, lead number 2 is the gate, lead 3 is the drain and is electrically connected to the case, lead number 4 is omitted from this outline.
4. Dimensions and tolerancing shall be in accordance with ASME Y14.5M.

Figure 1: Case Outline and Pin Configuration for JANSR2N7261 & JANSF2N7261

6 Lake Street, Lawrence, MA 01841
 1-800-446-1158 / (978) 620-2600 / Fax: (978) 689-0803
 Website: <http://www.microsemi.com>

RADIATION HARDENED N-CHANNEL MOSFET

Reference MIL-PRF-19500/601

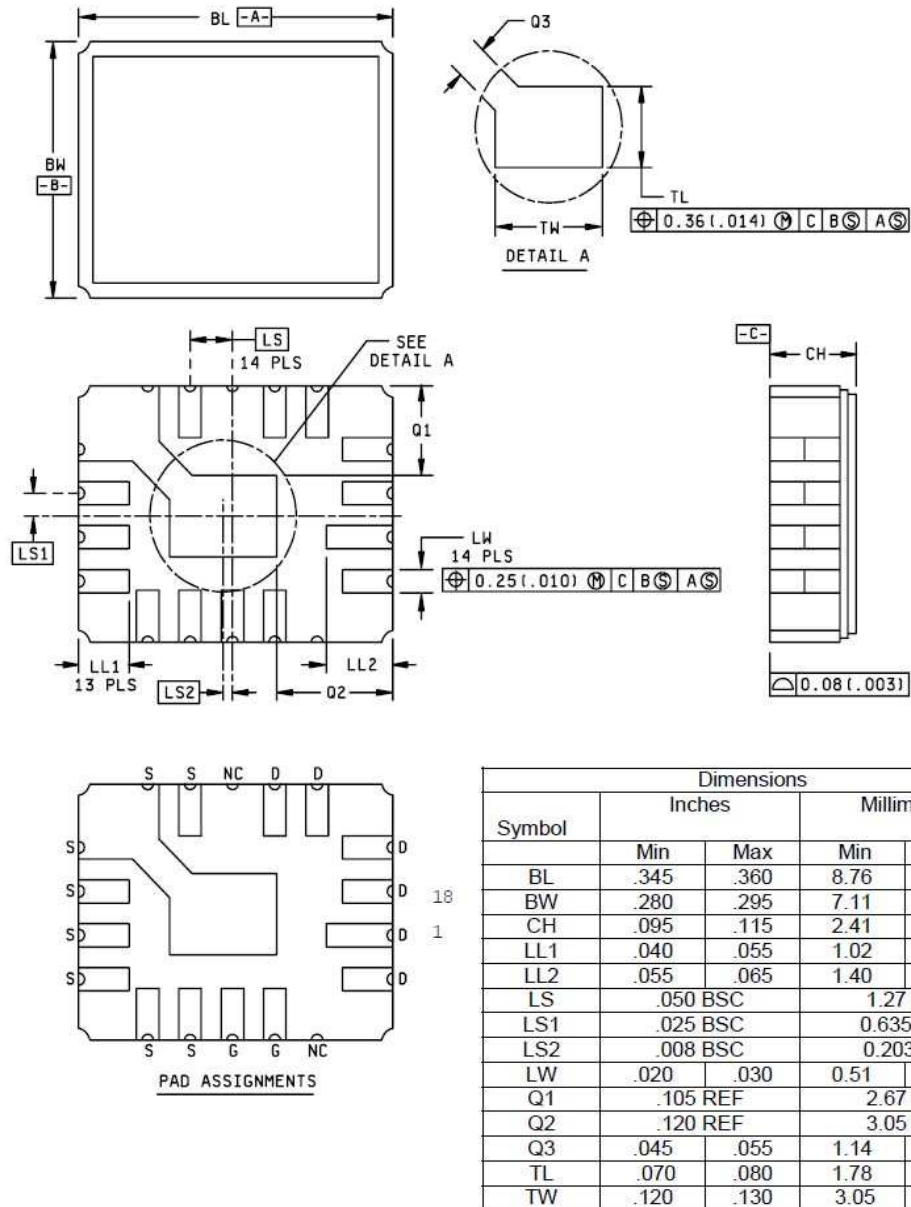

NOTES:

1. Dimensions are in inches.
2. Millimeters are given for general information only.
3. In accordance with ASME Y14.5M, diameters are equivalent to ϕ x symbology.

Figure 2: Case Outline and Pin Configuration for JANSR2N7261U & JANSF2N7261U