

RADIATION HARDENED NPN POWER SILICON SWITCHING TRANSISTOR

Qualified per MIL-PRF-19500/613

DEVICES

2N7373

LEVELS

- JANSM – 3K Rads (Si)
- JANSD – 10K Rads (Si)
- JANSP – 30K Rads (Si)
- JANSL – 50K Rads (Si)
- JANSR – 100K Rads (Si)
- JANSF – 300K Rads (Si)

ABSOLUTE MAXIMUM RATINGS ($T_C = +25^\circ\text{C}$ unless otherwise noted)

Parameters / Test Conditions	Symbol	Value	Unit	
Collector-Emitter Voltage	V_{CEO}	80	Vdc	
Collector-Base Voltage	V_{CBO}	100	Vdc	
Emitter-Base Voltage	V_{EBO}	5.0	Vdc	
Collector Current	I_C	5.0	A dc	
Total Power Dissipation	P_T	@ $T_A = +25^\circ\text{C}$ ⁽¹⁾	4.0	W
		@ $T_C = +25^\circ\text{C}$ ⁽²⁾	58	
Operating & Storage Junction Temperature Range	T_j, T_{stg}	-65 to +200	°C	
Thermal Resistance, Junction-to Case	$R_{\theta JC}$	3	°C/W	

- 1) Derate linearly 22.8mW/°C for $T_A > 25^\circ\text{C}$
- 2) Derate linearly 331mW/°C for $T_C > 25^\circ\text{C}$

ELECTRICAL CHARACTERISTICS ($T_A = +25^\circ\text{C}$, unless otherwise noted)

Parameters / Test Conditions	Symbol	Min.	Max.	Unit
OFF CHARACTERISTICS				
Collector-Emitter Breakdown Voltage $I_C = 100\text{mA dc}$	$V_{(BR)CEO}$	80		Vdc
Collector-Emitter Cutoff Current $V_{CE} = 60\text{Vdc}, V_{BE} = 0\text{Vdc}$ $V_{CE} = 100\text{Vdc}, V_{BE} = 0\text{Vdc}$	I_{CES1}		1.0	$\mu\text{A dc}$
	I_{CES2}		1.0	mA dc
Collector-Emitter Cutoff Current $V_{CE} = 40\text{Vdc}, I_B = 0$	I_{CEO}		50	$\mu\text{A dc}$
Emitter-Base Cutoff Current $V_{EB} = 4.0\text{Vdc}$ $V_{EB} = 5.5\text{Vdc}$	I_{EBO1}		1.0	$\mu\text{A dc}$
	I_{EBO2}		1.0	mA dc

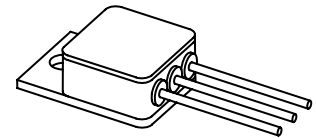

TO-254AA

**PIN 1 = BASE
 PIN 2 = COLLECTOR
 PIN 3 = EMITTER**

SEE FIGURE 1

RADIATION HARDENED NPN POWER SILICON SWITCHING TRANSISTOR

Qualified per MIL-PRF-19500/613

ELECTRICAL CHARACTERISTICS ($T_A = +25^\circ\text{C}$, unless otherwise noted) (CONT.)

Parameters / Test Conditions	Symbol	Min.	Max.	Unit
ON CHARACTERISTICS ⁽³⁾				
Forward-Current Transfer Ratio $I_C = 0.05\text{A dc}$, $V_{CE} = 5.0\text{V dc}$ $I_C = 2.5\text{A dc}$, $V_{CE} = 5.0\text{V dc}$ $I_C = 5.0\text{A dc}$, $V_{CE} = 5.0\text{V dc}$	h_{FE1} h_{FE2} h_{FE3}	50 70 40	--- 200 ---	
Base-Emitter Non-Saturated Voltage $V_{CE} = 5.0\text{V dc}$, $I_C = 2.5\text{A dc}$	V_{BE}		1.45	Vdc
Base-Emitter Saturation Voltage $I_C = 2.5\text{A dc}$, $I_B = 0.25\text{A dc}$ $I_C = 5.0\text{A dc}$, $I_B = 0.5\text{A dc}$	$V_{BE(sat)1}$ $V_{BE(sat)2}$		1.45 2.2	Vdc
Collector-Emitter Saturation Voltage $I_C = 2.5\text{A dc}$, $I_B = 0.25\text{A dc}$ $I_C = 5.0\text{A dc}$, $I_B = 0.5\text{A dc}$	$V_{CE(sat)1}$ $V_{CE(sat)2}$		0.75 1.5	Vdc

DYNAMIC CHARACTERISTICS

Parameters / Test Conditions	Symbol	Min.	Max.	Unit
Common Emitter Small Signal, Short Circuit Forward Current Transfer Ratio $V_{CE} = 5\text{V dc}$, $I_C = 100\text{mA dc}$, $f = 1\text{kHz}$	h_{fe}	50		
Magnitude of Common Emitter Small-Signal Short-Circuit Forward Current Transfer Ratio $I_C = 0.5\text{A dc}$, $V_{CE} = 5\text{V dc}$, $f = 10\text{MHz}$	$ h_{fe} $	7.0		
Output Capacitance $V_{CB} = 10\text{V dc}$, $I_E = 0$, $100\text{kHz} \leq f \leq 1.0\text{MHz}$	C_{obo}		250	pF

SAFE OPERATING AREA

DC Tests $T_C = +25^\circ\text{C}$, 1 Cycle, $t = 1\text{s}$ Test 1 $V_{CE} = 12\text{V dc}$, $I_C = 5.0\text{A dc}$ Test 2 $V_{CE} = 32\text{V dc}$, $I_C = 1.5\text{A dc}$ Test 3 $V_{CE} = 80\text{V dc}$, $I_C = 100\text{mA dc}$
--

(3) Pulse Test: Pulse Width = 300 μs , Duty Cycle $\leq 2.0\%$

RADIATION HARDENED NPN POWER SILICON SWITCHING TRANSISTOR

Qualified per MIL-PRF-19500/613

Ltr	Dimensions			
	Inches		Millimeters	
	Min	Max	Min	Max
BL	.535	.545	13.59	13.84
CH	.249	.260	6.32	6.60
LD	.035	.045	0.89	1.14
LL	.510	.570	12.95	14.48
LO	.150 BSC		3.81 BSC	
LS	.150 BSC		3.81 BSC	
MHD	.139	.149	3.53	3.78
MHO	.665	.685	16.89	17.40
TL	.790	.800	20.07	20.32
TT	.040	.050	1.02	1.27
TW	.535	.545	13.59	13.84
Term 1	Base			
Term 2	Collector			
Term 3	Emitter			

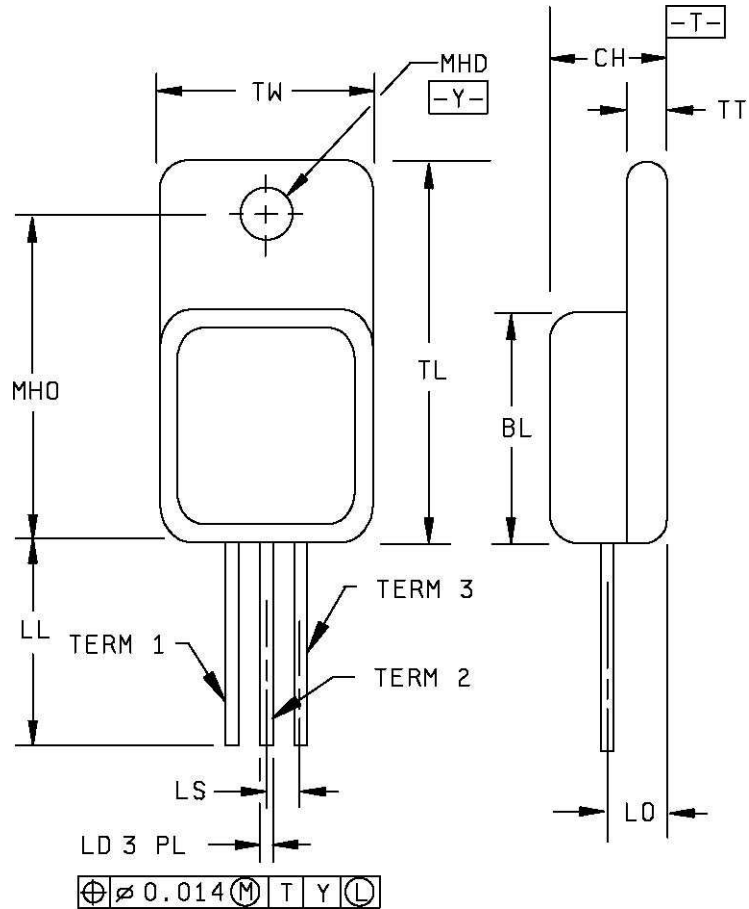

NOTES:

1. Dimensions are in inches.
- * 2. Millimeters are given for general information only.
3. All terminals are isolated from case.
4. In accordance with ASME Y14.5M, diameters are equivalent to ϕx symbology

FIGURE 1: PACKAGE DIMENSIONS