

## QUAD POWER FAULT MONITOR

### DESCRIPTION

The SG1548 is an integrated circuit capable of monitoring up to four positive DC supply voltages simultaneously for overvoltage and undervoltage fault conditions. An on-chip inverting op amp also allows monitoring one negative DC voltage. The fault tolerance window is accurately programmable from  $\pm 5\%$  to  $\pm 40\%$  using a simple divider network on the 2.5V reference. A single external capacitor sets the fault indication delay, eliminating false outputs due to switching noise, logic transition current spikes, and short-term AC line interruptions. An additional comparator referenced to 2.5V allows the AC line to be monitored for undervoltage conditions or for generation of a line clock. The comparator can also be used for programmable undervoltage lockout in a switching power supply. Uncommitted collector and emitter outputs permit both inverting and non-inverting operation. External availability of the precision 2.5V reference and open-collector logic outputs permit expansion to monitor additional voltage using available open-collector quad comparators.

### FEATURES

- Monitors four DC voltages and the AC line
- Precision 2.5V  $\pm 1\%$  low-drift reference
- Fault tolerance adjustable from  $\pm 5\%$  to  $\pm 40\%$
- $\pm 3\%$  trip threshold tolerance over temperature
- Separate 10mA, 40V overvoltage, undervoltage and AC line fault outputs
- Fault delay programmable with a single capacitor
- 30mV comparator hysteresis to prevent oscillations
- On-chip inverting op amp for negative voltage
- Open-collector output logic or expandability
- Operation from 4.5V to 40V supply

### HIGH RELIABILITY FEATURES - SG1548

- ◆ Available to MIL-STD-883
- ◆ Radiation data available
- ◆ LMI level "S" processing available

### BLOCK DIAGRAM

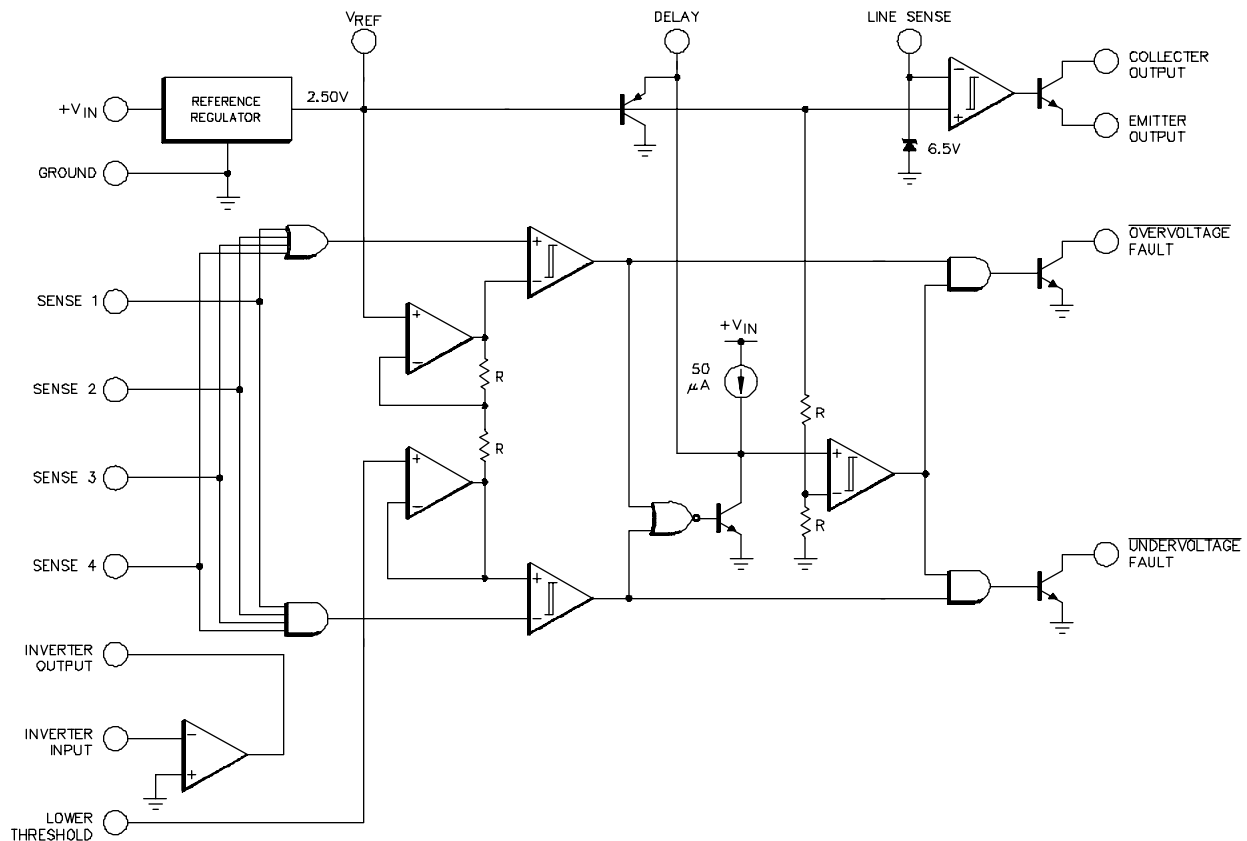

## ABSOLUTE MAXIMUM RATINGS (Note 1)

|  |               |
|--|---------------|
| Supply Voltage (+V <sub>IN</sub> ) ..... | 40V           |
| Fault Output Collector Voltage .....     | 40V           |
| Sense Input Voltage Range .....          | -0.3V to 6.0V |
| Fault Output Sink Current .....          | 20mA          |
| Line Sense Input Current .....           | ±1mA          |
| Inverting Op Amp Input Current .....     | -5mA          |

|                                       |                |
|---------------------------------------|----------------|
| Inverting Op Amp Output Current ..... | 25mA           |
| Operating Junction Temperature        |                |
| Hermetic (J, L Packages) .....        | 150°C          |
| Plastic (N, DW Packages) .....        | 150°C          |
| Storage Temperature Range .....       | -65°C to 150°C |
| Lead Temperature .....                | 300°C          |

Note 1. Values beyond which damage may occur.

Pb-free / RoHS Peak Package Solder Reflow Temp. (40 second max. exposure).. 260°C (+0, -5)

## THERMAL DATA

J Package:

|   |        |
|---|--------|
| Thermal Resistance-Junction to Case, $\theta_{JC}$ .....    | 30°C/W |
| Thermal Resistance-Junction to Ambient, $\theta_{JA}$ ..... | 80°C/W |

N Package:

|   |        |
|---|--------|
| Thermal Resistance-Junction to Case, $\theta_{JC}$ .....    | 40°C/W |
| Thermal Resistance-Junction to Ambient, $\theta_{JA}$ ..... | 65°C/W |

DW Package:

|   |        |
|---|--------|
| Thermal Resistance-Junction to Case, $\theta_{JC}$ .....    | 40°C/W |
| Thermal Resistance-Junction to Ambient, $\theta_{JA}$ ..... | 95°C/W |

L Package:

|   |         |
|---|---------|
| Thermal Resistance-Junction to Case, $\theta_{JC}$ .....    | 35°C/W  |
| Thermal Resistance-Junction to Ambient, $\theta_{JA}$ ..... | 120°C/W |

Note A. Junction Temperature Calculation:  $T_J = T_A + (P_D \times \theta_{JA})$ .

Note B. The above numbers for  $\theta_{JC}$  are maximums for the limiting thermal resistance of the package in a standard mounting configuration. The  $\theta_{JA}$  numbers are meant to be guidelines for the thermal performance of the device/pc-board system. All of the above assume no ambient airflow.

## RECOMMENDED OPERATING CONDITIONS (Note 2)

|  |               |
|--|---------------|
| Supply Voltage Range                     |               |
| ±25% Maximum Fault Window (Note 3) ..... | 4.5V to 35V   |
| ±40% Maximum Fault Window .....          | 5.0V to 35V   |
| Lower Threshold Input Range .....        | 1.5V to 2.45V |
| Fault Tolerance Window Range .....       | ±5% to ±40%   |
| Fault Output Sink Current Range .....    | 0 to 10mA     |

|  |                |
|--|----------------|
| Line Sense Output Current Range .....  | 0 to 10mA      |
| Voltage Reference Output Current ..... | 0 to 10mA      |
| Operating Ambient Temperature Range    |                |
| SG1548 .....                           | -55°C to 125°C |
| SG2548 .....                           | -25°C to 85°C  |
| SG3548 .....                           | 0°C to 70°C    |

Note 2. Range over which the device is functional.

Note 3. Limited by inverter amplifier positive swing at -55°C.

## ELECTRICAL CHARACTERISTICS

(Unless otherwise specified, these specifications apply over the operating ambient temperatures for SG1548 with  $-55^\circ\text{C} \leq T_A \leq 125^\circ\text{C}$ , SG2548 with  $-25^\circ\text{C} \leq T_A \leq 85^\circ\text{C}$ , SG3548 with  $0^\circ\text{C} \leq T_A \leq 70^\circ\text{C}$ , and  $+V_{IN} = 15\text{V}$ . Low duty cycle pulse testing techniques are used which maintains junction and case temperatures equal to the ambient temperature.)

| Parameter                             | Test Conditions                          | SG1548/2548 |       |       | SG3548 |       |       | Units |
|---------------------------------------|--|-------------|-------|-------|--------|-------|-------|-------|
|                                       |  | Min.        | Typ.  | Max.  | Min.   | Typ.  | Max.  |       |
| <b>Supply Section</b>                 |  |             |       |       |        |       |       |       |
| Supply Current                        | $+V_{IN} = 40\text{V}$                   |             | 4.8   | 10    |        | 4.8   | 10    | mA    |
| <b>Reference Section (Note 4)</b>     |  |             |       |       |        |       |       |       |
| Output Voltage                        | $T_J = 25^\circ\text{C}$                 | 2.475       | 2.500 | 2.525 | 2.475  | 2.500 | 2.525 | V     |
|                                       | Over Temperature                         | 2.450       |       | 2.550 | 2.450  |       | 2.550 | V     |
| Line Regulation                       | $+V_{IN} = 4.5\text{V to }35\text{V}$    |             | 1     | 5     |        | 1     | 5     | mV    |
| Load Regulation                       | $I_L = 0 \text{ to } 10\text{mA}$        |             | 3     | 10    |        | 3     | 10    | mV    |
| Short Circuit Current                 | $V_{REF} = 0\text{V}$                    | 10          | 25    | 50    | 10     | 25    | 50    | mA    |
| <b>Fault Window Generator Section</b> |  |             |       |       |        |       |       |       |
| Input Bias Current                    | $V_{PIN1} = 1.5\text{V to }2.45\text{V}$ |             | -0.4  | -2.0  |        | -0.4  | -2.0  | µA    |
| <b>DC Sense Inputs Section</b>        |  |             |       |       |        |       |       |       |
| Overvoltage Threshold                 | $V_{PIN1} = 0.95 \times V_{REF}$         | 2.547       | 2.625 | 2.704 | 2.547  | 2.625 | 2.704 | V     |
|                                       | $V_{PIN1} = 0.60 \times V_{REF}$         | 3.396       | 3.500 | 3.606 | 3.396  | 3.500 | 3.606 | V     |
| Undervoltage Threshold                | $V_{PIN1} = 0.95 \times V_{REF}$         | 2.304       | 2.375 | 2.447 | 2.304  | 2.375 | 2.447 | V     |
|                                       | $V_{PIN1} = 0.60 \times V_{REF}$         | 1.455       | 1.500 | 1.545 | 1.455  | 1.500 | 1.545 | V     |
| Input Bias Current                    | $V_{SENSE} = 1.5\text{V to }3.5\text{V}$ |             | ±0.6  | ±2.0  |        | ±0.6  | ±2.0  | µA    |
| Threshold Supply Rejection            | $+V_{IN} = 4.5\text{V to }35\text{V}$    | 60          | 100   |       | 60     | 100   |       | dB    |

Note 4.  $I_L = 0\text{mA}$

**ELECTRICAL CHARACTERISTICS** (continued)

| Parameter                                | Test Conditions                 | SG1548/2548 |       |       | SG3548 |       |       | Units   |
|--|---------------------------------|-------------|-------|-------|--------|-------|-------|---------|
|  |                                 | Min.        | Typ.  | Max.  | Min.   | Typ.  | Max.  |         |
| <b>Fault Delay Section</b>               |                                 |             |       |       |        |       |       |         |
| Comparator Threshold                     |                                 | 1.200       | 1.250 | 1.300 | 1.200  | 1.250 | 1.300 | V       |
| Comparator Hysteresis                    |                                 |             | 25    |       |        | 25    |       | mV      |
| Delay Charging Current                   | $V_{PIN8} = 0V$                 | 32.5        | 50    | 67.5  | 32.5   | 50    | 67.5  | $\mu A$ |
| On Saturation Voltage                    | $I_{PIN8} = 0mA$                |             | 0.1   | 0.2   |        | 0.1   | 0.2   | V       |
| OFF Clamp Voltage                        | $I_{PIN8} = 0mA$                |             | +3.2  | +3.6  |        | +3.2  | +3.6  | V       |
| <b>Inverting Op Amp Section</b> (Note 5) |                                 |             |       |       |        |       |       |         |
| Input Offset Voltage                     |                                 |             | 2     | 15    |        | 2     | 15    | mV      |
| Input Bias Current                       |                                 |             | -0.3  | -1.0  |        | -0.3  | -1.0  | $\mu A$ |
| Output High Voltage                      | $I_{SOURCE} = 5mA$              | 3.2         | 3.5   |       | 3.2    | 3.5   |       | V       |
| Output Low Voltage                       | $I_{SINK} = 5mA$                |             | 1.0   | 1.9   |        | 1.0   | 1.9   | V       |
| Large Signal Voltage Gain                | $R_L = 10K$                     | 72          | 100   |       | 72     | 100   |       | dB      |
| Output Source Current                    |                                 | 5           | 15    | 25    | 5      | 15    | 25    | mA      |
| Power Supply Rejection Ratio             | $+V_{IN} = 4.5V$ to 35V         | 72          | 100   |       | 72     | 100   |       | dB      |
| <b>AC Line Sense Section</b>             |                                 |             |       |       |        |       |       |         |
| Comparator Threshold                     | $V_{PIN5} = \text{Low to High}$ | 2.440       | 2.500 | 2.560 | 2.440  | 2.500 | 2.560 | V       |
| Comparator Hysteresis                    |                                 |             | 25    |       |        | 25    |       | mV      |
| Input Bias Current                       | $V_{PIN5} = 2.5V$               |             | 1     | 2     |        | 1     | 2     | $\mu A$ |
| Collector Leakage Current                | $V_{CE} = 40V$                  |             | 1     | 10    |        | 1     | 10    | $\mu A$ |
| Collector Saturation Voltage             | $I_C = 10mA$                    |             | 0.2   | 0.5   |        | 0.2   | 0.5   | V       |
| Emitter Output Voltage                   | $I_E = 10mA$                    | 12          | 13    |       | 12     | 13    |       | V       |
| Diode Clamp Voltage                      | $I_{PIN5} = 1mA$                | 6.0         |       | 7.5   | 6.0    |       | 7.5   | V       |
|  | $I_{PIN5} = -1mA$               | -0.3        |       | -1.0  | -0.3   |       | -1.0  | V       |
| <b>Fault Logic Outputs (Each output)</b> |                                 |             |       |       |        |       |       |         |
| Collector Leakage Current                | $V_C = 40V$                     |             | 1     | 10    |        | 1     | 10    | $\mu A$ |
| Collector Saturation Voltage             | $I_C = 10mA$                    |             | 0.2   | 0.5   |        | 0.2   | 0.5   | V       |

Note 5.  $+V_{IN} = 4.5V$ .

**APPLICATION INFORMATION**

**SETTING THE FAULT TOLERANCE WINDOW**

The fault tolerance window is set by applying a voltage less than the +2.50V reference to the Lower Threshold input (Pin 1). The voltage is obtained by a resistor divider from the reference (Pin 3) to ground. If  $\pm 5\%$  tolerance is desired, then 95% of the reference (+2.375V) is applied to Pin 1. If  $\pm 40\%$  is wanted, then 60% of the reference (+1.50V) is applied. In the example on the back page, the tolerance is  $\pm 5\%$ . The nominal overvoltage and undervoltage thresholds are centered about the reference at +2.625V and +2.375V (+2.500V  $\pm 0.125V$ ).

**SCALING THE MONITORED SUPPLY VOLTAGES**

Each positive voltage to be monitored is divided down to +2.50V with a resistor network and connected to one of the Sense inputs. Unused Sense inputs should be connected to the reference. This will not increase the bias current. A variation of the monitored voltages out of the programmed tolerance range will cause the appropriate overvoltage or undervoltage fault output to switch LOW. The effective tolerance on any input may be broadened with an additional resistor to the voltage reference. The example on the back page shows a  $\pm 10\%$  tolerance on the +5V supply although the SG1548 is programmed for a  $\pm 5\%$  tolerance. The procedure for calculating the resistor value is found in the SG1548 Application Note.

**MONITORING A NEGATIVE VOLTAGE**

A negative voltage can be converted to a positive one and simultaneously scaled to +2.50V by using the internal operational amplifier as an inverter. Only an input resistor and feedback resistor are required.

**SETTING THE FAULT DELAY**

A single capacitor at the Delay pin sets the time an out-of-tolerance fault must persist before a fault is actually declared. This feature allows switching noise on the supplies to be rejected. The delay time is given by: Delay = 25ms/ $\mu F$ .

**AC LINE MONITORING**

The AC line voltage can be monitored for single-cycle dropouts with the few components shown in the example. A half-wave rectifier charges the capacitor on positive line cycles. After the positive peak and during the negative line cycle the capacitor discharges from a fixed voltage controlled by the internal Zener diode. If a positive cycle is missing, the capacitor discharges to below the +2.5V trip point of the comparator, causing the output transistor to turn on.

## APPLICATION EXAMPLE

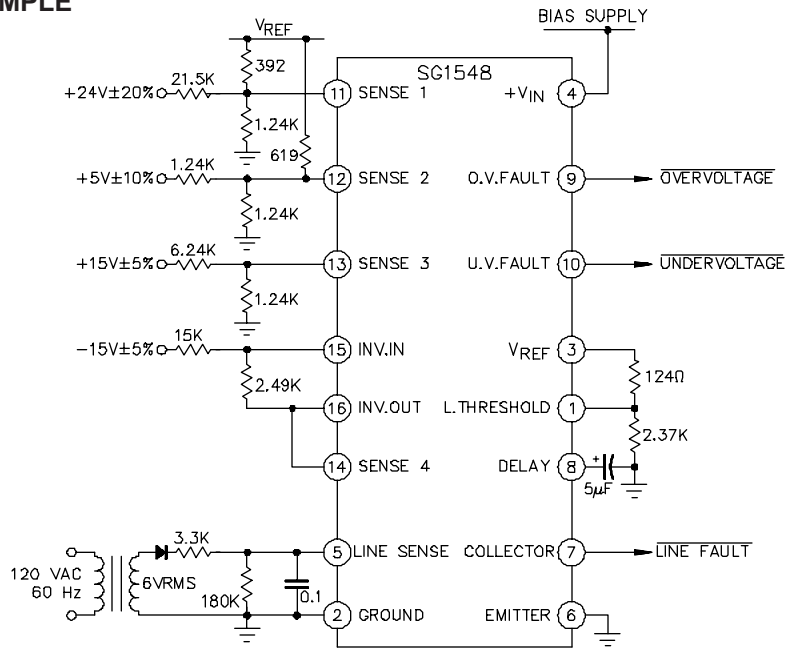

In this example, the SG1548 simultaneously monitors four DC voltages: +5V, +24V, and ±15V. Three different fault tolerances are programmed: ±5% on the two 15V supplies, ±10% on the +5V supply, and ±20% on the +24V supply. The 5μF delay capacitor provides 125 milliseconds of fault delay.

## CONNECTION DIAGRAMS & ORDERING INFORMATION (See Notes Below)

| Package   | Part No.                                      | Ambient Temperature Range  | Connection Diagram  |
|---|---|--|---|
| 16-PIN CERAMIC DIP<br>J - PACKAGE   | SG1548J/883B<br>SG1548J<br>SG2548J<br>SG3548J | -55°C to 125°C<br>-55°C to 125°C<br>-25°C to 85°C<br>0°C to 70°C | <p>LOWER THRESHOLD □ 1 □ 16 □ INV. OUTPUT<br/>GROUND □ 2 □ 15 □ INV. INPUT<br/>V<sub>REF</sub> □ 3 □ 14 □ SENSE 4<br/>+V<sub>IN</sub> □ 4 □ 13 □ SENSE 3<br/>LINE SENSE □ 5 □ 12 □ SENSE 2<br/>EMITTER OUTPUT □ 6 □ 11 □ SENSE 1<br/>COLLECTOR OUTPUT □ 7 □ 10 □ U.V. FAULT<br/>DELAY □ 8 □ 9 □ O.V. FAULT</p> <p>N package: Pb-free / RoHS 100% Matte Tin Lead Finish</p>  |
| 16-PIN PLASTIC DIP<br>N - PACKAGE<br>Pb- free / RoHS Transition DC: 0503* | SG2548N<br>SG3548N                            | -25°C to 85°C<br>0°C to 70°C                                     | <p>LOWER THRESHOLD □ 1 □ 16 □ INV. OUTPUT<br/>GROUND □ 2 □ 15 □ INV. INPUT<br/>V<sub>REF</sub> □ 3 □ 14 □ SENSE 4<br/>+V<sub>IN</sub> □ 4 □ 13 □ SENSE 3<br/>LINE SENSE □ 5 □ 12 □ SENSE 2<br/>EMITTER OUTPUT □ 6 □ 11 □ SENSE 1<br/>COLLECTOR OUTPUT □ 7 □ 10 □ U.V. FAULT<br/>DELAY □ 8 □ 9 □ O.V. FAULT</p> <p>N package: Pb-free / RoHS 100% Matte Tin Lead Finish</p>  |
| 16-PIN WIDE BODY<br>PLASTIC S.O.I.C.<br>DW - PACKAGE                      | SG2548DW<br>SG3548DW                          | -25°C to 85°C<br>0°C to 70°C                                     | <p>LOWER THRESHOLD □ 1 □ 16 □ INV. OUTPUT<br/>GROUND □ 2 □ 15 □ INV. INPUT<br/>V<sub>REF</sub> □ 3 □ 14 □ SENSE 4<br/>+V<sub>IN</sub> □ 4 □ 13 □ SENSE 3<br/>LINE SENSE □ 5 □ 12 □ SENSE 2<br/>EMITTER OUTPUT □ 6 □ 11 □ SENSE 1<br/>COLLECTOR OUTPUT □ 7 □ 10 □ U.V. FAULT<br/>DELAY □ 8 □ 9 □ O.V. FAULT</p> <p>DW package: Pb-free / RoHS 100% Matte Tin Lead Finish</p> |
| 20-PIN CERAMIC (LCC)<br>LEADLESS CHIP CARRIER<br>L - PACKAGE              | SG1548L/883B<br>SG1548L                       | -55°C to 125°C<br>-55°C to 125°C                                 | <p>1. N.C.<br/>2. LOWER THRESHOLD<br/>3. GROUND<br/>4. V<sub>REF</sub><br/>5. +V<sub>IN</sub><br/>6. N.C.<br/>7. LINE SENSE<br/>8. EMITTER OUTPUT<br/>9. COLLECTOR OUTPUT<br/>10. DELAY<br/>11. N.C.<br/>12. O.V. FAULT<br/>13. U.V. FAULT<br/>14. SENSE 1<br/>15. SENSE 2<br/>16. N.C.<br/>17. SENSE 3<br/>18. SENSE 4<br/>19. INV. INPUT<br/>20. INV. OUTPUT</p>          |

Note 1. Contact factory for JAN and DESC product availability.  
2. All parts are viewed from the top.

\*RoHS Compliant