

Accessories

Mounting accessories

Z 119.082



Features

- For high-dynamic applications and high demand on accuracy

Description

Fix spring coupling onto flange by help of the attached screws. Push encoder onto the drive shaft and mount Spring coupling onto the contact surface.

Part number

Z 119.082 Spring coupling for encoders with $\varnothing 58$ mm housing, hole distance 63 mm

Scope of delivery

Included: spring coupling, six screws M3 x 6 with six lock washers

Suitable for

G0A2H, G0AMH, G0L2H, G0LMH, G0M2H, G0MMH, G0P5H, GBA2H, GBA2S, GBAMH, GBAMS, GBMMH, GBMMS, GBP5H, GEMMH, GXA2S, GXAMS, GXL2S, GXLMS, GXM2S, GXM7S, GXMMS, GXP5S

Dimensions

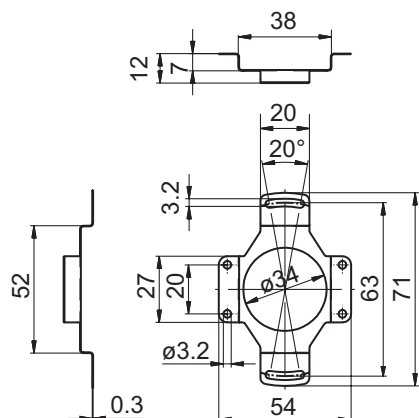

Dimension

