

Accessories

Mounting accessories

Z 119.068



Features

- Quick, secure and easy mounting
- To be mounted on the motor's fan guard

Description

Fix spring coupling onto flange by help of the attached screws. Push encoder onto the drive shaft and mount Spring coupling onto the contact surface.

Part number

Z 119.068 Spring coupling

Scope of delivery

Included: spring coupling, two screws M3 x 6 with two lock washers

Suitable for

GI341, GI342

Dimensions

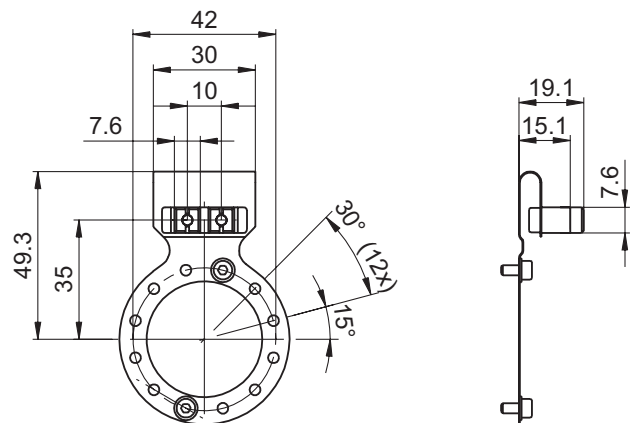

Dimension

