

NPN POWER SILICON SWITCHING TRANSISTOR

Qualified per MIL-PRF-19500/560

DEVICES

2N5339 2N5339U3

LEVELS
JAN
JANTX
JANTXV
JANS

ABSOLUTE MAXIMUM RATINGS ($T_C = +25^\circ\text{C}$ unless otherwise noted)

Parameters / Test Conditions	Symbol	Value	Unit
Collector-Emitter Voltage	V_{CEO}	100	Vdc
Collector-Base Voltage	V_{CBO}	100	Vdc
Emitter-Base Voltage	V_{EBO}	6.0	Vdc
Base Current	I_B	1.0	Adc
Collector Current	I_C	5.0	Adc
Total Power Dissipation	P_T	@ $T_A = +25^\circ\text{C}$ ⁽¹⁾	1.0
		@ $T_C = +25^\circ\text{C}$ ⁽²⁾	17.5
		@ $T_C = +25^\circ\text{C}$ ⁽³⁾ – U3	75
Operating & Storage Junction Temperature Range	T_{op}, T_{stg}	-65 to +200	$^\circ\text{C}$
Thermal Resistance, Junction-to Air	$R_{\theta JA}$	175	$^\circ\text{C/W}$

NOTES:

- 1) Derate linearly 5.71mW/ $^\circ\text{C}$ for $T_A > 25^\circ\text{C}$
- 2) Derate linearly 100mW/ $^\circ\text{C}$ for $T_C > 25^\circ\text{C}$
- 3) Derate linearly 434mW/ $^\circ\text{C}$ for $T_C > 25^\circ\text{C} - \text{U3}$

ELECTRICAL CHARACTERISTICS ($T_A = +25^\circ\text{C}$, unless otherwise noted)

Parameters / Test Conditions	Symbol	Min.	Max.	Unit
OFF CHARACTERISTICS				
Collector-Emitter Breakdown Voltage $I_C = 50\text{mAdc}$	$V_{(BR)CEO}$	100		Vdc
Collector-Emitter Cutoff Current $V_{CE} = 100\text{Vdc}$	I_{CEO}		100	μAdc
Collector-Emitter Cutoff Current $V_{CE} = 90\text{Vdc}, V_{BE} = 1.5\text{Vdc}$	I_{CEX}		1.0	μAdc
Collector-Base Cutoff Current $V_{CB} = 100\text{Vdc}$	I_{CBO}		1.0	μAdc
Emitter-Base Cutoff Current $V_{EB} = 6.0\text{Vdc}$	I_{EBO}		100	μAdc

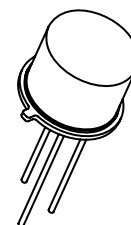

TO-39
(TO-205AD)

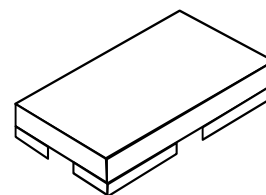

U-3
(TO-276AA)

ELECTRICAL CHARACTERISTICS ($T_A = +25^\circ\text{C}$, unless otherwise noted) (CONT.)

Parameters / Test Conditions	Symbol	Min.	Max.	Unit
ON CHARACTERISTICS ⁽³⁾				
Forward-Current Transfer Ratio $I_C = 0.5\text{A}_{dc}$, $V_{CE} = 2.0\text{V}_{dc}$ $I_C = 2.0\text{A}_{dc}$, $V_{CE} = 2.0\text{V}_{dc}$ $I_C = 5.0\text{A}_{dc}$, $V_{CE} = 2.0\text{V}_{dc}$	h_{FE}	60 60 40	240	
Collector-Emitter Saturation Voltage $I_C = 2.0\text{A}_{dc}$, $I_B = 0.2\text{A}_{dc}$ $I_C = 5.0\text{A}_{dc}$, $I_B = 0.5\text{A}_{dc}$	$V_{CE(sat)}$		0.7 1.2	Vdc
Base-Emitter Saturation Voltage $I_C = 2.0\text{A}_{dc}$, $I_B = 0.2\text{A}_{dc}$ $I_C = 5.0\text{A}_{dc}$, $I_B = 0.5\text{A}_{dc}$	$V_{BE(sat)}$		1.2 1.8	Vdc

DYNAMIC CHARACTERISTICS

Parameters / Test Conditions	Symbol	Min.	Max.	Unit
Magnitude of Common Emitter Small-Signal Short-Circuit Forward Current Transfer Ratio $I_C = 0.5\text{A}_{dc}$, $V_{CE} = 10\text{V}_{dc}$, $f = 10\text{MHz}$	$ h_{fe} $	3.0	15	
Output Capacitance $V_{CB} = 10\text{V}_{dc}$, $I_E = 0$, $100\text{kHz} \leq f \leq 1.0\text{MHz}$	C_{obo}		250	pF
Input Capacitance $V_{BE} = 2.0\text{V}_{dc}$, $I_C = 0$, $100\text{kHz} \leq f \leq 1.0\text{MHz}$	C_{ibo}		1,000	pF

SAFE OPERATING AREA

DC Tests $T_C = +25^\circ\text{C}$, 1 Cycle, $t \geq 0.5\text{s}$ Test 1 $V_{CE} = 2.0\text{V}_{dc}$, $I_C = 5.0\text{A}_{dc}$ Test 2 $V_{CE} = 5.0\text{V}_{dc}$, $I_C = 2.0\text{A}_{dc}$ Test 3 $V_{CE} = 90\text{V}_{dc}$, $I_C = 55\text{mA}_{dc}$
--

(3) Pulse Test: Pulse Width = 300 μs , Duty Cycle $\leq 2.0\%$

PACKAGE DIMENSIONS

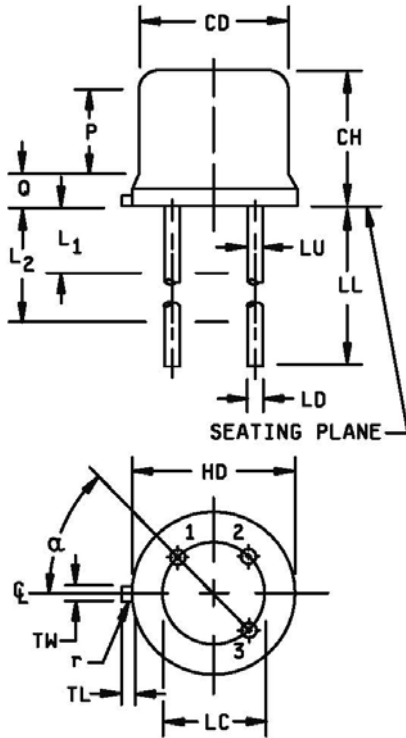

Symbol	Dimensions				Note
	Inches		Millimeters		
	Min	Max	Min	Max	
CD	.305	.355	7.75	9.02	5
CH	.240	.260	6.10	6.60	
HD	.335	.370	8.51	9.40	3
LC	.200 TP		5.08 TP		6
LD	.016	.021	0.41	0.53	7
LL	.500	.750	12.70	19.05	7
LU	.016	.019	0.41	0.48	7
L ₁		.050		1.27	7
L ₂	.250		6.35		7
TL	.029	.045	0.74	1.14	3
TW	.028	.034	0.71	0.86	10
P	.100		2.54		5
Q		.050		1.27	4
r		.010		0.25	10, 11
α	45° TP		45° TP		6
Notes	1, 2, 8, 9		1, 2, 8, 9		

NOTES:

- Dimensions are in inches.
- Millimeters are given for general information only.
- Symbol TL is measured from HD maximum.
- Details of outline in this zone are optional.
- Symbol CD shall not vary more than .010 (0.25 mm) in zone P. This zone is controlled for automatic handling.
- Leads at gauge plane .054 inch (1.37 mm) +.001 inch (0.03 mm) -.000 inch (0.00 mm) below seating plane shall be within .007 inch (0.18 mm) radius of true position (TP) relative to tab. Device may be measured by direct methods or by gauge.
- Symbol LD applies between L₁ and L₂. Dimension LD applies between L₂ and LL minimum.
- Lead designation, depending on device type, shall be as follows:

Lead number	TO-39
1	Emitter
2	Base
3	Collector

- Lead number three is electrically connected to case.
- Beyond r maximum, TW shall be held for a minimum length of .011 inch (0.28 mm).
- Symbol r applied to both inside corners of tab.
- In accordance with ASME Y14.5M, diameters are equivalent to ϕx symbology.

FIGURE 1. Physical dimensions (TO-39)

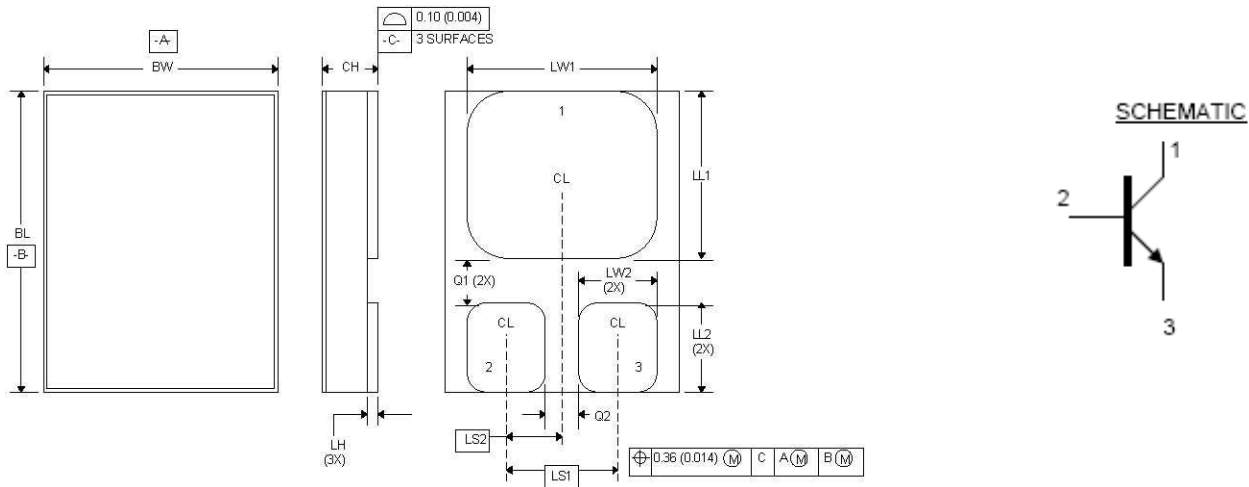

NOTES:

1. Dimensions are in inches.
2. Millimeters are given for general information only.
3. In accordance with ASME Y14.5M, diameters are equivalent to ϕx symbology.
4. Terminal 1 - collector, terminal 2 - base, terminal 3 - emitter.

Ltr	Dimensions			
	Inches		Millimeters	
	Min	Max	Min	Max
BL	.395	.405	10.03	10.29
BW	.291	.301	7.40	7.65
CH	.1085	.1205	2.76	3.06
LH	.010	.020	0.25	0.51
LW ₁	.281	.291	7.14	7.39
LW ₂	.090	.100	2.29	2.54
LL ₁	.220	.230	5.59	5.84
LL ₂	.115	.125	2.92	3.18
LS ₁	.150 BSC		3.81 BSC	
LS ₂	.075 BSC		1.91 BSC	
Q ₁	.030		0.762	
Q ₂	.030		0.762	

FIGURE 2. Physical dimensions and configuration (U3) (SMD 5) (TO-276AA)