

N-CHANNEL MOSFET
Qualified per MIL-PRF-19500/557

DEVICES

2N6798 2N6798U

LEVELS

**JAN
 JANTX
 JANTXV**

ABSOLUTE MAXIMUM RATINGS ($T_C = +25^\circ\text{C}$ unless otherwise noted)

Parameters / Test Conditions	Symbol	Value	Unit
Drain – Source Voltage	V_{DS}	200	Vdc
Gate – Source Voltage	V_{GS}	± 20	Vdc
Continuous Drain Current $T_C = +25^\circ\text{C}$	I_{D1}	5.5	A _{dc}
Continuous Drain Current $T_C = +100^\circ\text{C}$	I_{D2}	3.5	A _{dc}
Max. Power Dissipation	P_{tl}	25 ⁽¹⁾	W
Drain to Source On State Resistance	$R_{ds(on)}$	0.4 ⁽²⁾	Ω
Operating & Storage Temperature	T_{op}, T_{stg}	-55 to +150	$^\circ\text{C}$

Note: (1) Derated Linearly by 0.2 W/ $^\circ\text{C}$ for $T_C > +25^\circ\text{C}$
 (2) $V_{GS} = 10\text{Vdc}$, $I_D = 3.5\text{A}$

ELECTRICAL CHARACTERISTICS ($T_A = +25^\circ\text{C}$, unless otherwise noted)

Parameters / Test Conditions	Symbol	Min.	Max.	Unit
Drain-Source Breakdown Voltage $V_{GS} = 0\text{V}$, $I_D = 1\text{mA}$	$V_{(BR)DSS}$	200		Vdc
Gate-Source Voltage (Threshold) $V_{DS} \geq V_{GS}$, $I_D = 0.25\text{mA}$ $V_{DS} \geq V_{GS}$, $I_D = 0.25\text{mA}$, $T_j = +125^\circ\text{C}$ $V_{DS} \geq V_{GS}$, $I_D = 0.25\text{mA}$, $T_j = -55^\circ\text{C}$	$V_{GS(th)1}$ $V_{GS(th)2}$ $V_{GS(th)3}$	2.0 1.0	4.0 5.0	Vdc
Gate Current $V_{GS} = \pm 20\text{V}$, $V_{DS} = 0\text{V}$ $V_{GS} = \pm 20\text{V}$, $V_{DS} = 0\text{V}$, $T_j = +125^\circ\text{C}$	I_{GSS1} I_{GSS2}		± 100 ± 200	nA _{dc}
Drain Current $V_{GS} = 0\text{V}$, $V_{DS} = 160\text{V}$ $V_{GS} = 0\text{V}$, $V_{DS} = 160\text{V}$, $T_j = +125^\circ\text{C}$	I_{DSS1} I_{DSS2}		25 0.25	μA _{dc} mA _{dc}
Static Drain-Source On-State Resistance $V_{GS} = 10\text{V}$, $I_D = 3.5\text{A}$ pulsed $V_{GS} = 10\text{V}$, $I_D = 5.5\text{A}$ pulsed $T_j = +125^\circ\text{C}$ $V_{GS} = 10\text{V}$, $I_D = 3.5\text{A}$ pulsed	$r_{DS(on)1}$ $r_{DS(on)2}$ $r_{DS(on)3}$		0.4 0.42 0.75	Ω Ω Ω
Diode Forward Voltage $V_{GS} = 0\text{V}$, $I_D = 5.5\text{A}$ pulsed	V_{SD}		1.4	Vdc

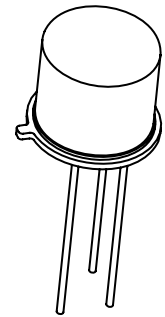

TO-205AF
 (formerly TO-39)

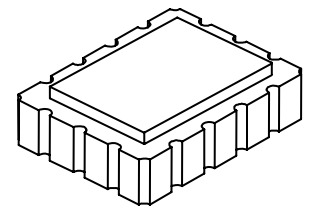

U – 18 LCC

N-CHANNEL MOSFET
Qualified per MIL-PRF-19500/557

DYNAMIC CHARACTERISTICS

Parameters / Test Conditions	Symbol	Min.	Max.	Unit
Gate Charge:				
On-State Gate Charge	$Q_{g(on)}$		42.07	nC
Gate to Source Charge	Q_{gs}		5.29	
Gate to Drain Charge	Q_{gd}		28.11	

$V_{GS} = 10V, I_D = 5.5A$
 $V_{DS} = 100V$

SWITCHING CHARACTERISTICS

Parameters / Test Conditions	Symbol	Min.	Max.	Unit
Switching time tests:				
Turn-on delay time	$t_{d(on)}$		30	ns
Rinse time	t_r		50	
Turn-off delay time	$t_{d(off)}$		50	
Fall time	t_f		40	
Diode Reverse Recovery Time	t_{rr}		500	ns

$I_D = 5.5A, V_{GS} = 10Vdc,$
 Gate drive impedance = $7.5\Omega,$
 $V_{DD} = 77Vdc$

$di/dt \leq 100A/\mu s, V_{DD} \leq 50V,$
 $I_F = 5.5A$

N-CHANNEL MOSFET
 Qualified per MIL-PRF-19500/557

PACKAGE DIMENSIONS

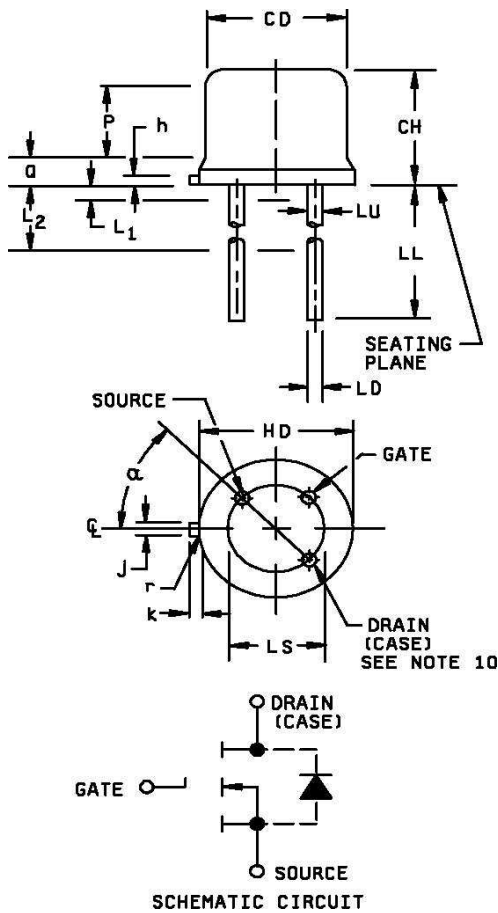

Ltr	Dimensions				Notes
	Inches		Millimeters		
	Min	Max	Min	Max	
CD	.305	.355	7.75	9.02	
CH	.160	.180	4.07	4.57	
HD	.335	.370	8.51	9.39	
h	.009	.041	0.23	1.04	
J	.028	.034	0.72	0.86	2
k	.029	.045	0.74	1.14	3
LD	.016	.021	0.41	0.53	7, 8
LL	.500	.750	12.7	19.05	7, 8
LS	.200 TP		5.08 TP		6
LU	.016	.019	0.41	0.48	7, 8
L1		.050		1.27	7, 8
L2	.250		6.35		7, 8
P	.070		1.78		5
Q		.050		1.27	4
r		.010		0.25	9
α	45° TP		45° TP		6

NOTES:

- 1 Dimensions are in inches. Millimeters are given for general information only.
- 2 Beyond radius (r) maximum, j shall be held for a minimum length of .011 (0.028 mm).
- 3 Dimension k measured from maximum HD.
- 4 Outline in this zone is not controlled.
- 5 Dimension CD shall not vary more than .010 (0.25 mm) in zone P. This zone is controlled for automatic handling.
- 6 Leads at gauge plane .054 +.001, -.000 (1.37 +0.03, -0.00 mm) below seating plane shall be within .007 (0.18 mm) radius of true position (TP) at maximum material condition (MMC) relative to tab at MMC.
- 7 All three leads.
- 8 Radius (r) applies to both inside corners of tab.
- 9 Drain is electrically connected to the case.
- 10 In accordance with ASME Y14.5M, diameters are equivalent to φx symbology.

* **FIGURE 1. Physical dimensions for TO-205AF.**

N-CHANNEL MOSFET

Qualified per MIL-PRF-19500/557

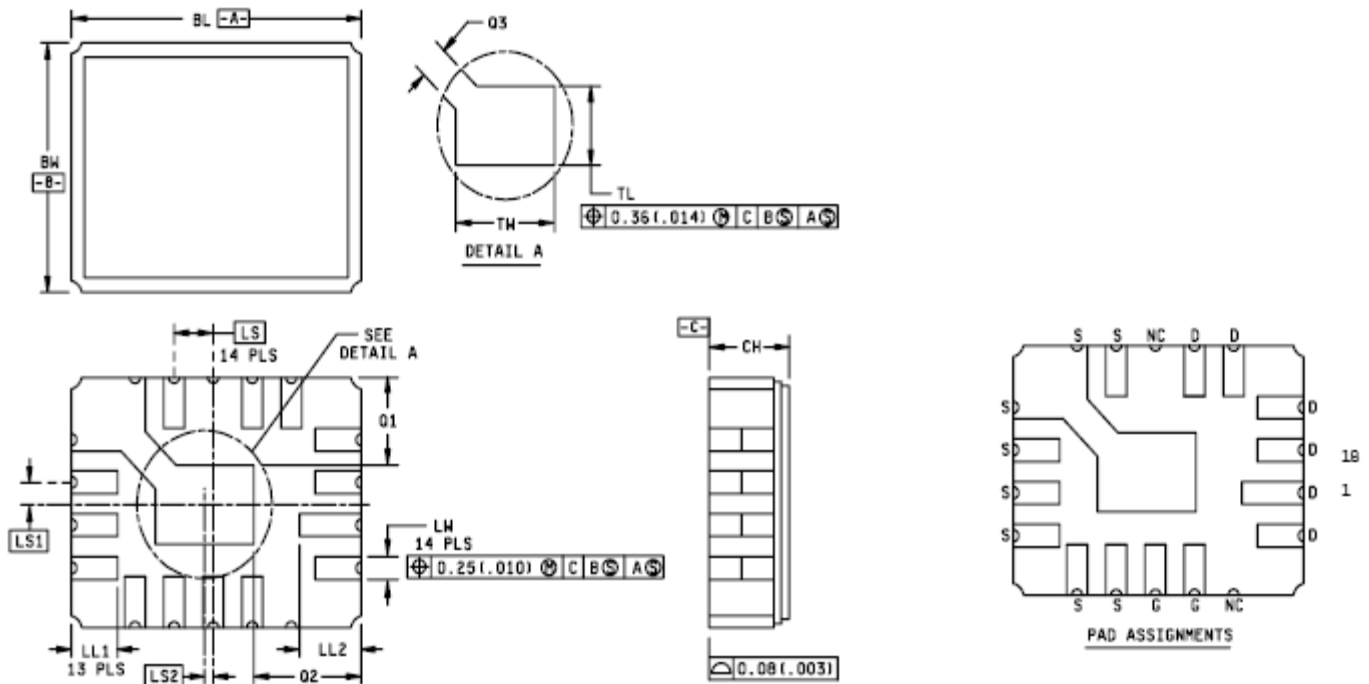

NOTES:

- 1 Dimensions are in inches.
- 2 Millimeters are given for general information only.
- 3 In accordance with ASME Y14.5M, diameters are equivalent to ϕ x symbology.
- 4 Ceramic package only.

Ltr	Dimensions			
	Inches		Millimeters	
	Min	Max	Min	Max
BL	.345	.360	8.77	
BW	.280	.295	7.11	
CH	.095	.115	2.41	
LL1	.040	.055	1.02	
LL2	.055	.065	1.40	
LS	.050 BSC		1.27 BSC	
LS1	.025 BSC		0.635 BSC	
LS2	.008 BSC		0.203 BSC	
LW	.020	.030	0.51	0.76
Q1	.105 REF		2.67 REF	
Q2	.120 REF		3.05 REF	
Q3	.045	.055	1.14	1.40
TL	.070	.080	1.78	2.03
TW	.120	.130	3.05	3.30

* **FIGURE 2. Physical dimensions for LCC.**